



- **Significant increase in Rx efficiency and Tx radiation compared to a whip antenna for NVIS operations**
- **NVIS operation providing virtually continuous HF coverage from 0 to 1000 km +**
- **Noise reduction - increased immunity to ignition and power line noise**

Short range HF coverage

As the 2018 predominantly radiates RF energy towards the ionosphere as a vehicle mounted NVIS (Near Vertical Incidence Sky wave) antenna, it is effective in overcoming the skip zone common in whip based antenna systems providing superior operation in the range of 30 to 150 kms. For the same reason the 2018 antenna is highly effective for communication in mountainous areas.

High performance

The 2018 mobile magnetic loop HF antenna is significantly more efficient than whip type vehicle antennas, producing considerably more efficient transmission and reception. The received signal relative to a whip antenna systems improves by +10 dB to +14 dB.

The 2018 antenna includes a built-in broadband scan amplifier which allows it to be used with systems containing Automatic Link Establishment (ALE) and multi-frequency networks operating in a Selective Calling scan group.

The radiation pattern of the 2018 antenna has low angle nulls toward each side of the vehicle, effectively reducing noise from adjacent power lines which commonly affect vehicles driving on remote roads that have high voltage distribution lines in close proximity.

Rugged construction

The 2018 Mobile magnetic loop HF antenna has been integrated in a roof rack, which allows it to be easily disguised in covert operations. The ground plane for the antenna is a heavy duty aluminium mesh floor, which is welded to the frame bars, maximising current within the radiating loop. Using a closed magnetic loop antenna design, the antenna effectively shields and isolates vehicle ignition noise thus providing greater clarity in communications.

The roof rack is field proven in some of the world's worst remote area conditions and is designed to withstand rough corrugated, pot holed and unsealed roads. Mounting hardware sets are available to suit most types of vehicles. Custom brackets can be made for all types of military vehicles.

Applications

- Border Patrol
- Customs
- Military
- Police
- Mining, Oil & Gas
- Emergency Services
- Conservation
- Paramilitary
- Aid & Relief
- Peace Keeping

General specifications

Frequency range	3.9 MHz to 12.2 MHz
Power supply	12 V to 13.8 V DC (provided from the transceiver)
Supply current	≤1.5 Amps peak, ≤400 mA standby
VSWR	Better than 2:1 when tuned
Power rating	125 W PEP
Polar radiation	Less than 5 dB variation at angles above 45° maximum power radiated towards zenith
Tune power	2 to 15 W
Tune time	Within 3 seconds
Tuning method	Continuously variable stepper motor
Temperature	Operating -30°C to 60°C
Humidity	95% non-condensing
Environmental rating	MIL-STD 810G (immersion). Fitted with a pressure equalising breather to equalise pressure without allowing the ingress of moisture. MIL-STD 810G for shock, vibration and dust

Specifications are typical. Equipment descriptions and specifications are subject to change without notice or obligation.

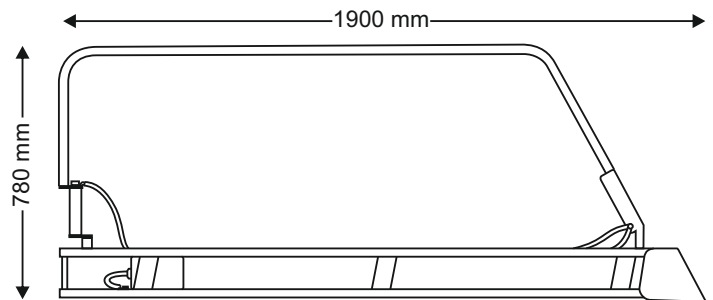

Side view deployed



End view stowed

Head Office:

Barrett Communications Pty Ltd
47 Discovery Drive, Bibra Lake,
WA, 6163 AUSTRALIA
Tel: +61 8 9434 1700
Fax: +61 8 9418 6757
Email: information@barrettcommunications.com.au

BCB20180/1

ISO 9001
BUREAU VERITAS
Certification

