



Key Features

- Ruggedized design for military applications
- The unit is man portable
- Compact and light-weight design, constructed from aluminium
- Designed to operate in extreme conditions
- Can operate on Diesel or AVTUR
- Has integral fuel tank for autonomous operation
- The unit can be parallel connected for higher load requirements
- Designed to meet stringent RFI/EMC requirements
- In service with military forces throughout the world
- Connection via NATO standard outlet socket
- Automatic engine speed control to minimise noise and fuel consumption
- External finish: 2 Pack Polyurethane Matt IRR or Powder Coating for durability

Military Packaged Generators

MPG002-LD

The MPG002 - LD is a two man portable 28vdc output, single cylinder air cooled generator capable of running on diesel or AVTUR and is designed to operate in the harshest of conditions. It is a compact, lightweight ruggedized design constructed from aluminium and incorporates an integral 3 litre fuel tank, which can be 'hot refuelled'.

It is economical to run, consuming less than 800ml/hr whilst on full load and is fitted with an intelligent control system which automatically adjusts the engine speed to match the load to minimise noise and fuel consumption.

It utilises a ruggedized marine standard high output alternator which is directly coupled to the engine, providing a full load output of 1500W at 28Vdc. The output connection is via a NATO standard 2 pole socket.

The engine is 'recoil' pull start with automatic decompression after pressing the 'ignition' push button to initiate the engine management control system. On the control panel there are status LED's as well as voltage and current meters indicating

its mode and output load draw. For military tactical use there is also the facility to 'black-out' all of the LED's.

The engine/alternator assembly within the units frame is resiliently mounted to minimise structural borne noise and stabilise its operation when deployed on solid ground.

The unit also has the ability to be secured within a vibration resistant frame which facilitates mounting to all-terrain vehicles for transportation.

The MPG002-LD is of a proven design and is in-service with current military services and meets stringent RFI/EMC requirements.

About CMCA

CMCA's Power Generation and Distribution Division designs and manufactures all types of electrical power generation equipment, including high-quality military mobile generators and auxiliary power units for the UK, NATO and international defence forces. Its products are state-of-the-art, innovative and efficient electrical power systems which offer the customer the ultimate combination of performance, versatility and reliability.



Facts and Figures

Overall Dimensions (nominal):

Width: 450mm
 Height: 525mm
 Length: 575mm

Weight: 56kg

Engine: Air Cooled

Starting Method: Manual Recoil

Fuel: Diesel or AVTUR
 Integral 3 litre fuel tank

Power Supply Output:

28Vdc, 1.5kW

Operating Conditions:

-20°C to +50°C

RFI/EMC Capabilities:

Designed to meet Def Stan 59-411 Land Class B

Further Information

For a full technical specification on this or any other CMCA product please contact:

Front Elevation

MPG002-LD

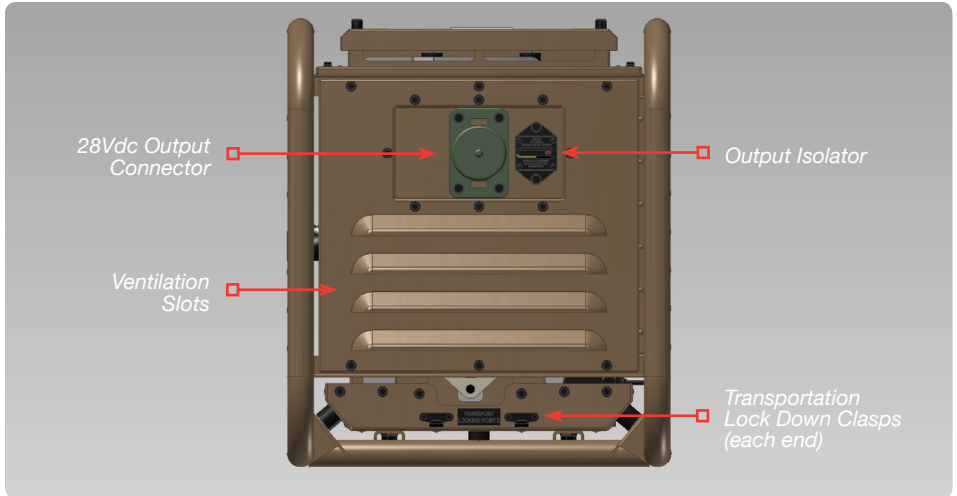

Side Elevation

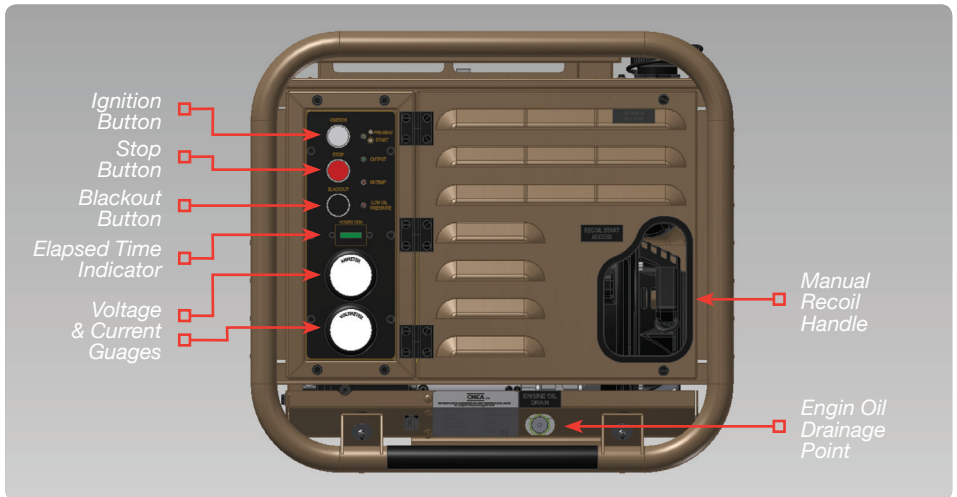

Plan View

