

Microwave Switches Selection Guide

Failsafe



SPDT

Latching



Up to 10T



High Power



DC to 40 GHz



Transfer



TELEDYNE
COAX SWITCHES
Everywhere you look™



RoHS or Non-RoHS:
Your Choice!



TELEDYNE
COAX SWITCHES
Everywhere you look™

teledynecoax.com

Switching Solutions

Industry Leader

With over 50 years experience, Teledyne is the world's innovative leader in manufacturing ultraminiature, hermetically sealed, electromechanical and solid-state switching products. Our comprehensive product line meets a wide range of requirements for industrial, commercial, medical, RF & wireless, defense and aerospace applications.

Product Assurance

Under an aggressive Total Quality Management (TQM) program, Teledyne has embraced a "continuous improvement" culture. With recognized certifications such as Boeing D6-82479, MIL-STD-790, AS/EN/JISQ9100:2009 (Rev C) and ISO 9001:2008, Teledyne has become a primary supplier of switching solutions with the highest quality and reliability to industry leaders around the world.

Product Development

Teledyne offers a full range of comprehensive switching solutions. In addition to offering standard switching solutions, our experienced team works closely with our customers to develop tailored products for specific applications. We offer advanced engineering, state-of-the-art manufacturing techniques, and over 50 years of switching experience with a commitment to quality, costs and delivery.

Standard & Custom Matrix Assemblies

Teledyne offers a wide variety of RF matrix assemblies. Incorporating highly repeatable and long-cycle-life relays and switches, our matrices cover the spectrum from DC to 40GHz.

Teledyne's modular approach to building matrices allows assembly of a vast array of customized matrices with the same standard subassemblies. The internal components utilize Teledyne's proven switches. Our universal programmable microcontroller can be used for any matrix configuration. The universal power supply allows the matrix assembly to be used worldwide. Teledyne is highly vertically integrated, which reduces development time, qualification time, cost and leadtime, while ensuring high quality and cost-effective production.

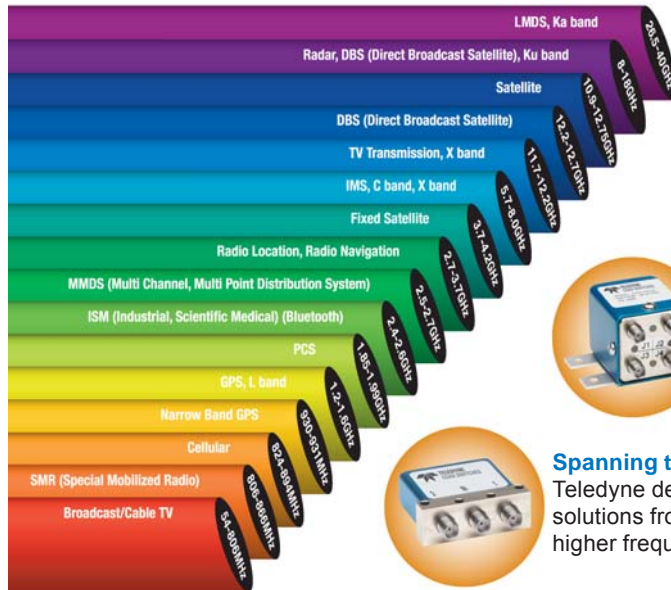

Spanning the Spectrum — Teledyne delivers switching solutions from DC to 40 GHz, with higher frequencies in development.

Featured switching solutions include:



Microwave Switch Matrix Assemblies

- Multiple standard and customized configurations
- Universal Power Supply
- Visual Display – LCD
- Standard and custom chassis available



CCR-40K DC–40 GHz SPDT Switch

- Excellent insertion loss repeatability
- Ultra low passive intermodulation (PIM)
- Characterized at 5 million cycles
- Compact design with 40 GHz performance



Matrix Assemblies — Teledyne provides matrix assemblies, such as the Model CSM-0003 1x40 Switch Matrix, that incorporate coaxial switches.

Space-Qualified Switches

Teledyne's space-qualified coaxial switches are typically custom-designed and manufactured according to specific performance requirements. We also provide a complete line of standard, off-the-shelf switches that offer customers significant cost savings, while satisfying most typical requirements for scientific, meteorological and communication satellite applications.

Technical Service & Customer Support

Teledyne provides easy access to technical service and customer support. Our website makes it easy to find technical information, buy products and even get e-mail responses within 24 hours. Switching solutions are only a mouse click away at www.teledynecoax.com.

Space-Qualified Switches

- Wide range of screening options available
- Custom designs to suit any application
- Proven heritage in space

(800) 351-7368

www.teledynecoax.com

TABLE OF CONTENTS

SERIES OVERVIEW	2-13
PART NUMBERING SYSTEM	14
SWITCH MATRIX	15
SPDT SWITCHES	16-25
2P3T SWITCHES	26-27
TRANSFER SWITCHES	28-31
MULTI-THROW SWITCHES.....	32-39
LOW PIM SWITCHES	40-48
SPECIALITY SWITCHES	49
TELEDYNE COAX SWITCH PERFORMANCE	50-51
GLOSSARY.....	56-57



TELEDYNE
COAX SWITCHES
Everywhereyoulook™

HEADQUARTERS

12525 Daphne Ave.
Hawthorne, CA 90250

Phone: (323) 777-0077 or
(800) 351-7368
Fax: (323) 241-1287

E-mail: coax@teledyne.com
www.teledynecoax.com

EUROPE

9-13 Napier Road • Wardpark North
Cumbernauld G68 OEF
Scotland UK

Phone: +44 (0) 1236 453 124
Fax: +44 (0) 1236 780 651

E-mail: sales_europe@teledyne.com
www.teledyne-europe.com



RoHS or Non-RoHS:
Your Choice!



Series (Commercial/Elite)		CCR-33/CR-33	CCR-53/CR-53	CCR-33K/CR-33K	CCR-40K/CR-40K
Configuration		SPDT	SPDT	SPDT	SPDT
Switch Function		Failsafe or Latching	Failsafe or Latching	Failsafe or Latching	Failsafe or Latching
Frequency	Commercial Model Elite Model	DC to 18 GHz DC to 22 GHz	DC to 26.5 GHz DC to 26.5 GHz	DC to 33.5 GHz DC to 33.5 GHz	DC to 40 GHz DC to 40 GHz
Coil Voltages Available		12, 15, 24, 28	12, 15, 24, 28	12, 15, 24, 28	12, 15, 24, 28
Connectors Available		SMA	SMA	2.92mm	2.92mm
Temperature Range	Commercial Model Elite Model	-40°C to +65°C -55°C to +85°C	-40°C to +65°C -55°C to +85°C	-40°C to +65°C -55°C to +85°C	-40°C to +65°C -55°C to +85°C
Special Features		Compact Package	High Frequency Performance	High Frequency Performance	High Frequency Performance
Typical Contact Life		5,000,000 cycles	5,000,000 cycles	5,000,000 cycles	5,000,000 cycles
Switch with Indicator Contacts		1,000,000 cycles	1,000,000 cycles	1,000,000 cycles	1,000,000 cycles
Typical RF Performance	VSWR (max)	DC-6 GHz : 1.10:1 6-12 GHz : 1.10:1 12-14 GHz : 1.20:1 14-18 GHz : 1.20:1	DC-4 GHz : 1.10:1 4-8 GHz : 1.10:1 8-12 GHz : 1.10:1 12-16 GHz : 1.20:1 16-20 GHz : 1.20:1 20-26.5 GHz : 1.30:1	DC-6 GHz : 1.10:1 6-12 GHz : 1.10:1 12-18 GHz : 1.20:1 18-24 GHz : 1.30:1 24-30 GHz : 1.40:1 30-33.5 GHz : 1.70:1	DC-6 GHz : 1.25:1 6-12 GHz : 1.40:1 12-18 GHz : 1.50:1 18-27 GHz : 1.60:1 27-34 GHz : 1.80:1 34-40 GHz : 1.80:1
	Insertion Loss (max)	DC-6 GHz : 0.10 dB 6-12 GHz : 0.10 dB 12-14 GHz : 0.20 dB 14-18 GHz : 0.30 dB	DC-4 GHz : 0.20 dB 4-8 GHz : 0.20 dB 8-12 GHz : 0.20 dB 12-16 GHz : 0.30 dB 16-20 GHz : 0.40 dB 20-26.5 GHz : 0.40 dB	DC-6 GHz : 0.20 dB 6-12 GHz : 0.20 dB 12-18 GHz : 0.30 dB 18-24 GHz : 0.40 dB 24-30 GHz : 0.40 dB 30-33.5 GHz : 0.70 dB	DC-6 GHz : 0.20 dB 6-12 GHz : 0.40 dB 12-18 GHz : 0.50 dB 18-27 GHz : 0.60 dB 27-34 GHz : 0.70 dB 34-40 GHz : 0.80 dB
	Isolation (min)	DC-6 GHz : 90 dB 6-12 GHz : 80 dB 12-14 GHz : 80 dB 14-18 GHz : 70 dB	DC-4 GHz : 90 dB 4-8 GHz : 90 dB 8-12 GHz : 80 dB 12-16 GHz : 75 dB 16-20 GHz : 65 dB 20-26.5 GHz : 50 dB	DC-6 GHz : 80 dB 6-12 GHz : 75 dB 12-18 GHz : 75 dB 18-24 GHz : 70 dB 24-30 GHz : 70 dB 30-33.5 GHz : 50 dB	DC-6 GHz : 70 dB 6-12 GHz : 60 dB 12-18 GHz : 60 dB 18-27 GHz : 50 dB 27-34 GHz : 50 dB 34-40 GHz : 50 dB
Options	Self Cutoff (Latching Only)	✓	✓	✓	✓
	Indicator Contacts	✓	✓	✓	✓
	Self Cutoff and Indicator Contacts (Latching Only)	✓	✓	✓	✓
	TTL Interface	✓	✓	✓	✓
	TTL Decoder	—	—	—	—
	Moisture Seal	✓	✓	✓	✓
	Narrow Body	✓	✓	✓	✓
	Coil Transient Suppression Diodes and Polarity Protection Diode	✓	✓	✓	✓
Sub-D Connector	✓	✓	✓	✓	
Typical Mechanical Outline		1.50 x 1.80 x .52 in. 38.1 x 45.7 x 13.2 mm See Page 16	1.50 x 1.80 x .52 in. 38.1 x 45.7 x 13.2 mm See Page 16	1.50 x 1.80 x .52 in. 38.1 x 45.7 x 13.2 mm See Page 16	1.50 x 1.82 x .52 in. 38.1 x 46.2 x 13.2 mm See Page 16



RoHS or Non-RoHS:
Your Choice!



Series (Commercial/Elite)		CCRT-33/CRT-33	CCRT-53/CRT-53	CCR-33M/CR-33M	CCS-32/CS-32
Configuration		SPDT	SPDT	SPDT	SPDT
Switch Function		Failsafe or Latching	Failsafe or Latching	Failsafe or Latching	Failsafe or Latching
Frequency	Commercial Model Elite Model	DC to 18 GHz DC to 22 GHz	DC to 26.5 GHz DC to 26.5 GHz	DC to 3 GHz DC to 3 GHz	DC to 12 GHz DC to 12 GHz
Coil Voltages Available		12, 15, 24, 28	12, 15, 24, 28	12, 15, 24, 28	12, 15, 24, 28
Connectors Available		SMA	SMA	Mini-SMB	N, TNC
Temperature Range	Commercial Model Elite Model	-40°C to +65°C -55°C to +85°C	-40°C to +65°C -55°C to +85°C	-40°C to +65°C -55°C to +85°C	-40°C to +65°C -55°C to +85°C
Special Features		50-Ohm Internal Termination	50-Ohm Internal Termination	75-Ohm Impedance	High RF Power Handling
Typical Contact Life Switch with Indicator Contacts		5,000,000 cycles 1,000,000 cycles	5,000,000 cycles 1,000,000 cycles	5,000,000 cycles 1,000,000 cycles	3,000,000 cycles 1,000,000 cycles
Typical RF Performance	VSWR (max)	DC-7 GHz : 1.10:1 7-12 GHz : 1.20:1 12-15 GHz : 1.40:1 15-18 GHz : 1.40:1	DC-6 GHz : 1.10:1 6-12 GHz : 1.20:1 12-18 GHz : 1.30:1 18-22 GHz : 1.50:1 22-26.5 GHz : 1.60:1	DC-1 GHz : 1.10:1 1-2 GHz : 1.20:1 2-3 GHz : 1.30:1	DC-3 GHz : 1.10:1 3-6 GHz : 1.20:1 6-9 GHz : 1.30:1 9-12 GHz : 1.40:1
	Insertion Loss (max)	DC-7 GHz : 0.10 dB 7-12 GHz : 0.20 dB 12-15 GHz : 0.20 dB 15-18 GHz : 0.30 dB	DC-6 GHz : 0.20 dB 6-12 GHz : 0.20 dB 12-18 GHz : 0.40 dB 18-22 GHz : 0.50 dB 22-26.5 GHz : 0.50 dB	DC-1 GHz : 0.10 dB 1-2 GHz : 0.20 dB 2-3 GHz : 0.20 dB	DC-3 GHz : 0.10 dB 3-6 GHz : 0.20 dB 6-9 GHz : 0.30 dB 9-12 GHz : 0.30 dB
	Isolation (min)	DC-7 GHz : 70 dB 7-12 GHz : 70 dB 12-15 GHz : 60 dB 15-18 GHz : 60 dB	DC-6 GHz : 80 dB 6-12 GHz : 80 dB 12-18 GHz : 70 dB 18-22 GHz : 70 dB 22-26.5 GHz : 55 dB	DC-1 GHz : 60 dB 1-2 GHz : 60 dB 2-3 GHz : 60 dB	DC-3 GHz : 70 dB 3-6 GHz : 70 dB 6-9 GHz : 65 dB 9-12 GHz : 65 dB
Options	Self Cutoff (Latching Only)	✓	✓	✓	✓
	Indicator Contacts	✓	✓	✓	✓
	Self Cutoff and Indicator Contacts (Latching Only)	✓	✓	✓	✓
	TTL Interface	✓	✓	✓	✓
	TTL Decoder	—	—	—	—
	Moisture Seal	✓	✓	✓	✓
	Narrow Body	—	—	✓	—
	Coil Transient Suppression Diodes and Polarity Protection Diode	✓	✓	✓	✓
Sub-D Connector	✓	✓	✓	✓	
Typical Mechanical Outline		2.06 x 2.05 x .56 in. 52.3 x 52.1 x 14.2 mm See Page 20	2.06 x 2.05 x .56 in. 52.3 x 52.1 x 14.2 mm See Page 20	1.50 x 1.80 x .52 in. 38.1 x 45.7 x 13.2 mm See Page 22	2.75 x 2.30 x .90 in. 69.9 x 58.4 x 22.9 mm See Page 24



RoHS or Non-RoHS:
Your Choice!



Series (Commercial/Elite)		CCRS-33/CRS-33	CCRS-53/CRS-53	CCS-37/CS-37	CCS-47/CS-47
Configuration		2P3T	2P3T	Transfer Switch	Transfer Switch
Switch Function		Failsafe or Latching	Failsafe or Latching	Failsafe or Latching	Failsafe or Latching
Frequency	Commercial Model Elite Model	DC to 18 GHz DC to 18 GHz	DC to 26.5 GHz DC to 26.5 GHz	DC to 18 GHz DC to 18 GHz	DC to 12 GHz DC to 12 GHz
Coil Voltages Available		12, 15, 24, 28	12, 15, 24, 28	12, 15, 24, 28	12, 15, 24, 28
Connectors Available		SMA	SMA	SMA	TNC, N
Temperature Range	Commercial Model Elite Model	-40°C to +65°C -55°C to +85°C	-40°C to +65°C -55°C to +85°C	-40°C to +65°C -55°C to +85°C	-40°C to +65°C -55°C to +85°C
Special Features		Multiport	High Frequency Multiport	Compact Package	High RF Power Handling
Typical Contact Life		5,000,000 cycles	5,000,000 cycles	5,000,000 cycles	3,000,000 cycles
Switch with Indicator Contacts		1,000,000 cycles	1,000,000 cycles	1,000,000 cycles	1,000,000 cycles
Typical RF Performance	VSWR (max)	DC-7 GHz : 1.10:1 7-12 GHz : 1.20:1 12-15 GHz : 1.30:1 15-18 GHz : 1.30:1	DC-6 GHz : 1.10:1 6-12 GHz : 1.20:1 12-18 GHz : 1.20:1 18-22 GHz : 1.40:1 22-26.5 GHz : 1.50:1	DC-5 GHz : 1.10:1 5-10 GHz : 1.20:1 10-13 GHz : 1.30:1 13-15 GHz : 1.60:1 15-18 GHz : 1.60:1	DC-2 GHz : 1.20:1 2-5 GHz : 1.20:1 5-8 GHz : 1.30:1 8-10 GHz : 1.50:1 10-12 GHz : 1.50:1
	Insertion Loss (max)	DC-7 GHz : 0.10 dB 7-12 GHz : 0.10 dB 12-15 GHz : 0.20 dB 15-18 GHz : 0.20 dB	DC-6 GHz : 0.10 dB 6-12 GHz : 0.20 dB 12-18 GHz : 0.30 dB 18-22 GHz : 0.40 dB 22-26.5 GHz : 0.60 dB	DC-5 GHz : 0.10 dB 5-10 GHz : 0.20 dB 10-13 GHz : 0.20 dB 13-15 GHz : 0.50 dB 15-18 GHz : 0.50 dB	DC-2 GHz : 0.10 dB 2-5 GHz : 0.20 dB 5-8 GHz : 0.20 dB 8-10 GHz : 0.40 dB 10-12 GHz : 0.40 dB
	Isolation (min)	DC-7 GHz : 70 dB 7-12 GHz : 70 dB 12-15 GHz : 65 dB 12-18 GHz : 65 dB	DC-6 GHz : 80 dB 6-12 GHz : 75 dB 12-18 GHz : 75 dB 18-22 GHz : 70 dB 22-26.5 GHz : 60 dB	DC-5 GHz : 80 dB 5-10 GHz : 80 dB 10-13 GHz : 80 dB 13-15 GHz : 80 dB 15-18 GHz : 80 dB	DC-2 GHz : 70 dB 2-5 GHz : 70 dB 5-8 GHz : 70 dB 8-10 GHz : 60 dB 10-12 GHz : 60 dB
Options	Self Cutoff (Latching Only)	✓	✓	✓	✓
	Indicator Contacts	✓	✓	✓	✓
	Self Cutoff and Indicator Contacts (Latching Only)	✓	✓	✓	✓
	TTL Interface	✓	✓	✓	✓
	TTL Decoder	—	—	—	—
	Moisture Seal	✓	✓	✓	✓
	Narrow Body	—	—	—	—
	Coil Transient Suppression Diodes and Polarity Protection Diode	✓	✓	✓	✓
Sub-D Connector	✓	✓	✓	✓	
Typical Mechanical Outline		2.06 x 1.90 x .56 in. 52.3 x 48.3 x 14.2 mm See Page 26	2.06 x 1.90 x .56 in. 52.3 x 48.3 x 14.2 mm See Page 26	2.19 x 2.00 x 1.37 in. 55.6 x 50.8 x 34.8 mm See Page 28	3.12 x 2.60 x 1.81 in. 79.2 x 66.1 x 46 mm See Page 30



Series (Commercial/Elite)		CCR-38/CR-38	CCR-38	CCR-38	CCR-58/CR-58
Configuration		SP3T to SP6T	SP7T to SP8T	SP9T to SP10T	SP3T to SP6T
Switch Function		Normally Open	Normally Open	Normally Open	Normally Open
Frequency	Commercial Model Elite Model	DC to 18 GHz DC to 22 GHz	DC to 12.4 GHz	DC to 10 GHz	DC to 26.5 GHz DC to 26.5 GHz
Coil Voltages Available		12, 15, 24, 28	12, 15, 24, 28	12, 15, 24, 28	12, 15, 24, 28
Connectors Available		SMA	SMA	SMA	SMA
Temperature Range	Commercial Model Elite Model	-40°C to +65°C -55°C to +85°C	-40°C to +65°C	-40°C to +65°C	-40°C to +65°C -55°C to +85°C
Special Features		Multi-throw	Multi-throw	Multi-throw	High Frequency Multi-throw
Typical Contact Life Switch with Indicator Contacts		5,000,000 cycles 1,000,000 cycles	3,000,000 cycles 1,000,000 cycles	3,000,000 cycles 1,000,000 cycles	5,000,000 cycles 1,000,000 cycles
Typical RF Performance	VSWR (max)	DC-4 GHz : 1.05:1 4-8 GHz : 1.10:1 8-12 GHz : 1.20:1 12-16 GHz : 1.20:1 16-20 GHz : 1.20:1 20-22 GHz : 1.20:1	DC-2.3 GHz : 1.15:1 2.3-3 GHz : 1.20:1 3-8 GHz : 1.30:1 8-12.4 GHz : 1.40:1	DC-2.3 GHz : 1.15:1 2.3-3 GHz : 1.20:1 3-6 GHz : 1.30:1 6-8 GHz : 1.40:1 8-10 GHz : 1.60:1	DC-4 GHz : 1.05:1 4-8 GHz : 1.10:1 8-12 GHz : 1.20:1 12-16 GHz : 1.20:1 16-20 GHz : 1.20:1 20-22 GHz : 1.20:1
	Insertion Loss (max)	DC-4 GHz : 0.10 dB 4-8 GHz : 0.20 dB 8-12 GHz : 0.20 dB 12-16 GHz : 0.30 dB 16-20 GHz : 0.30 dB 20-22 GHz : 0.30 dB	DC-2.3 GHz : 0.20 dB 2.3-3 GHz : 0.25 dB 3-8 GHz : 0.30 dB 8-12.4 GHz : 0.40 dB	DC-2.3 GHz : 0.20 dB 2.3-3 GHz : 0.25 dB 3-6 GHz : 0.30 dB 6-8 GHz : 0.40 dB 8-10 GHz : 0.60 dB	DC-4 GHz : 0.10 dB 4-8 GHz : 0.20 dB 8-12 GHz : 0.20 dB 12-16 GHz : 0.30 dB 16-20 GHz : 0.30 dB 20-22 GHz : 0.30 dB
	Isolation (min)	DC-4 GHz : 80 dB 4-8 GHz : 80 dB 8-12 GHz : 80 dB 12-16 GHz : 80 dB 16-20 GHz : 75 dB 20-22 GHz : 75 dB	DC-2.3 GHz : 80 dB 2.3-3 GHz : 70 dB 3-8 GHz : 65 dB 8-12.4 GHz : 60 dB	DC-2.3 GHz : 80 dB 2.3-3 GHz : 70 dB 3-6 GHz : 65 dB 6-8 GHz : 60 dB 8-10 GHz : 60 dB	DC-4 GHz : 80 dB 4-8 GHz : 80 dB 8-12 GHz : 80 dB 12-16 GHz : 80 dB 16-20 GHz : 75 dB 20-22 GHz : 75 dB
Options	Self Cutoff (Latching Only)	—	—	—	—
	Indicator Contacts	✓	✓	✓	✓
	Self Cutoff and Indicator Contacts (Latching Only)	—	—	—	—
	TTL Interface	✓	✓	✓	✓
	TTL Decoder	✓	✓	✓	✓
	Moisture Seal	✓	✓	✓	✓
	Narrow Body	—	—	—	—
	Coil Transient Suppression Diodes and Polarity Protection Diode	✓	✓	✓	✓
Sub-D Connector	✓	✓	✓	✓	
Typical Mechanical Outline		1.75 x 2.27 x 1.75 in. 44.5 x 57.7 x 44.5 mm See Page 32	2.50 x 2.87 x 2.50 in. 63.5 x 72.9 x 63.5 mm See Page 34	3.10 x 2.77 x 3.10 in. 78.7 x 70.4 x 78.7 mm See Page 34	1.75 x 2.50 x 1.75 in. 44.5 x 63.5 x 44.5 mm See Page 32



RoHS or Non-RoHS:
Your Choice!



Series (Commercial/Elite)		CCT-38/CT-38	CCT-38	CCT-38	CCT-58/CT-58
Configuration		SP3T to SP6T	SP7T to SP8T	SP9T to SP10T	SP3T to SP6T
Switch Function		Normally Open	Normally Open	Normally Open	Normally Open
Frequency	Commercial Model Elite Model	DC to 18 GHz DC to 22 GHz	DC to 12.4 GHz	DC to 10 GHz	DC to 26.5 GHz DC to 26.5 GHz
Coil Voltages Available		12, 15, 24, 28	12, 15, 24, 28	12, 15, 24, 28	12, 15, 24, 28
Connectors Available		SMA	SMA	SMA	SMA
Temperature Range	Commercial Model Elite Model	-40°C to +65°C -55°C to +85°C	-40°C to +65°C	-40°C to +65°C	-40°C to +65°C -55°C to +85°C
Special Features		50-Ohm Internal Termination	50-Ohm Internal Termination	50-Ohm Internal Termination	50-Ohm Internal Termination
Typical Contact Life Switch with Indicator Contacts		5,000,000 cycles 1,000,000 cycles	3,000,000 cycles 1,000,000 cycles	3,000,000 cycles 1,000,000 cycles	5,000,000 cycles 1,000,000 cycles
Typical RF Performance	VSWR (max)	DC-4 GHz : 1.05:1 4-8 GHz : 1.10:1 8-12 GHz : 1.20:1 12-16 GHz : 1.20:1 16-20 GHz : 1.20:1 20-22 GHz : 1.20:1	DC-2.3 GHz : 1.15:1 2.3-3 GHz : 1.20:1 3-8 GHz : 1.30:1 8-12.4 GHz : 1.40:1	DC-2.3 GHz : 1.15:1 2.3-3 GHz : 1.20:1 3-6 GHz : 1.30:1 6-8 GHz : 1.40:1 8-10 GHz : 1.60:1	DC-4 GHz : 1.05:1 4-8 GHz : 1.10:1 8-12 GHz : 1.20:1 12-16 GHz : 1.20:1 16-20 GHz : 1.20:1 20-22 GHz : 1.20:1
	Insertion Loss (max)	DC-4 GHz : 0.10 dB 4-8 GHz : 0.20 dB 8-12 GHz : 0.20 dB 12-16 GHz : 0.30 dB 16-20 GHz : 0.30 dB 20-22 GHz : 0.30 dB	DC-2.3 GHz : 0.20 dB 2.3-3 GHz : 0.25 dB 3-8 GHz : 0.30 dB 8-12.4 GHz : 0.40 dB	DC-2.3 GHz : 0.20 dB 2.3-3 GHz : 0.25 dB 3-6 GHz : 0.30 dB 6-8 GHz : 0.40 dB 8-10 GHz : 0.60 dB	DC-4 GHz : 0.10 dB 4-8 GHz : 0.20 dB 8-12 GHz : 0.20 dB 12-16 GHz : 0.30 dB 16-20 GHz : 0.30 dB 20-22 GHz : 0.30 dB
	Isolation (min)	DC-4 GHz : 80 dB 4-8 GHz : 80 dB 8-12 GHz : 80 dB 12-16 GHz : 80 dB 16-20 GHz : 75 dB 20-22 GHz : 75 dB	DC-2.3 GHz : 80 dB 2.3-3 GHz : 70 dB 3-8 GHz : 65 dB 8-12.4 GHz : 60 dB	DC-2.3 GHz : 80 dB 2.3-3 GHz : 70 dB 3-6 GHz : 65 dB 6-8 GHz : 60 dB 8-10 GHz : 60 dB	DC-4 GHz : 80 dB 4-8 GHz : 80 dB 8-12 GHz : 80 dB 12-16 GHz : 80 dB 16-20 GHz : 75 dB 20-22 GHz : 75 dB
Options	Self Cutoff (Latching Only)	—	—	—	—
	Indicator Contacts	✓	✓	✓	✓
	Self Cutoff and Indicator Contacts (Latching Only)	—	—	—	—
	TTL Interface	✓	✓	✓	✓
	TTL Decoder	✓	✓	✓	✓
	Moisture Seal	✓	✓	✓	✓
	Narrow Body	—	—	—	—
	Coil Transient Suppression Diodes and Polarity Protection Diode	✓	✓	✓	✓
Sub-D Connector	✓	✓	✓	✓	
Typical Mechanical Outline		2.25 x 2.50 x 2.25 in. 57.2 x 63.5 x 57.2 mm See Page 32	2.50 x 2.87 x 2.50 in. 63.5 x 72.9 x 63.5 mm See Page 34	3.10 x 2.77 x 3.10 in. 78.7 x 70.4 x 78.7 mm See Page 34	2.25 x 2.50 x 2.25 in. 57.2 x 63.5 x 57.2 mm See Page 32



Series (Commercial/Elite)		CCR-39/CR-39	CCR-39	CCR-39	CCR-59/CR-59
Configuration		SP3T to SP6T	SP7T to SP8T	SP9T to SP10T	SP3T to SP6T
Switch Function		Latching	Latching	Latching	Latching
Frequency	Commercial Model Elite Model	DC to 18 GHz DC to 22 GHz	DC to 12 GHz	DC to 10 GHz	DC to 26.5 GHz DC to 26.5 GHz
Coil Voltages Available		12, 15, 24, 28	12, 15, 24, 28	12, 15, 24, 28	12, 15, 24, 28
Connectors Available		SMA	SMA	SMA	SMA
Temperature Range	Commercial Model Elite Model	-40°C to +65°C -55°C to +85°C	-40°C to +65°C	-40°C to +65°C	-40°C to +65°C -55°C to +85°C
Special Features		Multi-throw	Multi-throw	Multi-throw	High Frequency Multi-throw
Typical Contact Life		5,000,000 cycles	3,000,000 cycles	3,000,000 cycles	5,000,000 cycles
Switch with Indicator Contacts		1,000,000 cycles	1,000,000 cycles	1,000,000 cycles	1,000,000 cycles
Typical RF Performance	VSWR (max)	DC-4 GHz : 1.05:1 4-8 GHz : 1.10:1 8-12 GHz : 1.20:1 12-16 GHz : 1.20:1 16-20 GHz : 1.20:1 20-22 GHz : 1.20:1	DC-6 GHz : 1.10:1 6-12 GHz : 1.25:1	DC-4 GHz : 1.10:1 4-8 GHz : 1.25:1 8-10 GHz : 1.30:1	DC-4 GHz : 1.05:1 4-8 GHz : 1.10:1 8-12 GHz : 1.20:1 12-16 GHz : 1.20:1 16-20 GHz : 1.20:1 20-22 GHz : 1.20:1
	Insertion Loss (max)	DC-4 GHz : 0.10 dB 4-8 GHz : 0.20 dB 8-12 GHz : 0.20 dB 12-16 GHz : 0.30 dB 16-20 GHz : 0.30 dB 20-22 GHz : 0.30 dB	DC-6 GHz : 0.10 dB 6-12 GHz : 0.20 dB	DC-4 GHz : 0.10 dB 4-8 GHz : 0.20 dB 8-10 GHz : 0.30 dB	DC-4 GHz : 0.10 dB 4-8 GHz : 0.20 dB 8-12 GHz : 0.20 dB 12-16 GHz : 0.30 dB 16-20 GHz : 0.30 dB 20-22 GHz : 0.30 dB
	Isolation (min)	DC-4 GHz : 80 dB 4-8 GHz : 80 dB 8-12 GHz : 80 dB 12-16 GHz : 80 dB 16-20 GHz : 75 dB 20-22 GHz : 75 dB	DC-6 GHz : 80 dB 6-12 GHz : 80 dB	DC-4 GHz : 80 dB 4-8 GHz : 80 dB 8-10 GHz : 80 dB	DC-4 GHz : 80 dB 4-8 GHz : 80 dB 8-12 GHz : 80 dB 12-16 GHz : 80 dB 16-20 GHz : 75 dB 20-22 GHz : 75 dB
Options	Self Cutoff (Latching Only)	✓	✓	✓	✓
	Indicator Contacts	✓	✓	✓	✓
	Self Cutoff and Indicator Contacts (Latching Only)	✓	✓	✓	✓
	TTL Interface	✓	✓	✓	✓
	TTL Decoder	✓	✓	✓	✓
	Moisture Seal	✓	✓	✓	✓
	Narrow Body	—	—	—	—
	Coil Transient Suppression Diodes and Polarity Protection Diode	✓	✓	✓	✓
Sub-D Connector	✓	✓	✓	✓	
Typical Mechanical Outline		2.25 x 2.50 x 2.25 in. 57.2 x 63.5 x 57.2 mm See Page 32	2.50 x 2.87 x 2.50 in. 63.5 x 72.9 x 63.5 mm See Page 35	3.10 x 2.77 x 3.10 in. 78.7 x 70.4 x 78.7 mm See Page 35	2.25 x 2.50 x 2.25 in. 57.2 x 63.5 x 57.2 mm See Page 32



RoHS or Non-RoHS:
Your Choice!



Series (Commercial/Elite)		CCT-39/CT-39	CCT-39	CCT-39	CCT-59/CT-59
Configuration		SP3T to SP6T	SP7T to SP8T	SP9T to SP10T	SP3T to SP6T
Switch Function		Latching	Latching	Latching	Latching
Frequency	Commercial Model Elite Model	DC to 18 GHz DC to 22 GHz	DC to 12 GHz	DC to 10 GHz	DC to 26.5 GHz DC to 26.5 GHz
Coil Voltages Available		12, 15, 24, 28	12, 15, 24, 28	12, 15, 24, 28	12, 15, 24, 28
Connectors Available		SMA	SMA	SMA	SMA
Temperature Range	Commercial Model Elite Model	-40°C to +65°C -55°C to +85°C	-40°C to +65°C	-40°C to +65°C	-40°C to +65°C -55°C to +85°C
Special Features		50-Ohm Internal Termination	50-Ohm Internal Termination	50-Ohm Internal Termination	High Frequency Terminated
Typical Contact Life Switch with Indicator Contacts		5,000,000 cycles 1,000,000 cycles	3,000,000 cycles 1,000,000 cycles	3,000,000 cycles 1,000,000 cycles	5,000,000 cycles 1,000,000 cycles
Typical RF Performance	VSWR (max)	DC-4 GHz : 1.05:1 4-8 GHz : 1.10:1 8-12 GHz : 1.20:1 12-16 GHz : 1.20:1 16-20 GHz : 1.20:1 20-22 GHz : 1.20:1	DC-6 GHz : 1.30:1 6-12 GHz : 1.40:1	DC-4 GHz : 1.10:1 4-8 GHz : 1.25:1 8-10 GHz : 1.30:1	DC-4 GHz : 1.05:1 4-8 GHz : 1.10:1 8-12 GHz : 1.20:1 12-16 GHz : 1.20:1 16-20 GHz : 1.20:1 20-22 GHz : 1.20:1
	Insertion Loss (max)	DC-4 GHz : 0.10 dB 4-8 GHz : 0.20 dB 8-12 GHz : 0.20 dB 12-16 GHz : 0.30 dB 16-20 GHz : 0.30 dB 20-22 GHz : 0.30 dB	DC-6 GHz : 0.20 dB 6-12 GHz : 0.40 dB	DC-4 GHz : 0.10 dB 4-8 GHz : 0.20 dB 8-10 GHz : 0.30 dB	DC-4 GHz : 0.10 dB 4-8 GHz : 0.20 dB 8-12 GHz : 0.20 dB 12-16 GHz : 0.30 dB 16-20 GHz : 0.30 dB 20-22 GHz : 0.30 dB
	Isolation (min)	DC-4 GHz : 80 dB 4-8 GHz : 80 dB 8-12 GHz : 80 dB 12-16 GHz : 80 dB 16-20 GHz : 75 dB 20-22 GHz : 75 dB	DC-6 GHz : 70 dB 6-12 GHz : 60 dB	DC-4 GHz : 80 dB 4-8 GHz : 80 dB 8-10 GHz : 80 dB	DC-4 GHz : 80 dB 4-8 GHz : 80 dB 8-12 GHz : 80 dB 12-16 GHz : 80 dB 16-20 GHz : 75 dB 20-22 GHz : 75 dB
Options	Self Cutoff (Latching Only)	✓	✓	✓	✓
	Indicator Contacts	✓	✓	✓	✓
	Self Cutoff and Indicator Contacts (Latching Only)	✓	✓	✓	✓
	TTL Interface	✓	✓	✓	✓
	TTL Decoder	✓	✓	✓	✓
	Moisture Seal	✓	✓	✓	✓
	Narrow Body	—	—	—	—
	Coil Transient Suppression Diodes and Polarity Protection Diode	✓	✓	✓	✓
Sub-D Connector	✓	✓	✓	✓	
Typical Mechanical Outline		2.25 x 2.50 x 2.25 in. 57.2 x 63.5 x 57.2 mm See Page 32	2.50 x 2.87 x 2.50 in. 63.5 x 72.9 x 63.5 mm See Page 35	3.10 x 2.77 x 3.10 in. 78.7 x 70.4 x 78.7 mm See Page 35	2.25 x 2.50 x 2.25 in. 57.2 x 63.5 x 57.2 mm See Page 32



Series (Commercial/Elite)		CCS-18/CS-18	CCS-19/CS-19	CCP-33S	CCP-32N
Configuration		SP3T to SP8T	SP3T to SP6T	SPDT	SPDT
Switch Function		Normally Open	Latching	Latching	Latching
Frequency	Commercial Model Elite Model	DC to 12 GHz DC to 12 GHz	DC to 12 GHz DC to 12 GHz	DC to 3 GHz	DC to 3 GHz
Coil Voltages Available		12, 15, 24, 28	12, 15, 24, 28	12, 15, 24, 28	12, 15, 24, 28
Connectors Available		N, TNC	N, TNC	SMA	N
Temperature Range	Commercial Model Elite Model	-40°C to +65°C -55°C to +85°C	-40°C to +65°C -55°C to +85°C	-40°C to +65°C	-40°C to +65°C
Special Features		High RF Power Handling	High RF Power Handling	Low PIM	Low PIM
Typical Contact Life Switch with Indicator Contacts		3,000,000 cycles 1,000,000 cycles	3,000,000 cycles 1,000,000 cycles	1,000,000 cycles 1,000,000 cycles	1,000,000 cycles 1,000,000 cycles
Typical RF Performance		DC-3 GHz : 1.30:1 3-6 GHz : 1.30:1 6-9 GHz : 1.40:1 9-12 GHz : 1.70:1	DC-4 GHz : 1.10:1 4-8 GHz : 1.25:1 8-12 GHz : 1.30:1	3rd Order Intermodulation: 1900 MHz -142.2 dBc Peak PIM	3rd Order Intermodulation: 1900 MHz -148.6 dBc Peak PIM
		DC-3 GHz : 0.20 dB 3-6 GHz : 0.20 dB 6-9 GHz : 0.30 dB 9-12 GHz : 0.40 dB	DC-4 GHz : 0.10 dB 4-8 GHz : 0.20 dB 8-12 GHz : 0.30 dB	Tone 1 Frequency: 1945 MHz @ 43 dBm	Tone 1 Frequency: 1945 MHz @ 43 dBm
		DC-3 GHz : 80 dB 3-6 GHz : 80 dB 6-9 GHz : 80 dB 9-12 GHz : 70 dB	DC-3 GHz : 80 dB 3-6 GHz : 80 dB 6-9 GHz : 80 dB	Tone 2 Frequency: 1990 MHz @ 43 dBm	Tone 2 Frequency: 1990 MHz @ 43 dBm
Options	Self Cutoff (Latching Only)	—	—	✓	✓
	Indicator Contacts	✓	✓	✓	✓
	Self Cutoff and Indicator Contacts (Latching Only)	—	✓	✓	✓
	TTL Interface	✓	✓	✓	✓
	TTL Decoder	✓	✓	—	—
	Moisture Seal	✓	✓	✓	✓
	Narrow Body	—	—	✓	—
	Coil Transient Suppression Diodes and Polarity Protection Diode	✓	✓	✓	✓
	Sub-D Connector	✓	✓	✓	✓
Typical Mechanical Outline		3.08 x 2.65 x 3.25 in. 78.2 x 67.3 x 82.5 mm See Page 36	2.50 x 3.54 x 2.50 in. 63.5 x 89.9 x 63.5 mm See Page 38	1.34 x 1.97 x 0.52 in. 34.0 x 50.0 x 13.2 mm See Page 40	2.75 x 2.33 x 0.90 in. 69.9 x 59.2 x 22.7 mm See Page 41



RoHS or Non-RoHS:
Your Choice!



Series (Commercial)		CCP-33D	CCP-37S	CCP-47N	CCP-47D
Configuration		SPDT	Transfer Switch	Transfer Switch	Transfer Switch
Switch Function		Latching	Latching	Latching	Latching
Frequency	Commercial Model	DC to 3 GHz	DC to 3 GHz	DC to 3 GHz	DC to 3 GHz
Coil Voltages Available		12, 15, 24, 28	12, 15, 24, 28	12, 15, 24, 28	12, 15, 24, 28
Connectors Available		7/16 DIN	SMA	N	7/16 DIN
Temperature Range	Commercial Model	-40°C to +65°C	-40°C to +65°C	-25°C to +65°C	-25°C to +65°C
Special Feature		Low PIM	Low PIM	Low PIM	Low PIM
Typical Contact Life		1,000,000 cycles	1,000,000 cycles	1,000,000 cycles	1,000,000 cycles
Switch with Indicator Contacts		1,000,000 cycles	1,000,000 cycles	1,000,000 cycles	1,000,000 cycles
Passive Intermodulation Characteristics	3rd Order Intermodulation:	1900 MHz -165.6 dBc Peak PIM	1900 MHz -146.7 dBc Peak PIM	1900 MHz -159.2 dBc Peak PIM	1900 MHz -165.5 dBc Peak PIM
	Tone 1 Frequency:	1945 MHz @ 43 dBm	1945 MHz @ 43 dBm	1945 MHz @ 43 dBm	1945 MHz @ 43 dBm
	Tone 2 Frequency:	1990 MHz @ 43 dBm	1990 MHz @ 43 dBm	1990 MHz @ 43 dBm	1990 MHz @ 43 dBm
Options	Self Cutoff (Latching Only)	✓	✓	✓	✓
	Indicator Contacts	✓	✓	✓	✓
	Self Cutoff and Indicator Contacts (Latching Only)	✓	✓	✓	✓
	TTL Interface	✓	✓	✓	✓
	TTL Decoder	—	—	—	—
	Moisture Seal	✓	✓	✓	✓
	Narrow Body	—	—	—	—
	Coil Transient Suppression Diodes and Polarity Protection Diode	✓	✓	✓	✓
Sub-D Connector	✓	✓	✓	✓	
Typical Mechanical Outline		3.50 x 3.97 x 3.50 in. 88.9 x 100.8 x 88.9 mm See Page 42	2.16 x 2.27 x 1.32 in. 54.86 x 57.7 x 33.5 mm See Page 43	3.12 x 3.48 x 1.81 in. 79.24 x 88.4 x 45.9 mm See Page 44	3.50 x 3.97 x 3.50 in. 88.9 x 100.8 x 88.9 mm See Page 45



Series (Commercial)		CCP-18D	CCP-38S	CCP-18N
Configuration		SP3T to SP4T	SP3T to SP8T	SP3T to SP6T
Switch Function		Normally Open	Normally Open	Normally Open
Frequency	Commercial Model	DC to 3 GHz	DC to 3 GHz	DC to 3 GHz
Coil Voltages Available		12, 15, 24, 28	12, 15, 24, 28	12, 15, 24, 28
Connectors Available		7/16 DIN	SMA	N
Temperature Range	Commercial Model	-40°C to +65°C	-40°C to +65°C	-40°C to +65°C
Special Features		Low PIM	Low PIM	Low PIM
Typical Contact Life		1,000,000 cycles	1,000,000 cycles	1,000,000 cycles
Switch with Indicator Contacts		1,000,000 cycles	1,000,000 cycles	1,000,000 cycles
Passive Intermodulation Characteristics	3rd Order Intermodulation: 1900 MHz -156.6 dBc Peak PIM	3rd Order Intermodulation: 1900 MHz -144.1 dBc Peak PIM	3rd Order Intermodulation: 1900 MHz -146.7 dBc Peak PIM	
	Tone 1 Frequency: 1945 MHz @ 43 dBm	Tone 1 Frequency: 1945 MHz @ 43 dBm	Tone 1 Frequency: 1945 MHz @ 43 dBm	
	Tone 2 Frequency: 1990 MHz @ 43 dBm	Tone 2 Frequency: 1990 MHz @ 43 dBm	Tone 2 Frequency: 1990 MHz @ 43 dBm	
Options	Self Cutoff (Latching Only)	—	—	—
	Indicator Contacts	✓	✓	✓
	Self Cutoff and Indicator Contacts (Latching Only)	—	—	—
	TTL Interface	✓	✓	✓
	TTL Decoder	✓	✓	✓
	Moisture Seal	✓	✓	✓
	Narrow Body	—	—	—
	Coil Transient Suppression Diodes and Polarity Protection Diode	✓	✓	✓
Sub-D Connector	✓	✓	✓	
Typical Mechanical Outline	4.01 x 4.27 x 4.01 in. 88.9 x 108.5 x 101.9 mm See Page 46	1.75 x 2.62 x 1.75 in. 88.9 x 66.5 x 44.5 mm See Page 47	2.50 x 3.14 x 2.50 in. 88.9 x 79.8 x 63.5 mm See Page 48	



RoHS or Non-RoHS:
Your Choice!



Series		CAS-37	
RF Contacts	3 State Attenuator Switch	Special Feature	3-States: Thru Path Attenuated Path, 20 dB 50 Ohm Internal Termination
Typical Contact Life	1,000,000 cycles		
Frequency	DC to 25 GHz	Weight	4 oz. (113.4 g) (max)
Coil Voltage	12, 15, 24, 28	Typical Mechanical Outline	1.27 x 2.25 x 1.37 in. 38.1 x 46.2 x 13.2 mm See Page 8
Connector	SMA	Shock	MIL-STD-202 Method 213, Condition D (500G Non Operating)
Temperature Range	0°C to +55°C	Vibration	MIL-STD-202 Method 214, Condition D (5G RMS Non Operating)
Typical RF Performance	VSWR, 20 dB Path (max)	DC–3 GHz : 1.11:1 3–9 GHz : 1.20:1 9–13 GHz : 1.50:1 13–18 GHz : 1.45:1 18–21 GHz : 1.80:1 21–25 GHz : 2.80:1	VSWR, Thru Path (max) DC–3 GHz : 1.11:1 3–9 GHz : 1.20:1 9–13 GHz : 1.25:1 13–18 GHz : 1.33:1 18–21 GHz : 1.33:1 21–25 GHz : 1.50:1
	Insertion Loss, Thru Path (max)	DC–3GHz : 0.35 dB 3–9 GHz : 0.48 dB 9–13 GHz : 0.63 dB 13–18 GHz : 0.75 dB 18–21 GHz : 0.93 dB 21–25 GHz : 1.10 dB	Isolation, Terminated State DC–3 GHz : >60 dB 3–9 GHz : >60 dB 9–13 GHz : >60 dB 13–18 GHz : >60 dB 18–21 GHz : >60 dB 21–25 GHz : >60 dB
Attenuation, 20 dB (dB max/min)	Frequency DC–3 GHz: 3–9 GHz: 9–13 GHz: 13–18 GHz: 18–21 GHz: 21–25 GHz:	Max. + .28 dB + .48 dB + .83 dB + 1.12 dB + 1.55 dB + 1.95 dB	Min. - .40 dB - .40 dB - .41 dB - .48 dB - .56 dB - .65 dB

See Page 49

Additional Unique Options

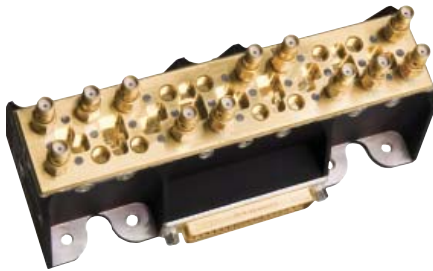

Switch Blocks



Alternative Connector Locations



Radiation Shielding Covers



6P7T Switch

Teledyne Coax Switches offers numerous options for coaxial switches:

- Double Insulation
- Radiation Shielding
- Customized Mounting Brackets
- Special Power Connectors
- Alternate RF Connectors
- Alternate DC terminal styles
- Short Covers
- PCB Mount RF Pins
- Switch Blocks
- 6P7T Switch Matrix
- Parallel or Series Diodes
- Redundant Diode Configuration
- Pressure Evacuation Vent



PCB Pin Option



Short Cover Option



DC Flying Leads



DC Long Flying Leads



QMA RF Connectors

Please feel free to contact us for more information regarding additional options and custom configurations.

Model Number

This guide shows the model numbers for switches by Teledyne Coax Switches. For technical support or custom switches for specific applications, call (800) 351-7368.

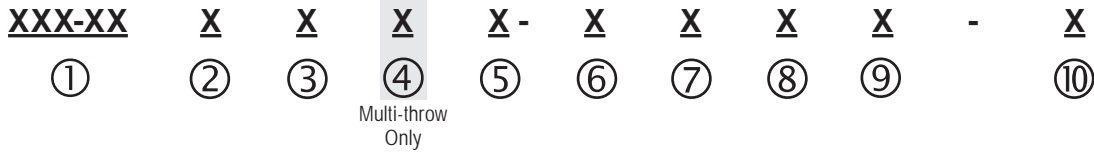

Example: CCR-33S10-T (Commercial SPDT, S=SMA, 28 Vdc, Failsafe, TTL)

All standard switches are RoHS compliant. Contact factory for other options.

①	Switch Model Series Type and Description								
	See tables on pages 2–7 for series name.								
②	Connector Type								
	<table style="width: 100%; border: none;"> <tr> <td style="width: 50%; border: none;">D 7/16 DIN Female</td> <td style="width: 50%; border: none;">N N Female</td> </tr> <tr> <td style="border: none;">K 2.92 mm Female</td> <td style="border: none;">S SMA Female</td> </tr> <tr> <td style="border: none;">M Mini SMB Plug</td> <td style="border: none;">T TNC Female</td> </tr> </table>	D 7/16 DIN Female	N N Female	K 2.92 mm Female	S SMA Female	M Mini SMB Plug	T TNC Female		
D 7/16 DIN Female	N N Female								
K 2.92 mm Female	S SMA Female								
M Mini SMB Plug	T TNC Female								
③	Actuator Voltage								
	<table style="width: 100%; border: none;"> <tr> <td style="width: 50%; border: none;">1 28 Vdc – Failsafe (Normally Open if single-pole multi-throw)</td> <td style="width: 50%; border: none;">6 28 Vdc – Latching*</td> </tr> <tr> <td style="border: none;">2 15 Vdc – Failsafe (Normally Open if single-pole multi-throw)</td> <td style="border: none;">7 15 Vdc – Latching*</td> </tr> <tr> <td style="border: none;">3 12 Vdc – Failsafe (Normally Open if single-pole multi-throw)</td> <td style="border: none;">8 12 Vdc – Latching*</td> </tr> <tr> <td style="border: none;">4 24 Vdc – Failsafe (Normally Open if single-pole multi-throw)</td> <td style="border: none;">9 24 Vdc – Latching*</td> </tr> </table>	1 28 Vdc – Failsafe (Normally Open if single-pole multi-throw)	6 28 Vdc – Latching*	2 15 Vdc – Failsafe (Normally Open if single-pole multi-throw)	7 15 Vdc – Latching*	3 12 Vdc – Failsafe (Normally Open if single-pole multi-throw)	8 12 Vdc – Latching*	4 24 Vdc – Failsafe (Normally Open if single-pole multi-throw)	9 24 Vdc – Latching*
1 28 Vdc – Failsafe (Normally Open if single-pole multi-throw)	6 28 Vdc – Latching*								
2 15 Vdc – Failsafe (Normally Open if single-pole multi-throw)	7 15 Vdc – Latching*								
3 12 Vdc – Failsafe (Normally Open if single-pole multi-throw)	8 12 Vdc – Latching*								
4 24 Vdc – Failsafe (Normally Open if single-pole multi-throw)	9 24 Vdc – Latching*								
④	Number Positions for Multi-throw								
	3, 4, 5, 6, 7, 8, 9, 0=10 Indicates number of positions on multi-throw switches (skip this number if not single-pole multi-throw)								
⑤	Actuator Type								
	<table style="width: 100%; border: none;"> <tr> <td style="width: 50%; border: none;">O No self-cutoff or indicator contacts</td> <td style="width: 50%; border: none;">D Self cutoff only</td> </tr> <tr> <td style="border: none;">C Indicator contacts only</td> <td style="border: none;">E Self cutoff and indicator contacts</td> </tr> </table>	O No self-cutoff or indicator contacts	D Self cutoff only	C Indicator contacts only	E Self cutoff and indicator contacts				
O No self-cutoff or indicator contacts	D Self cutoff only								
C Indicator contacts only	E Self cutoff and indicator contacts								
⑥	TTL Driver								
	<table style="width: 100%; border: none;"> <tr> <td style="width: 50%; border: none;">T TTL driver with diodes</td> <td style="width: 50%; border: none;">TD Decoders and TTL driver with diodes</td> </tr> </table>	T TTL driver with diodes	TD Decoders and TTL driver with diodes						
T TTL driver with diodes	TD Decoders and TTL driver with diodes								
⑦	Polarity								
	R Positive (+) Common. Option not available with T and TD options.								
⑧	Narrow Body and/or Moisture Seal								
	<table style="width: 100%; border: none;"> <tr> <td style="width: 50%; border: none;">N Narrow Body (SPDT switch only)</td> <td style="width: 50%; border: none;">M Moisture Seal</td> </tr> </table>	N Narrow Body (SPDT switch only)	M Moisture Seal						
N Narrow Body (SPDT switch only)	M Moisture Seal								
⑨	Coil Transient Suppression and/or Sub-D Connector								
	<table style="width: 100%; border: none;"> <tr> <td style="width: 50%; border: none;">D Coil Transient Suppression Diode & Polarity Protection Diode</td> <td style="width: 50%; border: none;">S Sub-D Connector</td> </tr> </table>	D Coil Transient Suppression Diode & Polarity Protection Diode	S Sub-D Connector						
D Coil Transient Suppression Diode & Polarity Protection Diode	S Sub-D Connector								
⑩	Custom Part Number								
	Assigned by Engineering								

*Polarity sensitive **Note: Normally Open terminated switches are polarity sensitive**

Space-qualified and custom switches available. Please contact factory for more information.

Teledyne Coax Switch Matrix



Teledyne Switch Matrices are available with a variety of RF connector types:

- SMA
- QMA
- 2.92 mm
- mini-SMB (75Ω)
- TNC
- BNC (50Ω or 75Ω)
- N

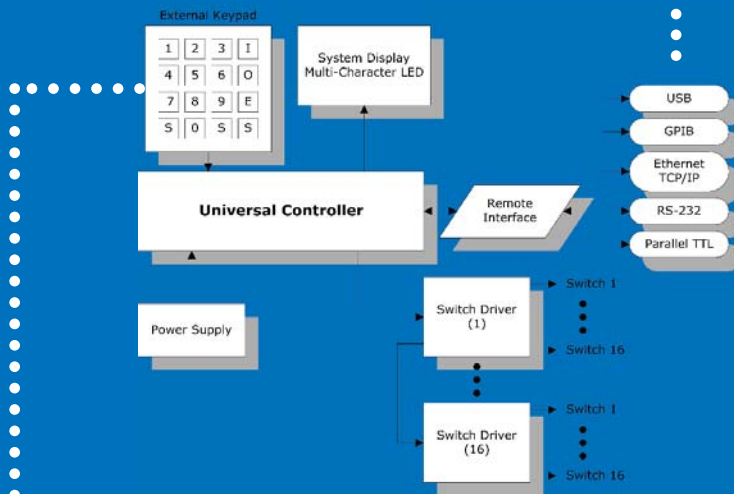

• Custom Enclosures to suit any size, mounting configuration or environmental conditions, are available.

Teledyne Switch Matrices also come in:
Standard 19" Rack Mount Chassis

**Model shown is a 4U chassis. Height depends on total number of switches. Other chassis heights available upon request. (1U = 1.75" Height)*



Teledyne Switch Matrices

Feature:

- Relay Switch Position Indicators
- Switch Cycle Count

CCR-33/CR-33, CCR-53/CR-53, CCR-33K, CCR-40K

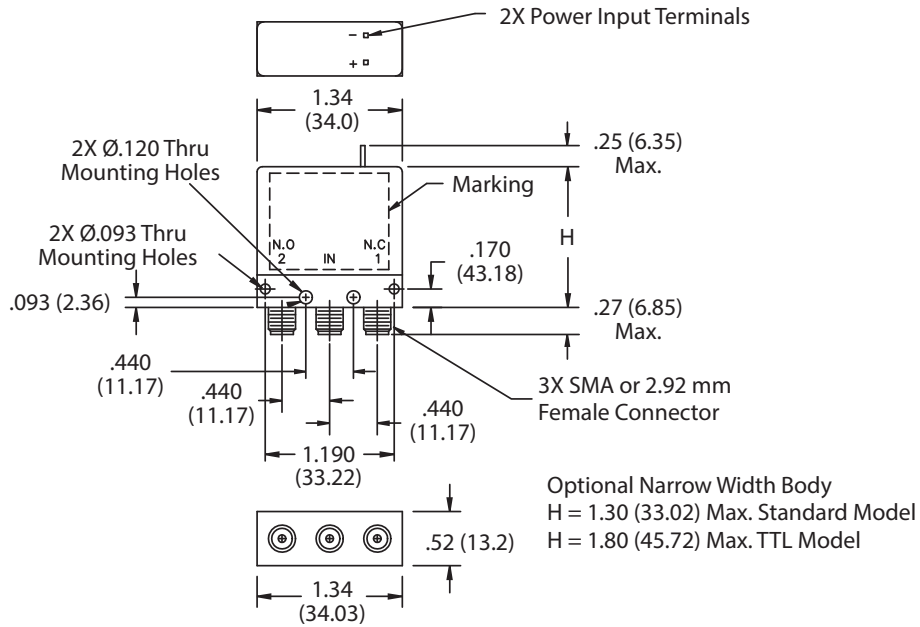
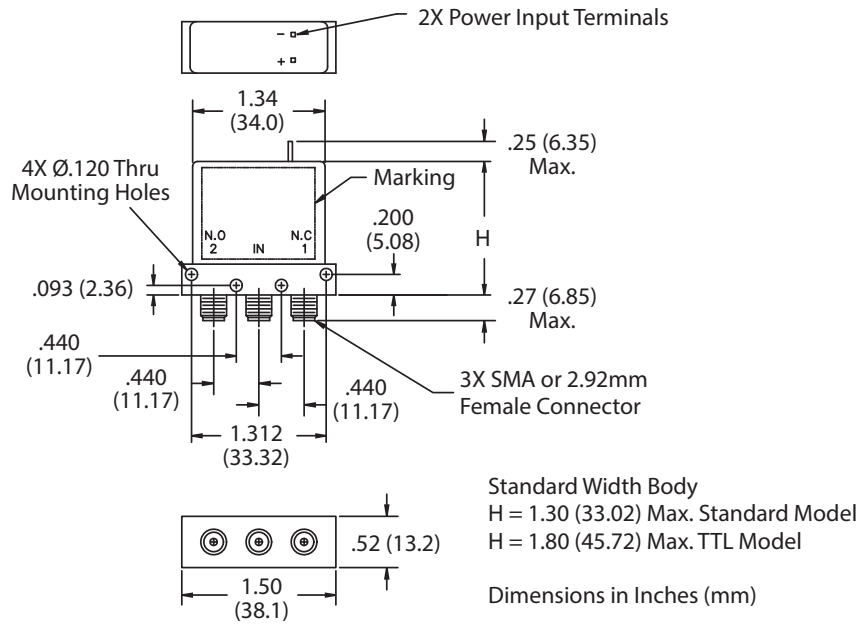

CCR-33/CR-33

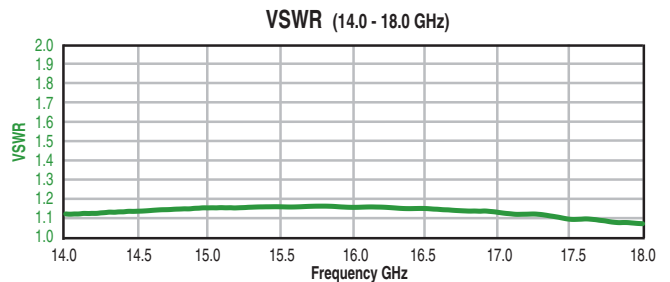
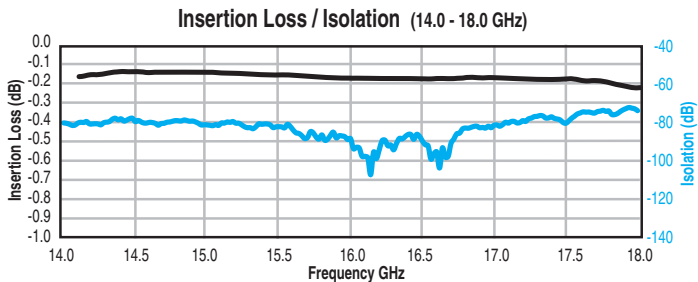
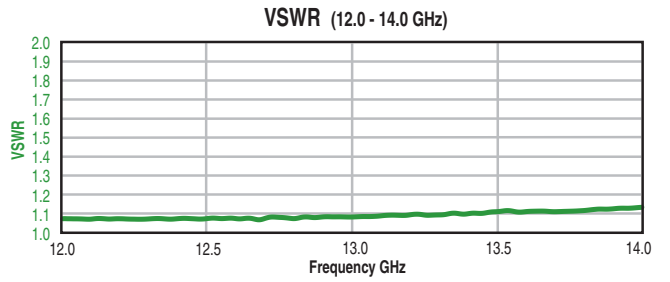
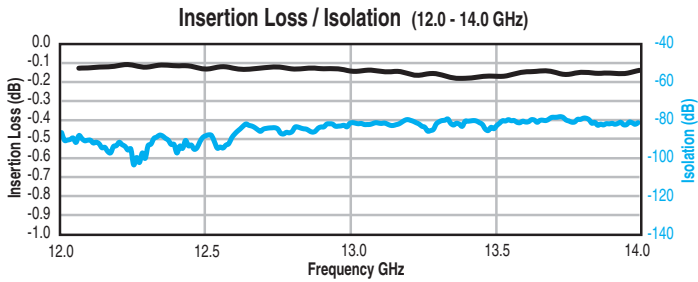
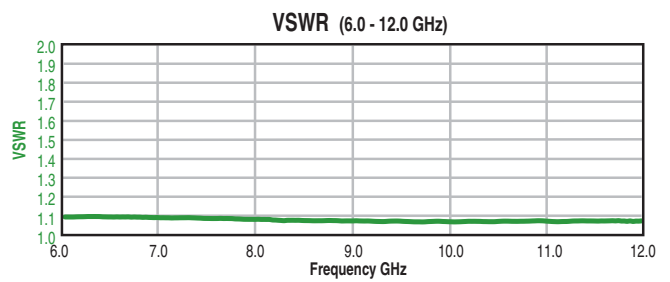
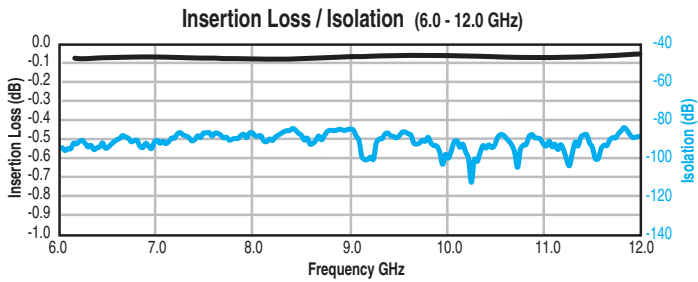
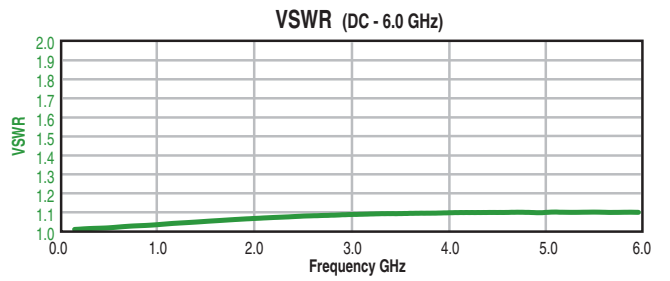
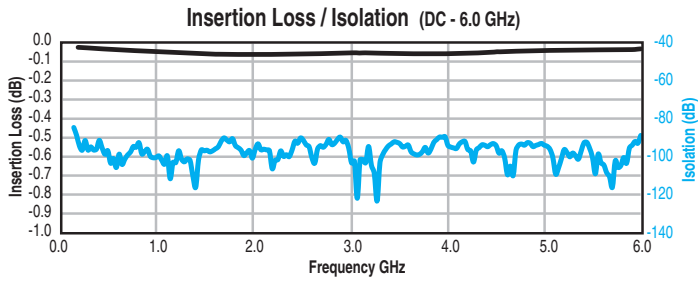

CCR-53/CR-53

SPDT SWITCHES

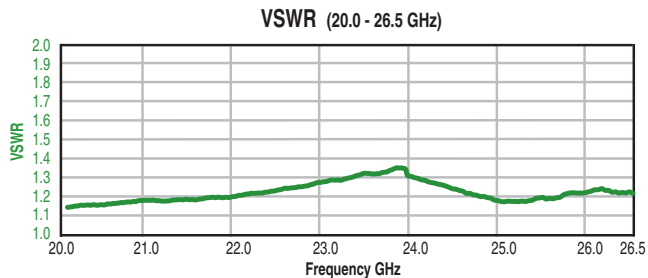
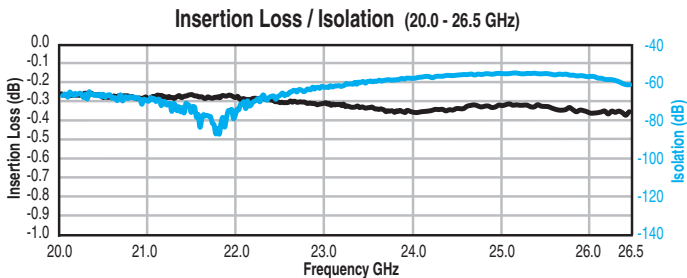
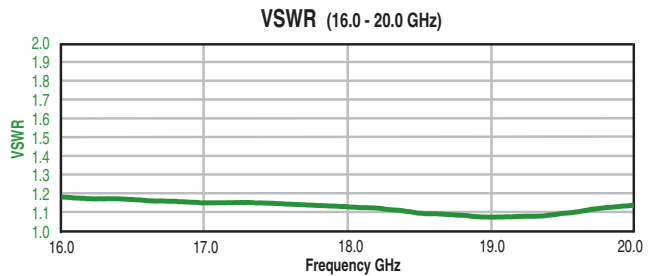
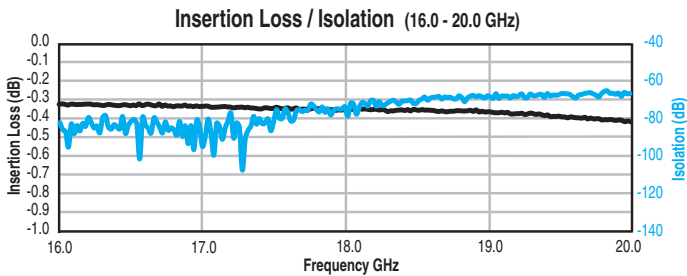
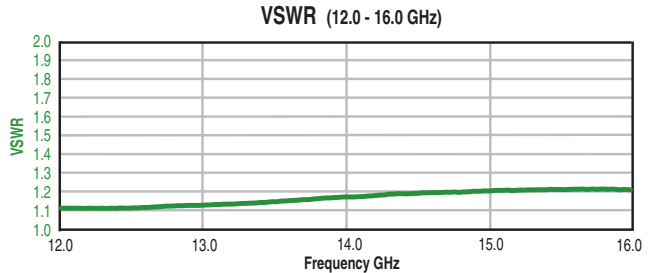
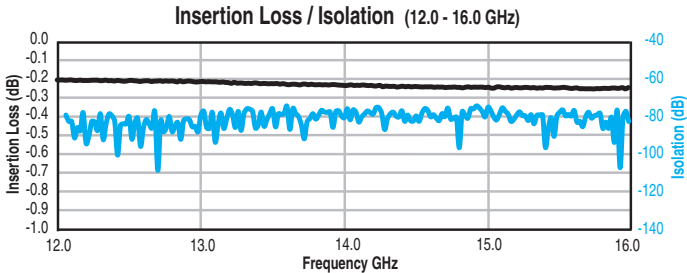
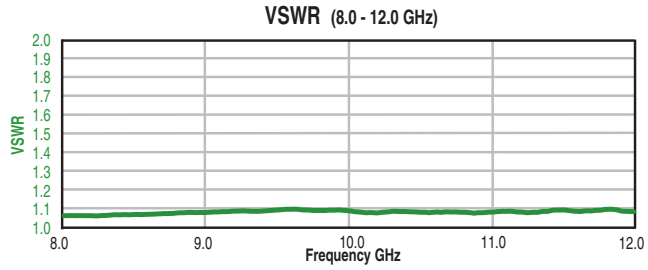
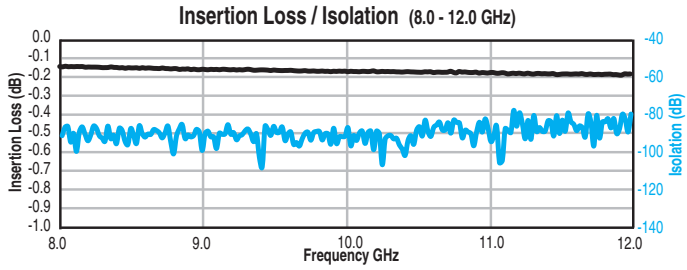
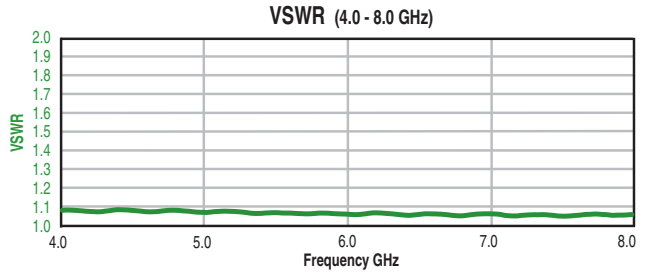
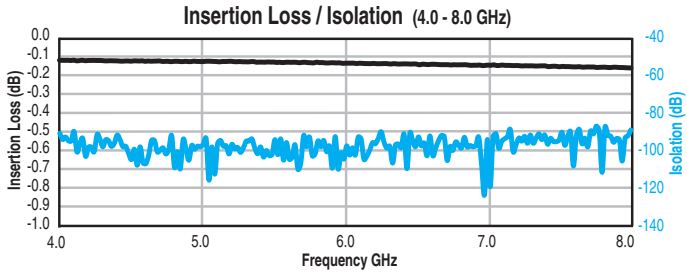
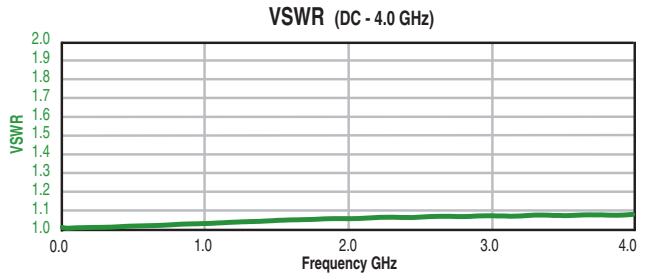
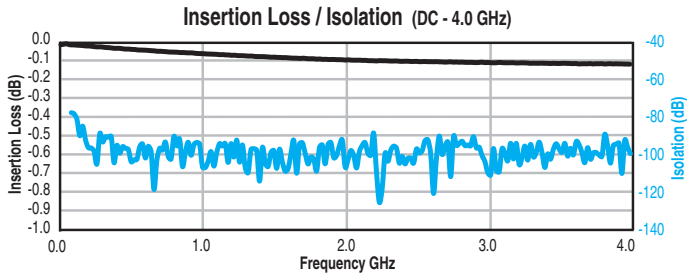

CCR-33K

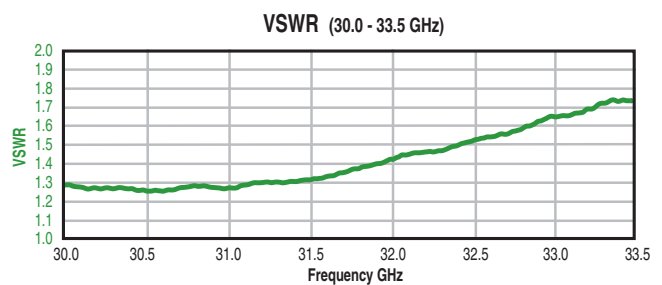
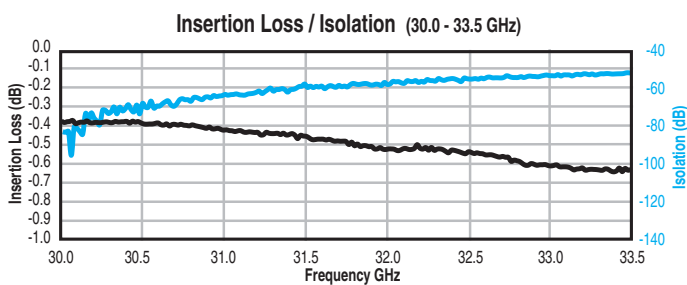
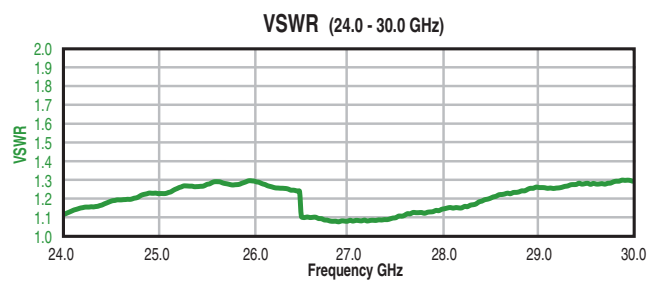
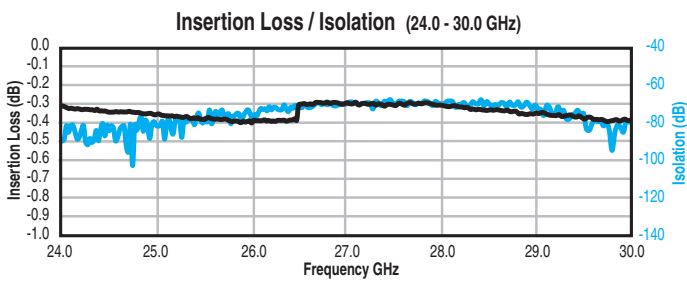
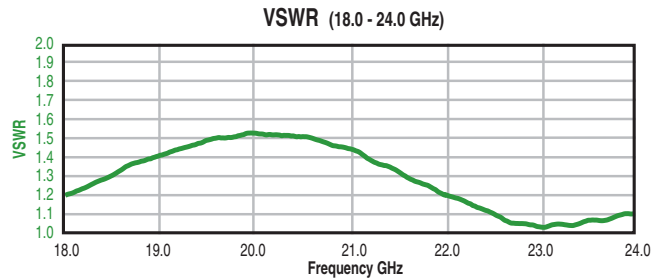
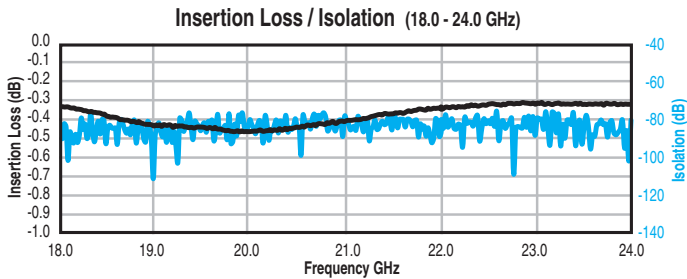
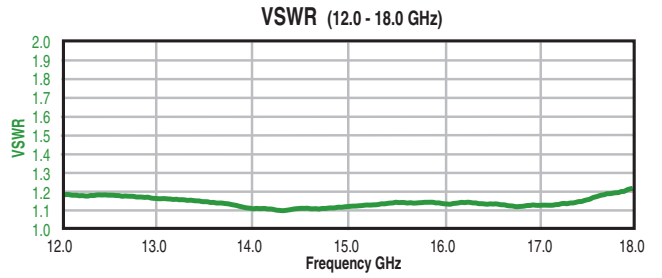
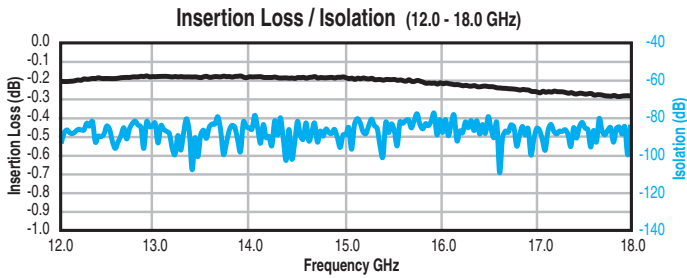
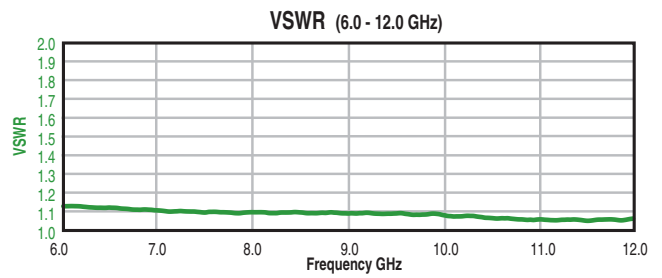
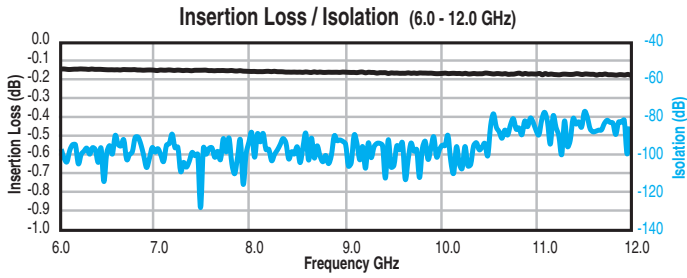
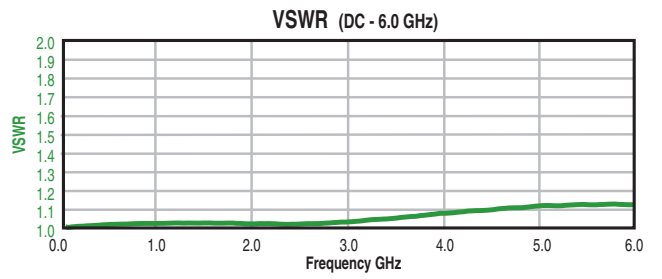
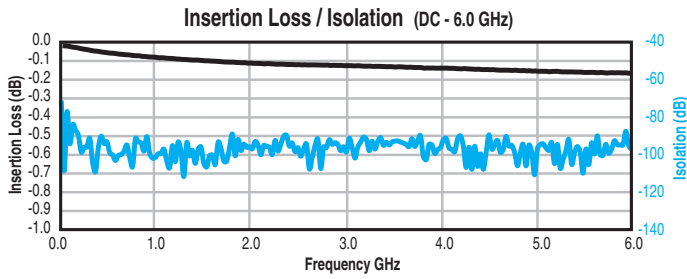

CCRT-33/CRT-33, CCRT-53/CRT-53

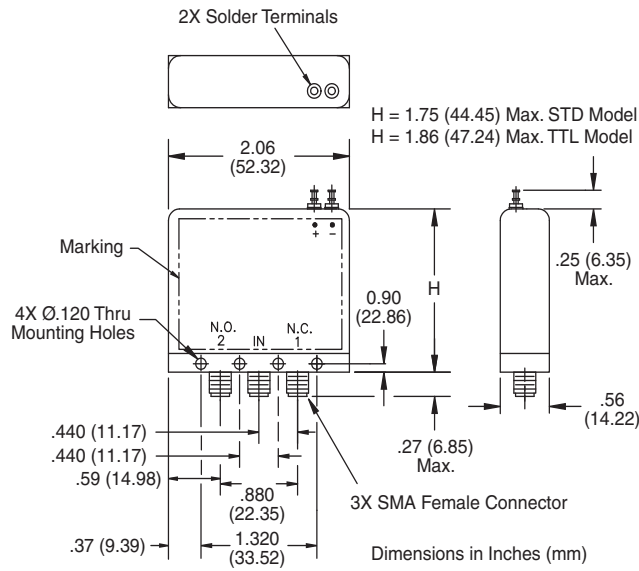

CCRT-33/CRT-33

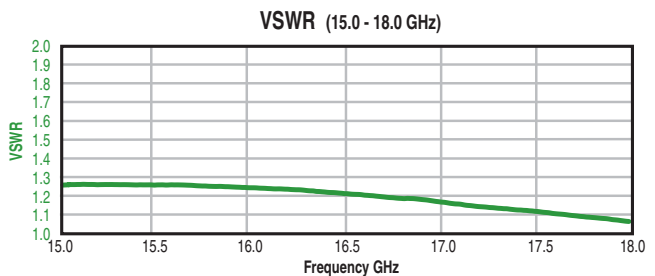
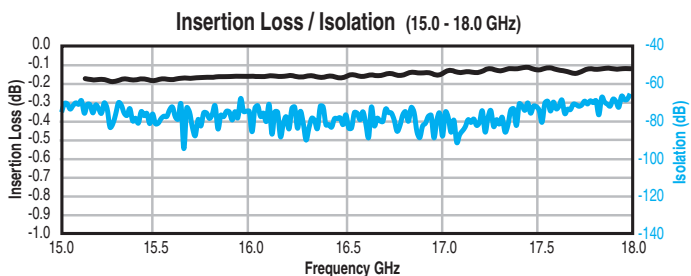
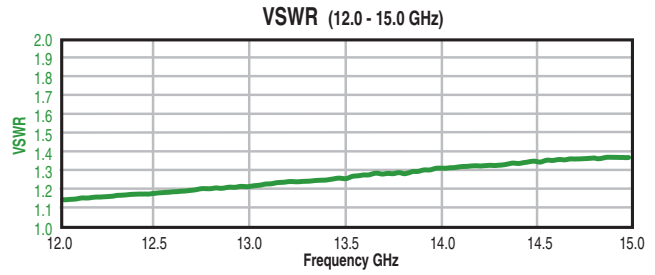
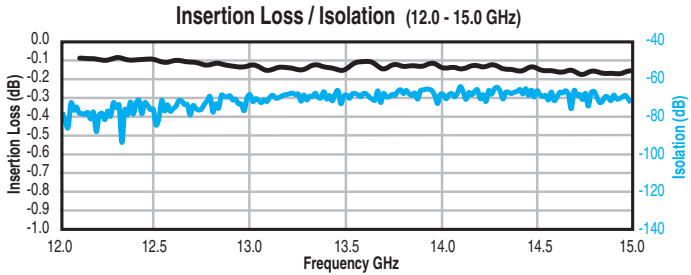
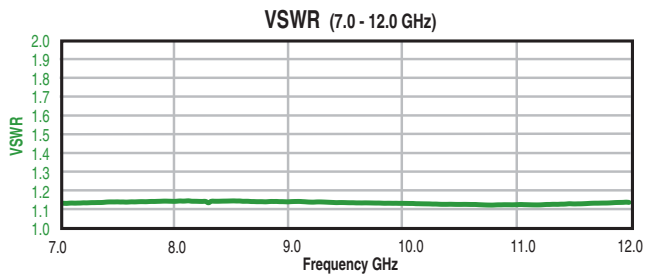
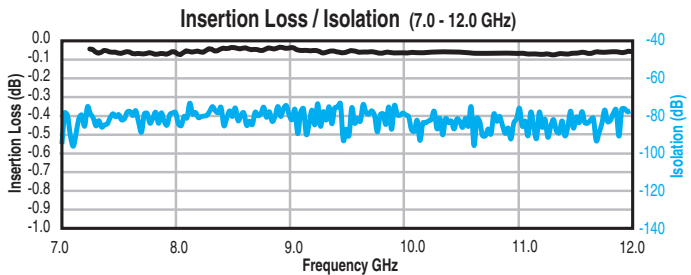
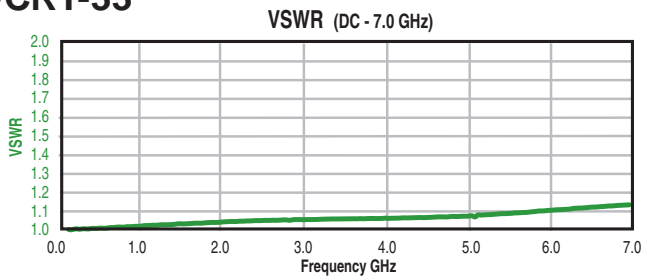
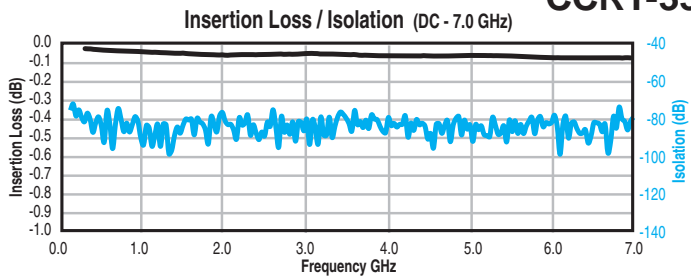

CCRT-53/CRT-53

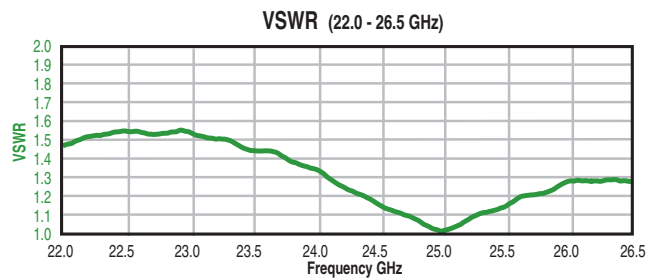
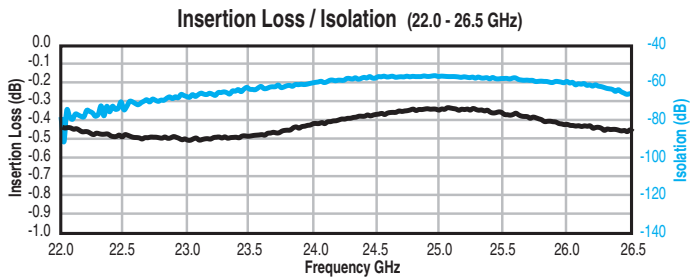
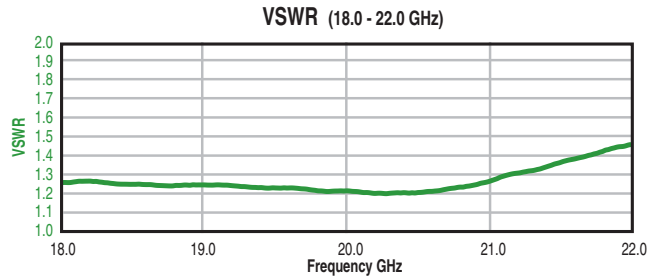
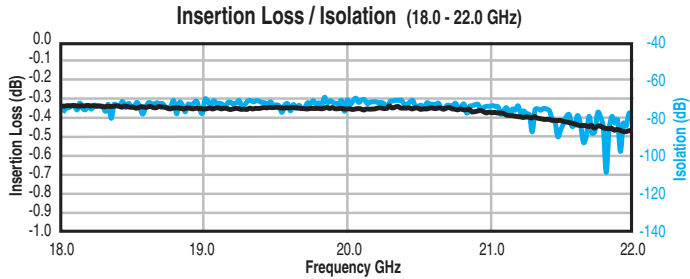
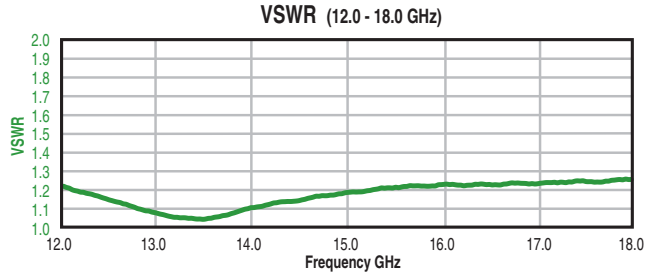
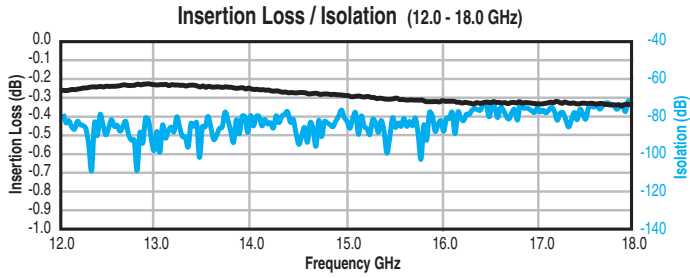
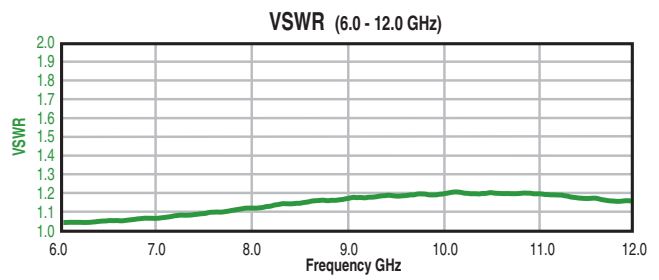
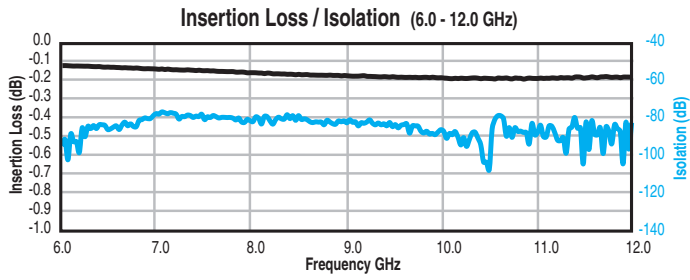
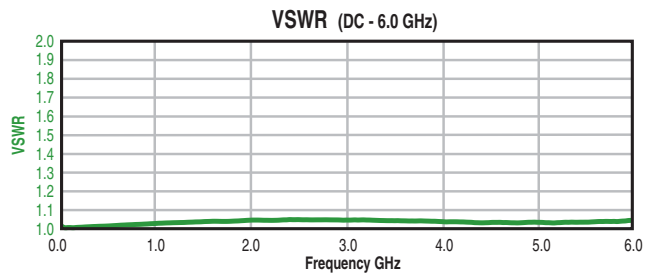
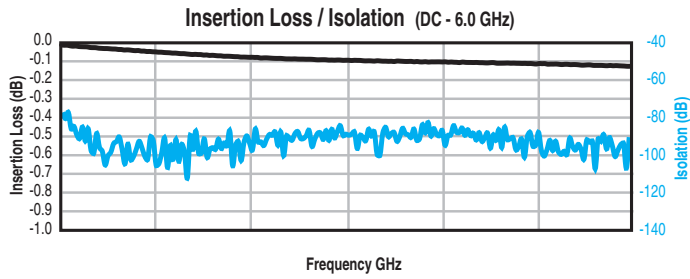

CCR-33M

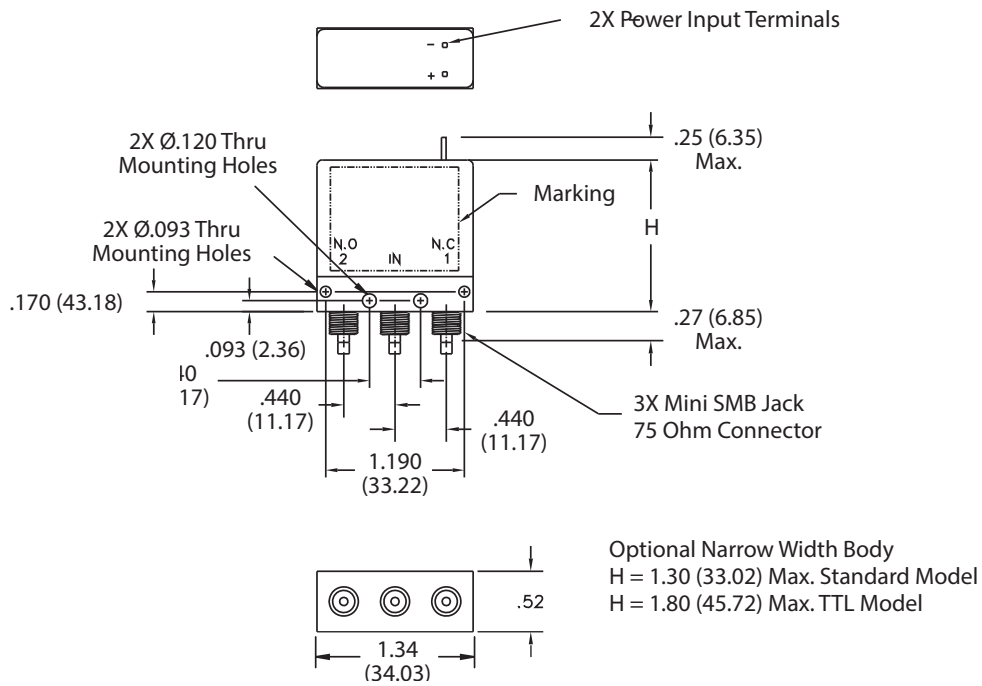
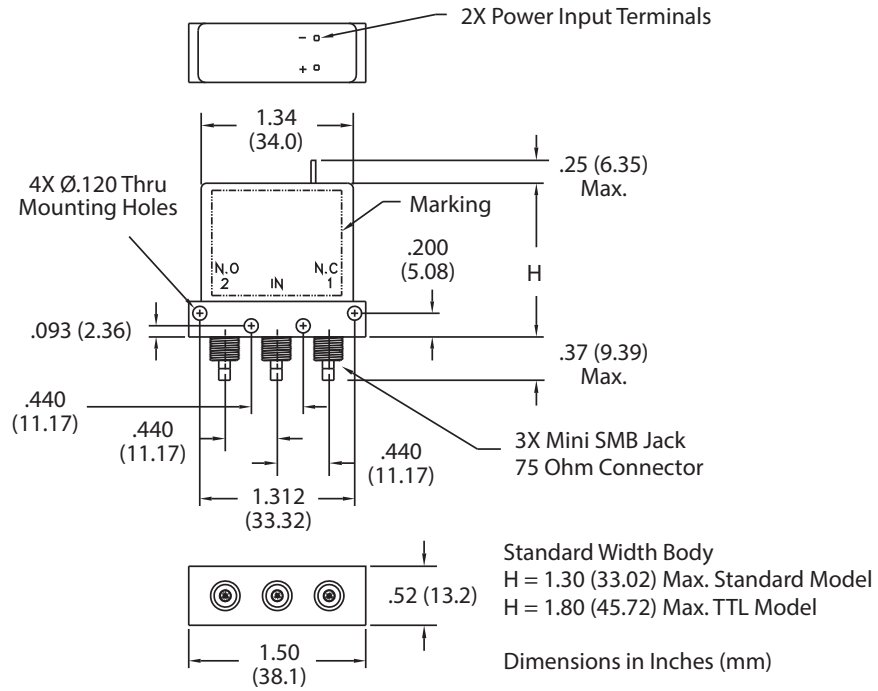

CCR-33M

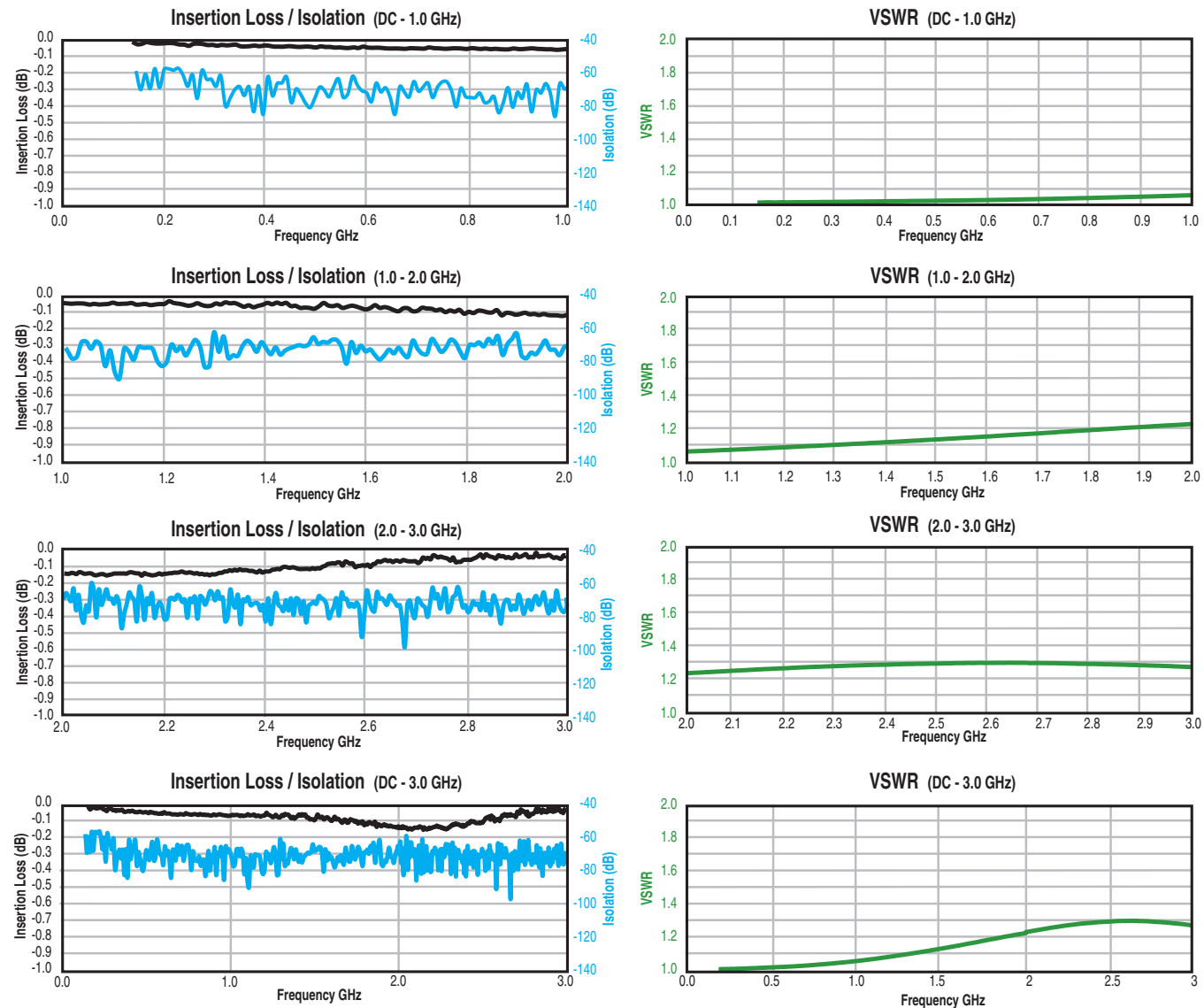

SPDT SWITCHES

CCS-32/CS-32

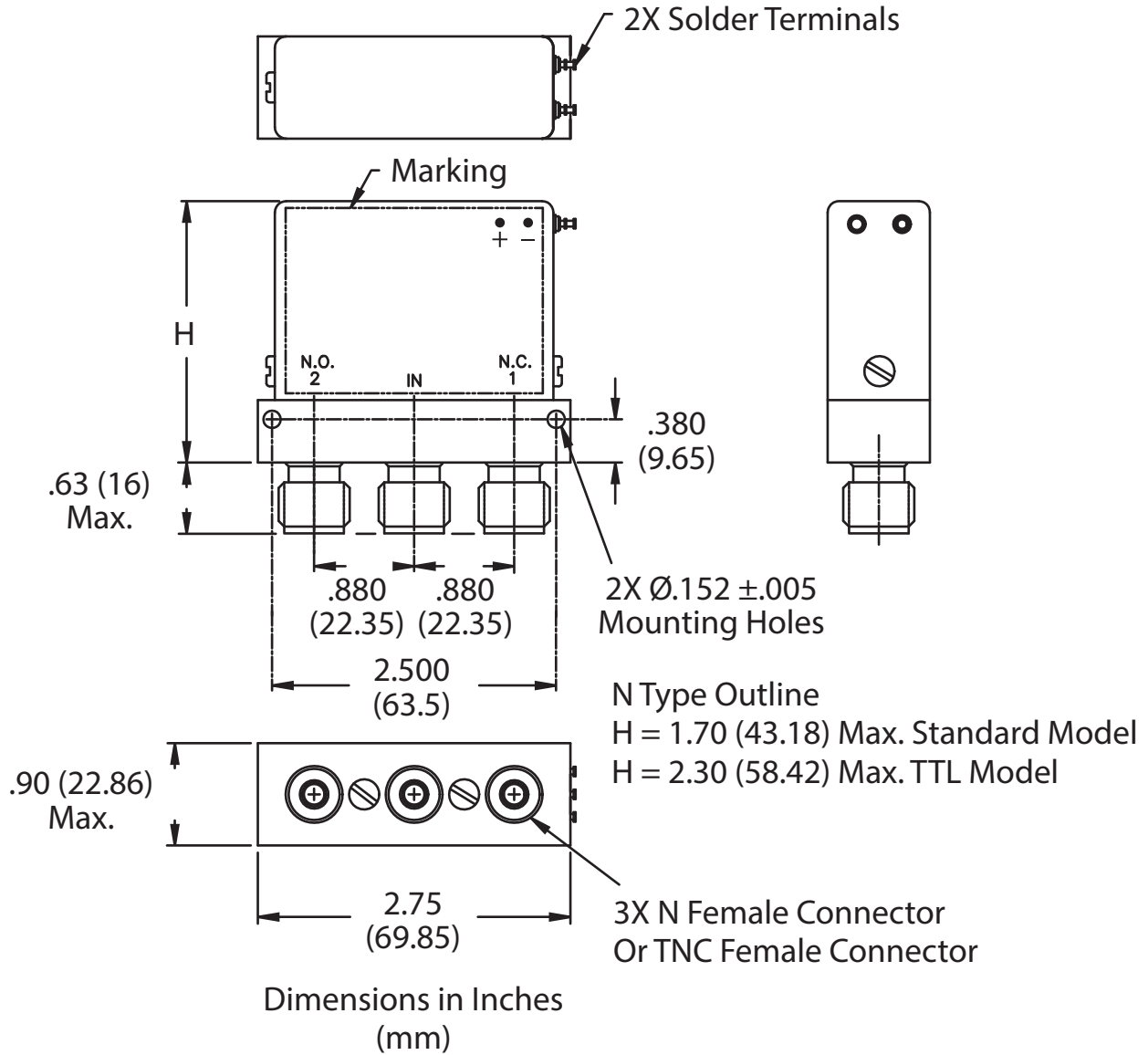

CCS-32/CS-32

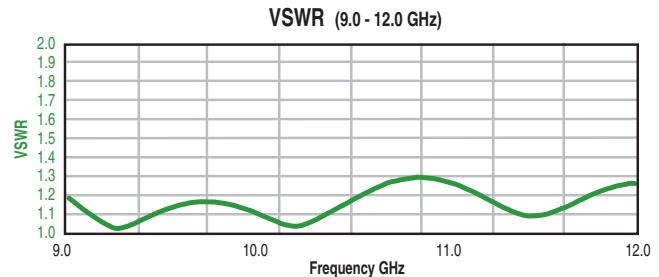
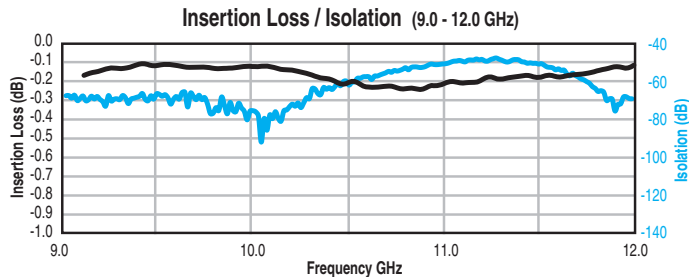
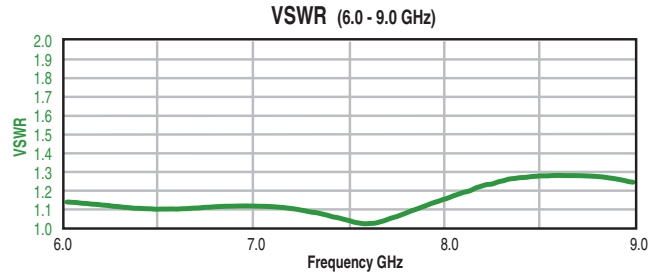
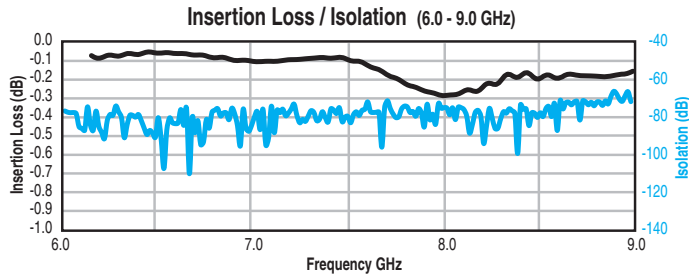
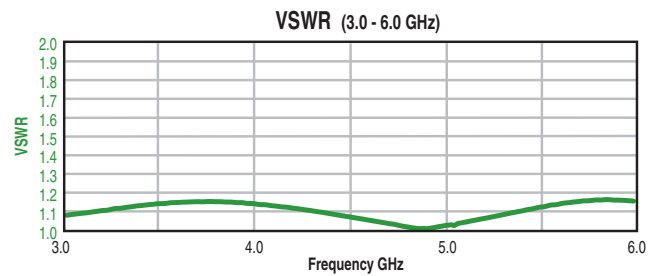
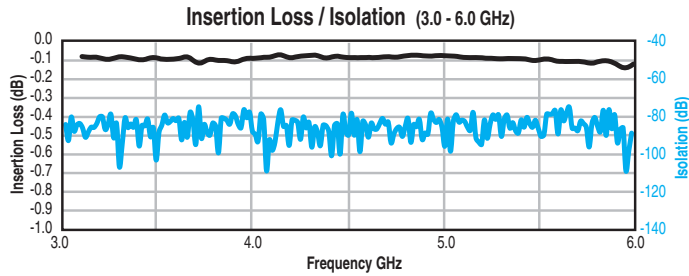
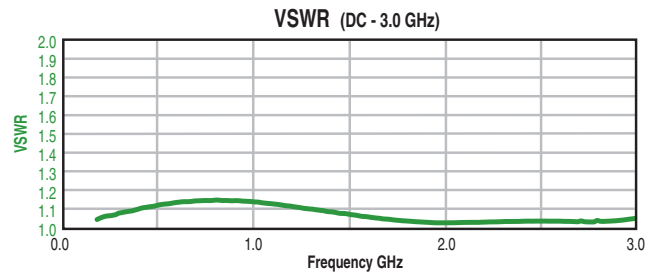
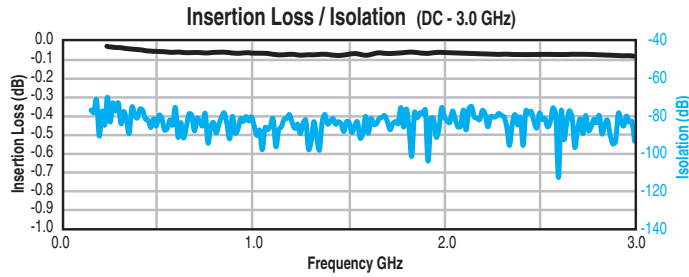

CCRS-33/CRS-33, CCRS-53/CRS-53

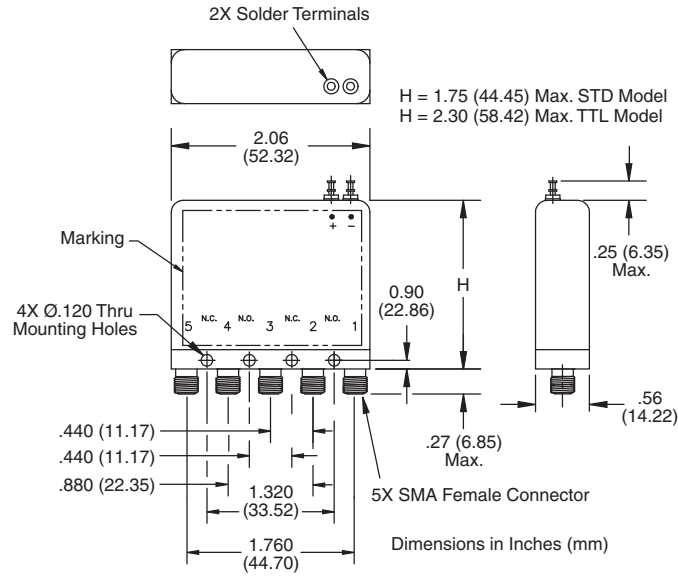

CCRS-33/CRS-33

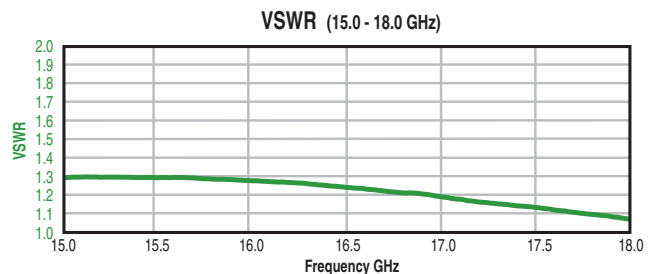
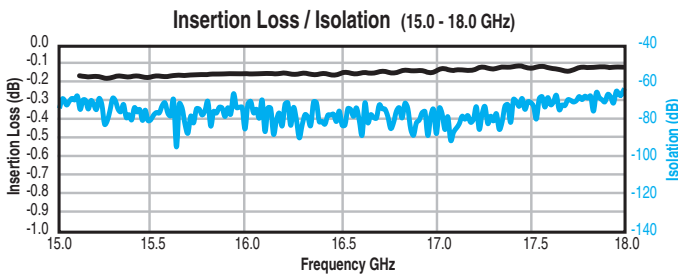
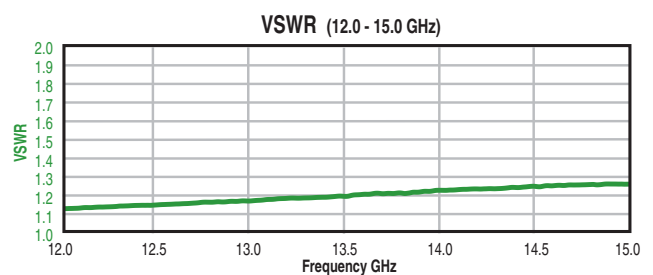
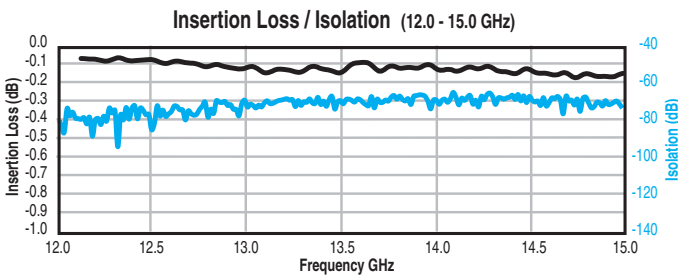
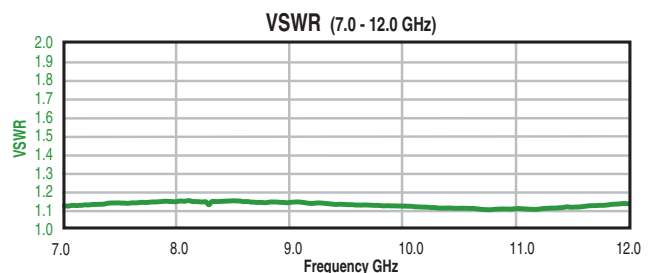
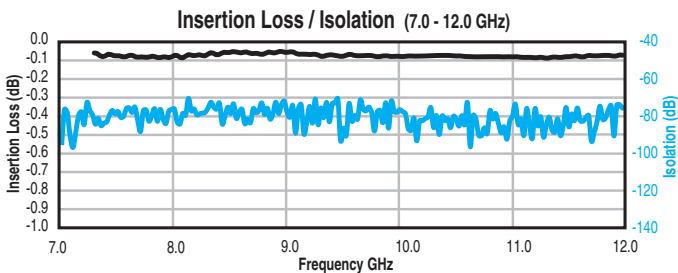
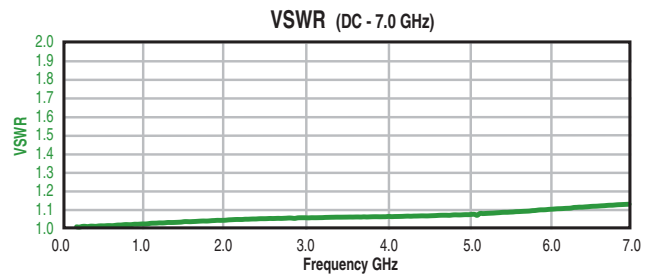
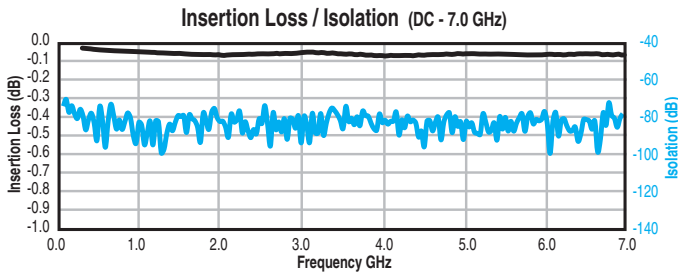

CCRS-53/CRS-53

2P3T SWITCHES

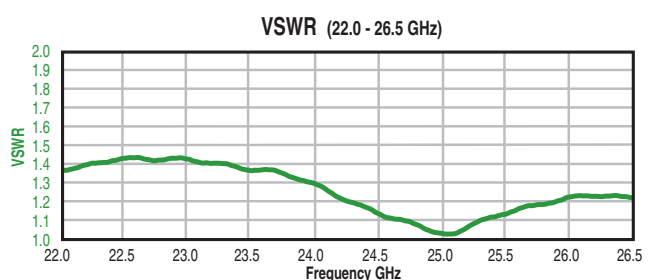
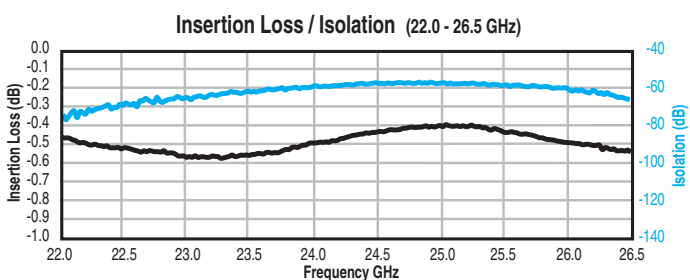
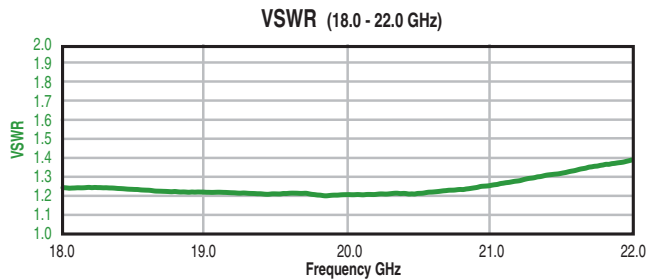
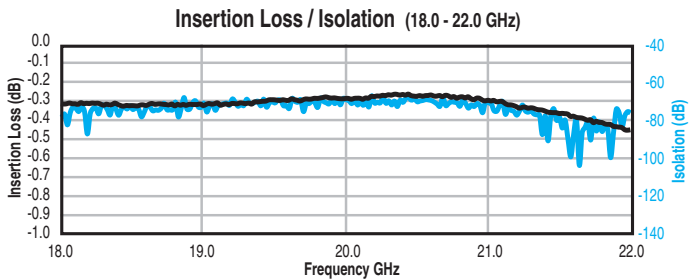
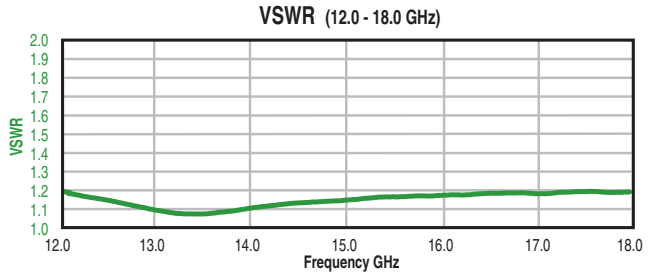
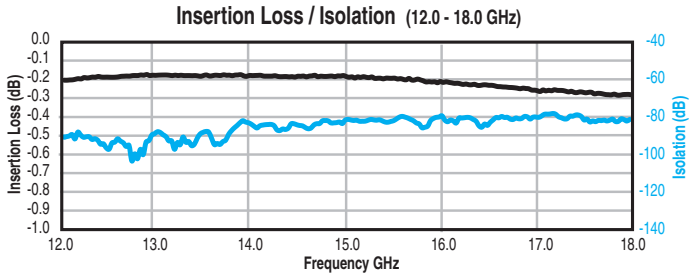
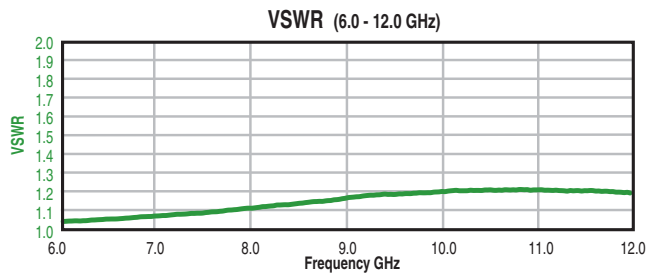
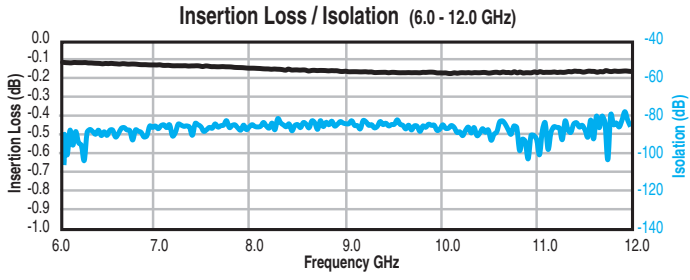
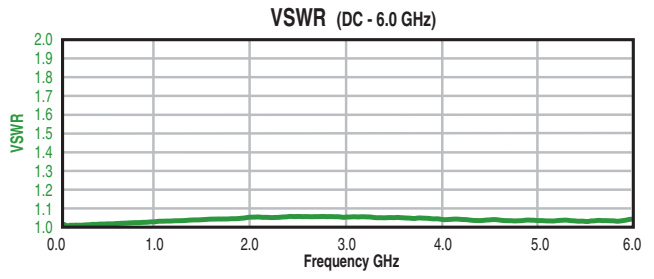
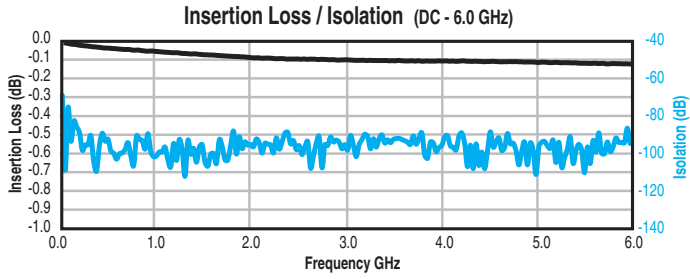

CCS-37/CS-37

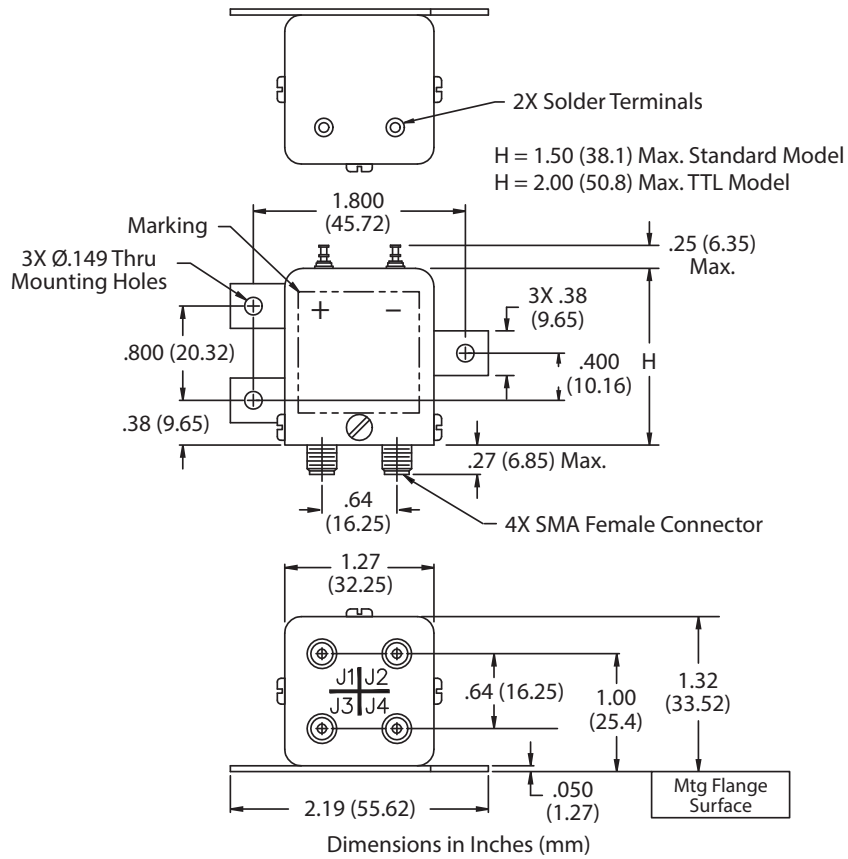

CCS-37/CS-37

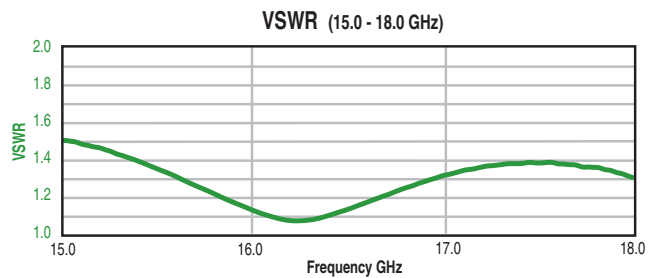
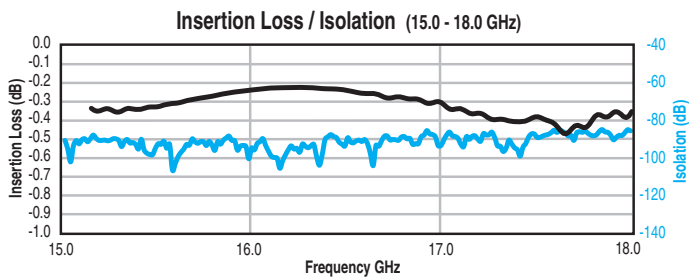
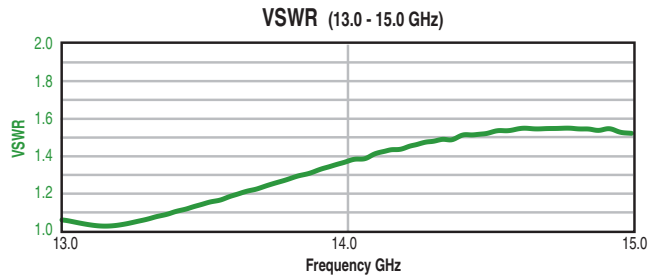
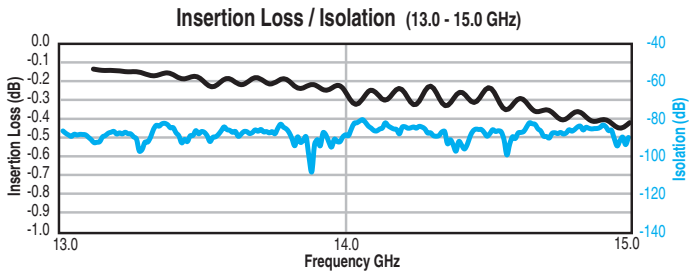
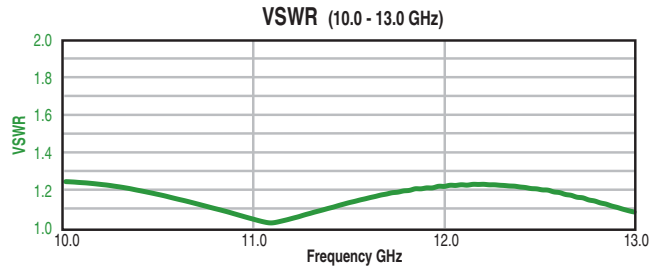
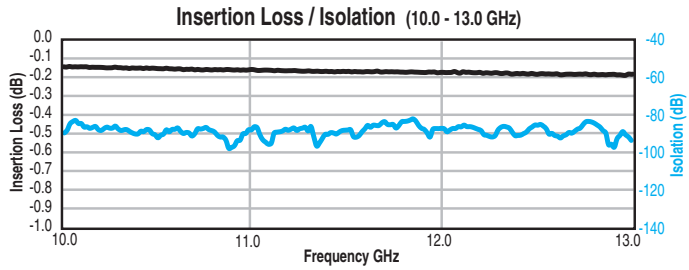
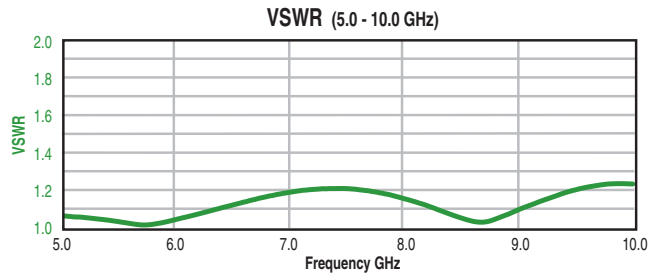
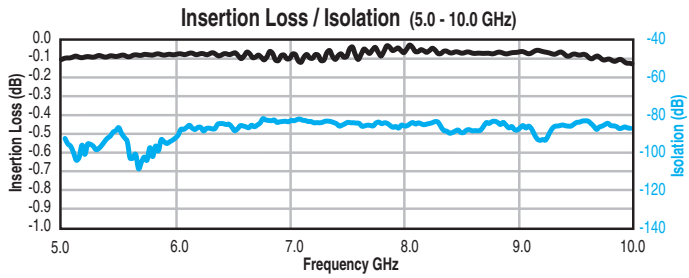
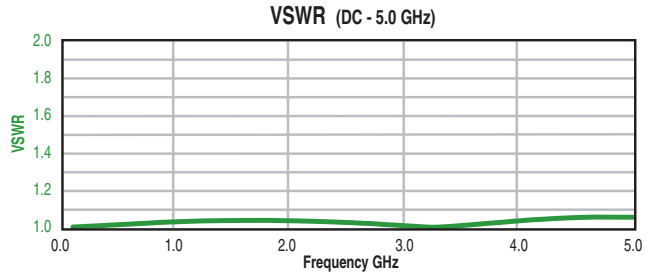
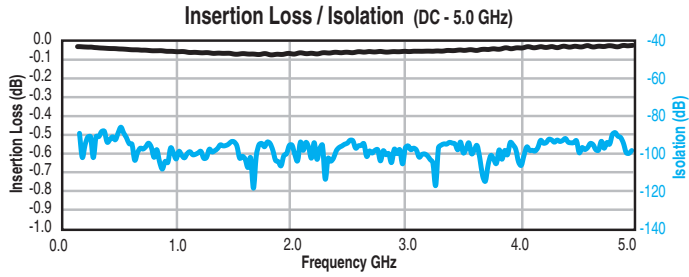

CCS-47/CS-47

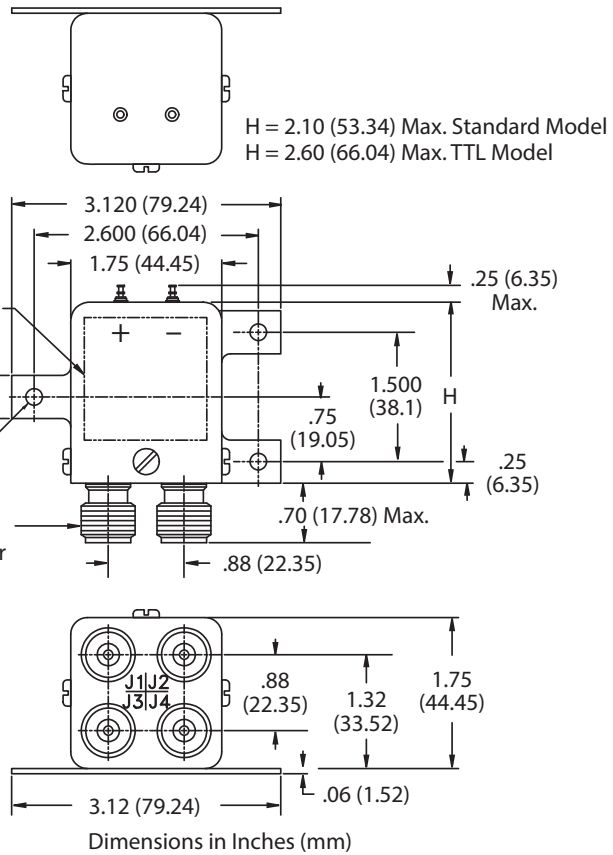

TRANSFER SWITCHES

CCS-47/CS-47

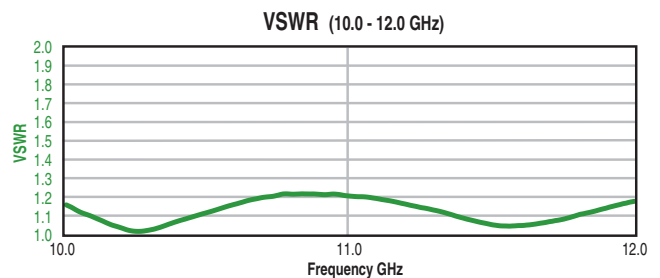
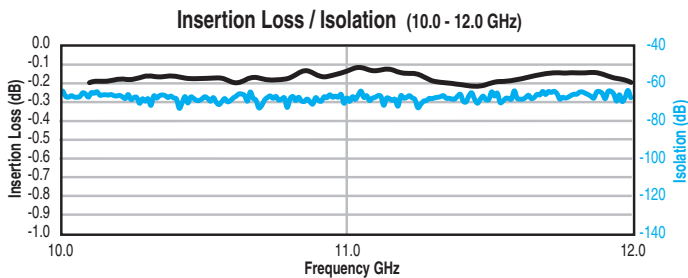
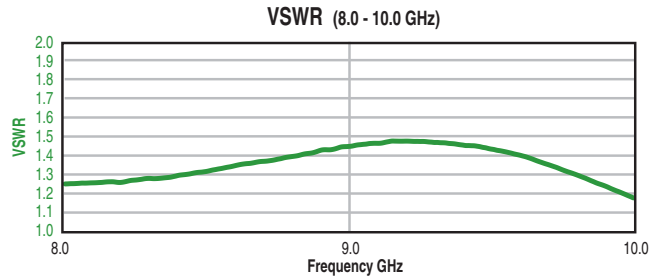
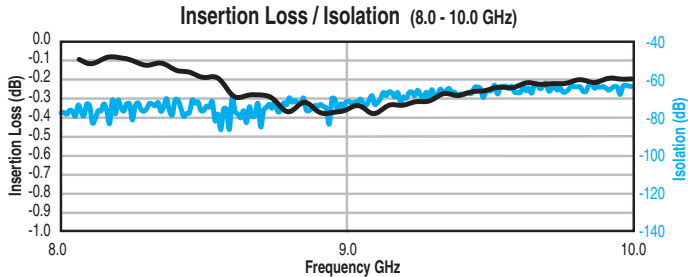
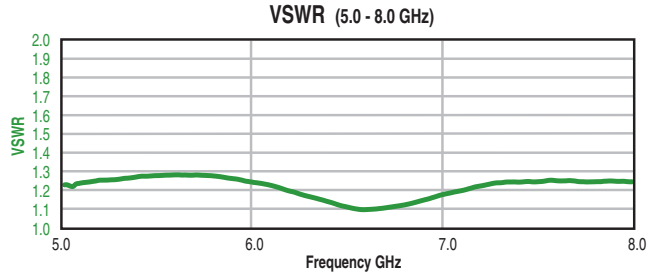
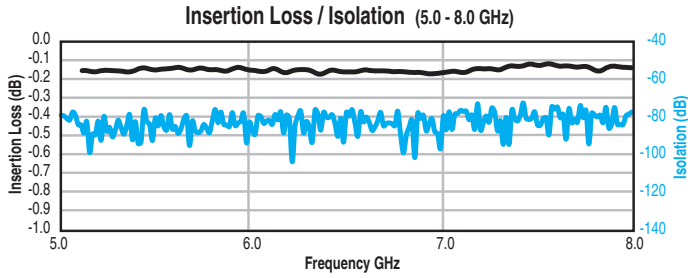
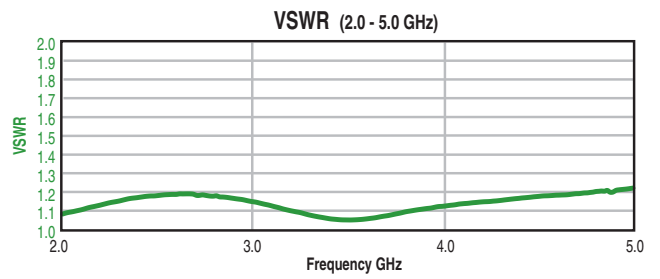
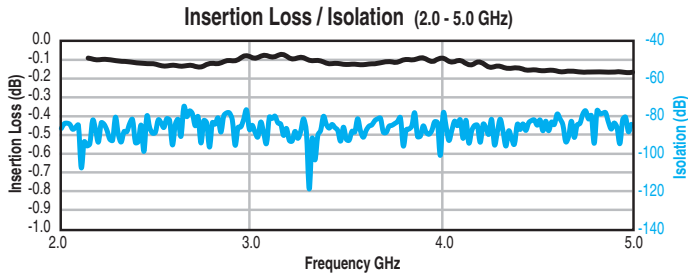
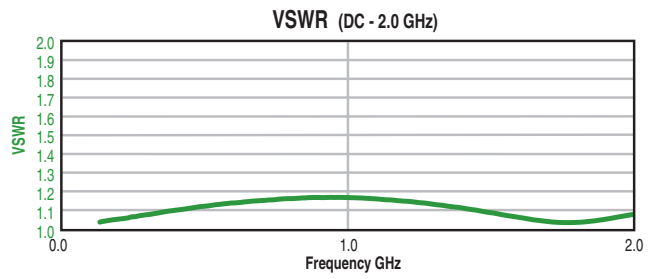
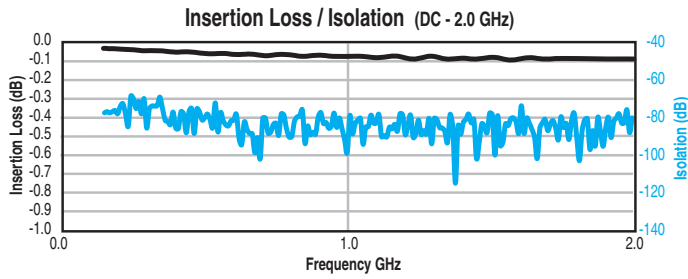

TRANSFER SWITCHES

CCR-38/CR-38, CCR-58/CR-58

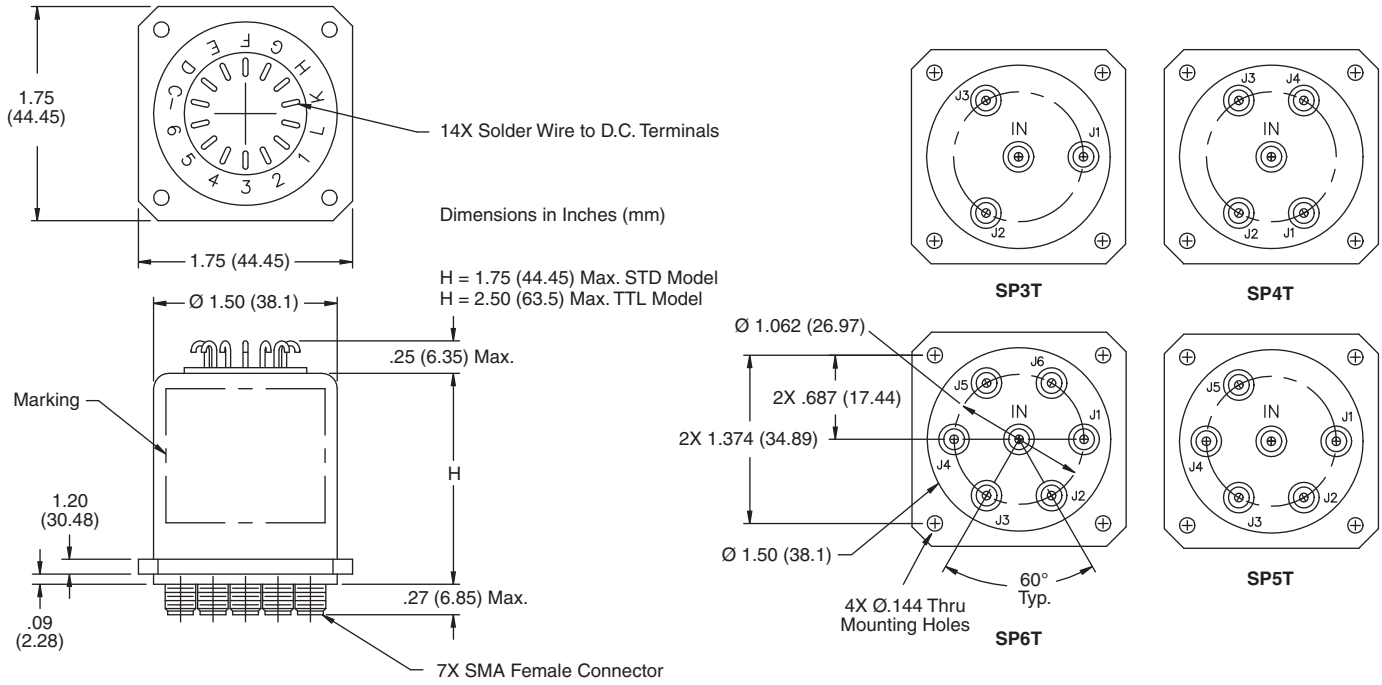

CCT-38/CT-38, CCT-58/CT-58, CCR-39/CR-39, CCT-39/CT-39, CCR-59/CR-59, CCT-59/CT-59

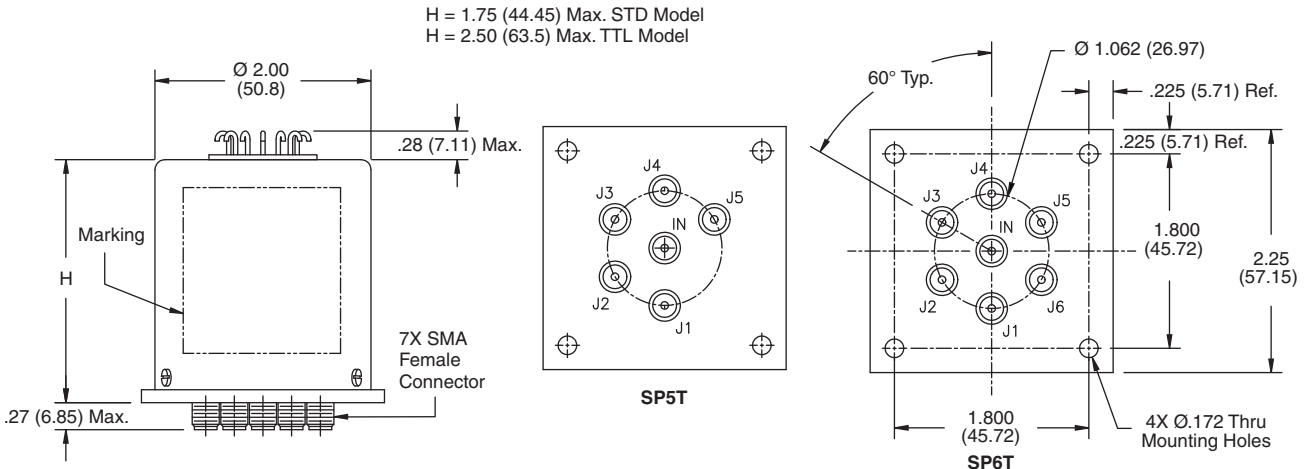
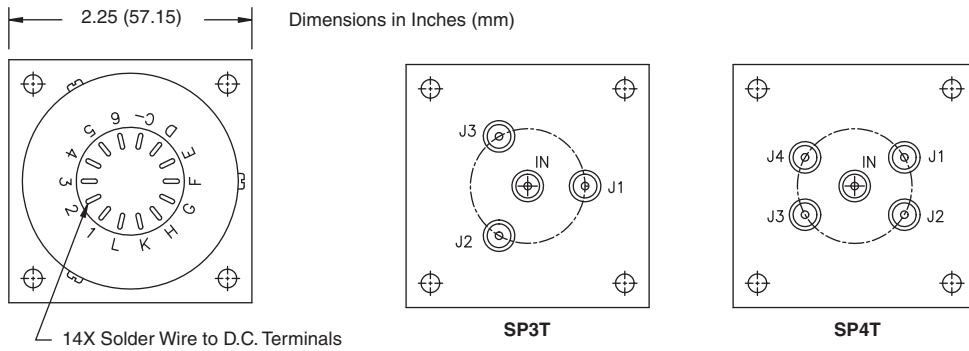

MULTI-THROW SWITCHES

CCR-38/CR-38, CCR-58/CR-58, CCR-39/CR-39, CCR-59/CR-59, CCT-38/CT-38, CCT-58/CT-58, CCT-39/CT-39, CCT-59/CT-59

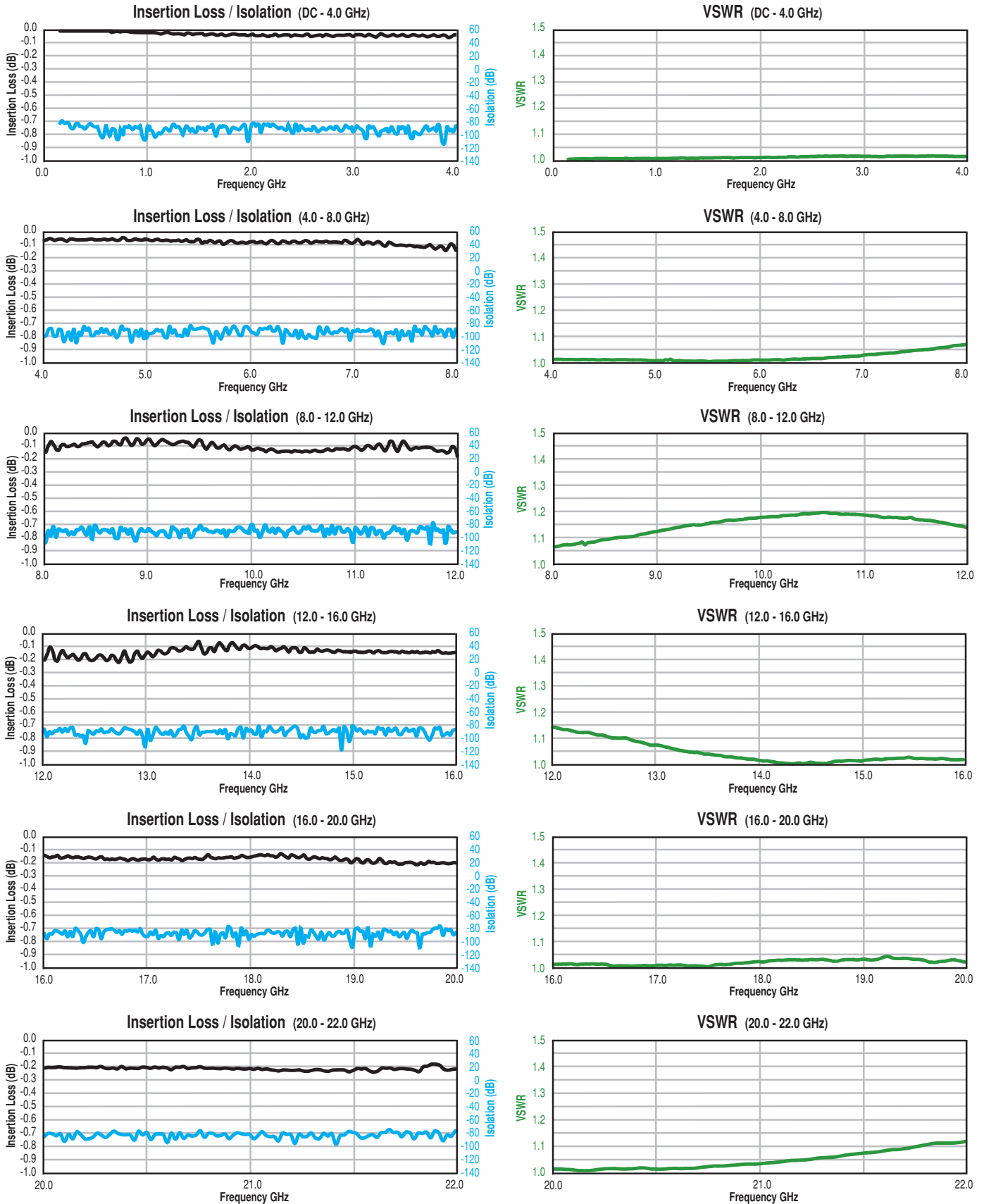

MULTI-THROW SWITCHES

CCR-38, CCT-38 SP8-10T

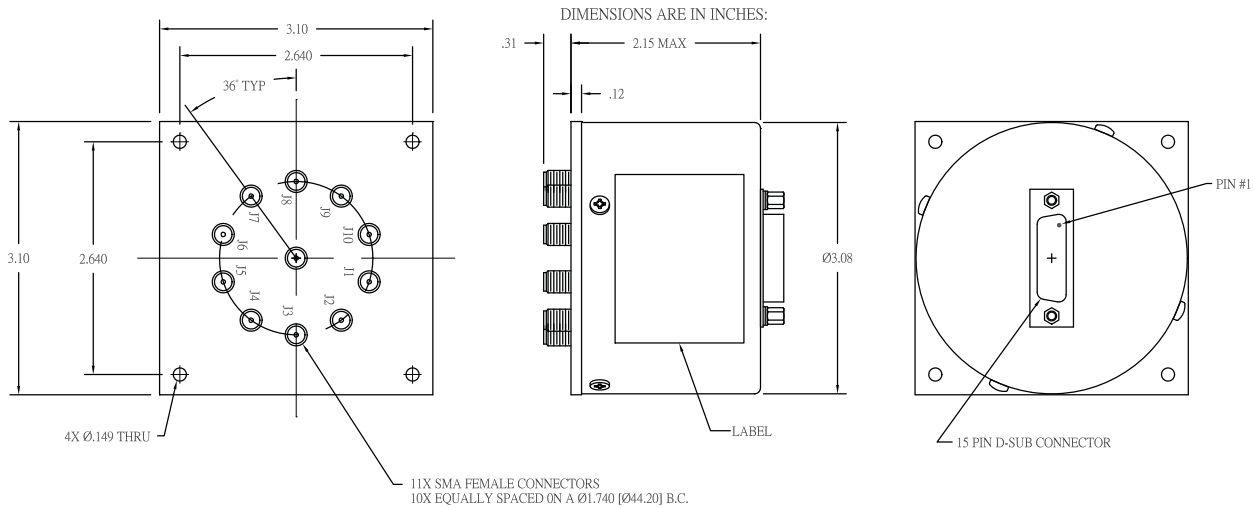
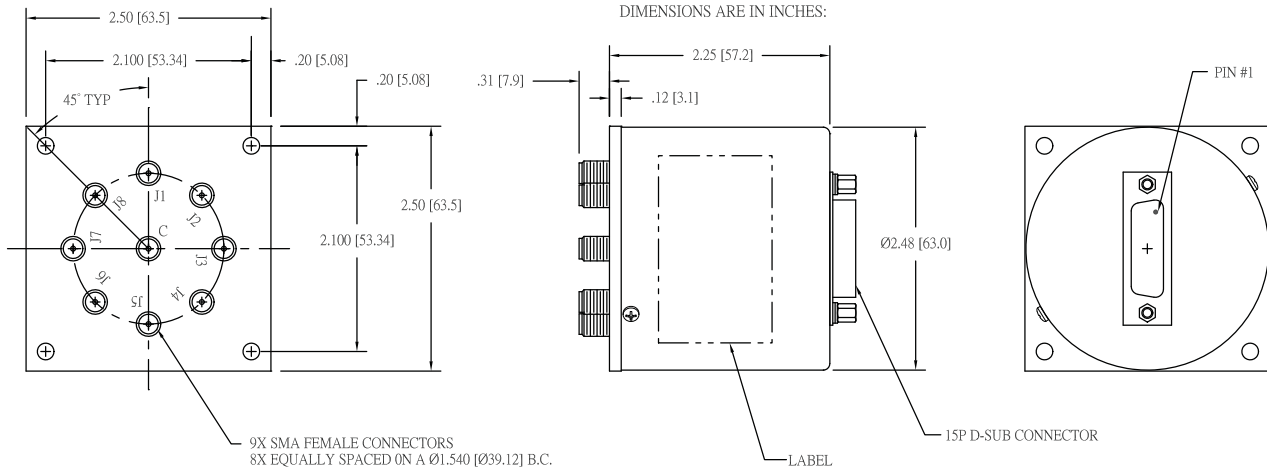

MULTI-THROW SWITCHES

SP7T & SP8T RF Performance

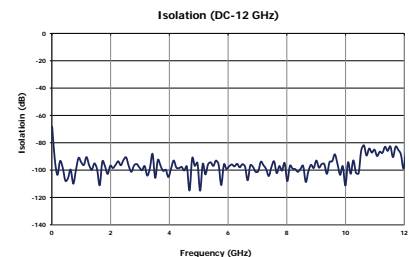
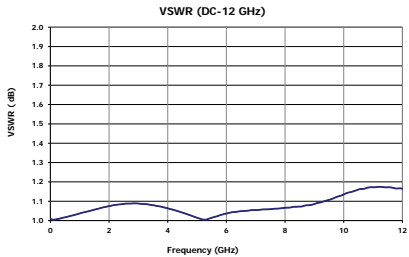
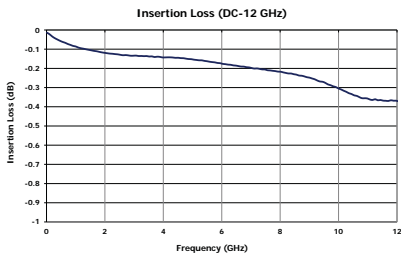

SP9T & SP10T RF Performance

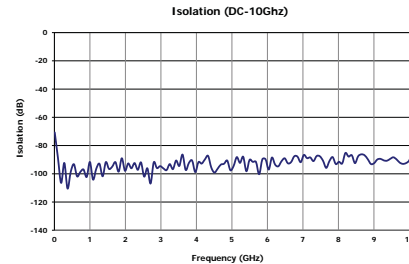
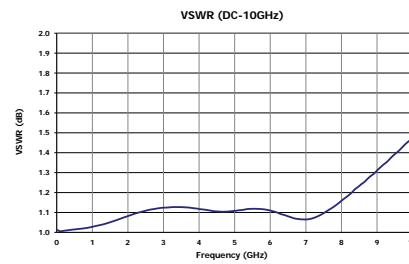
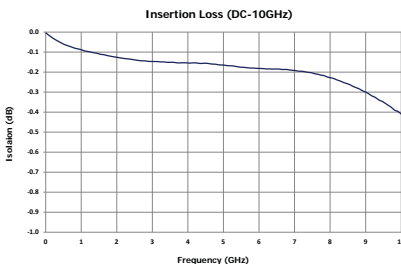

CCR-39, CCT-39 SP8-10T

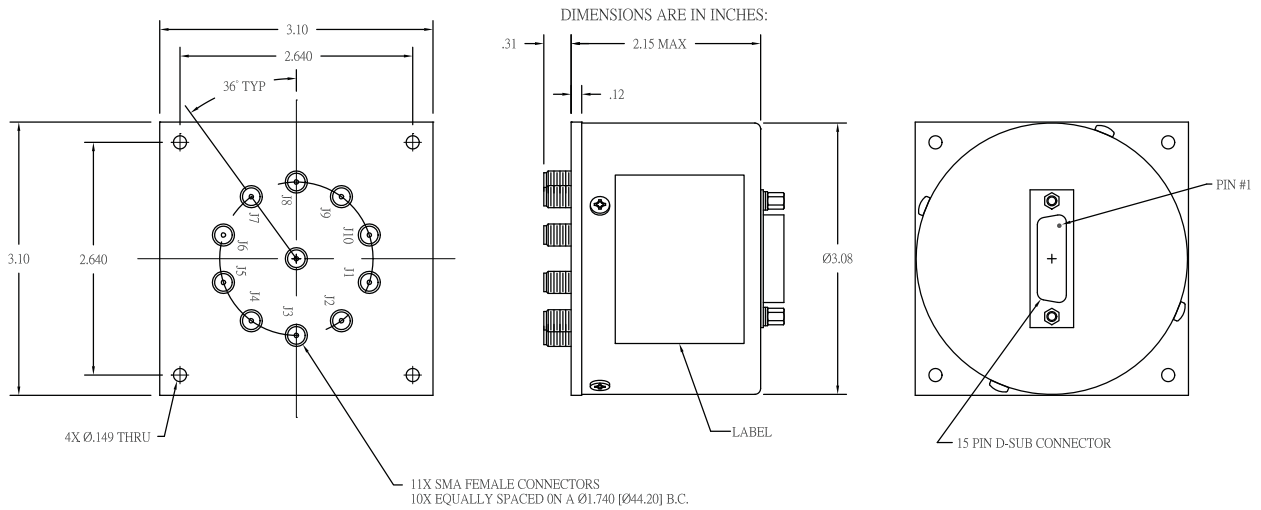
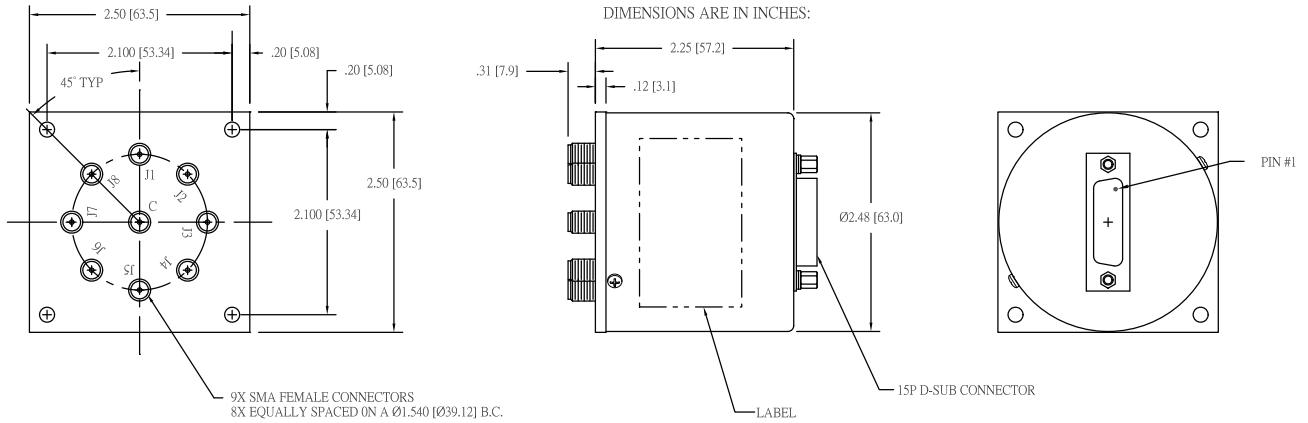

SP7T & SP8T RF Performance

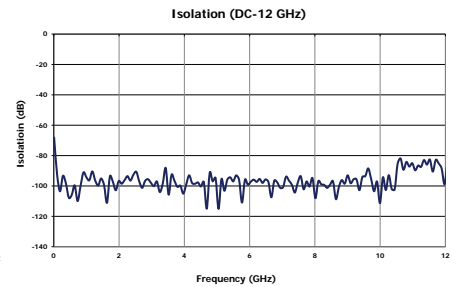
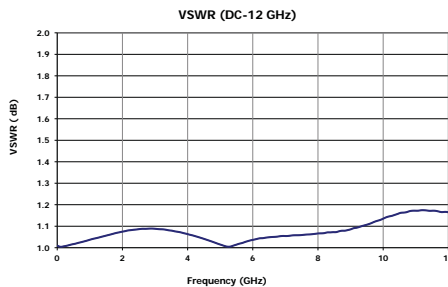
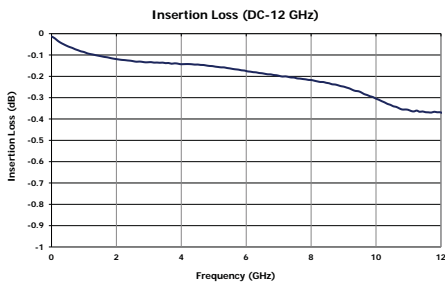

SP9T & SP10T RF Performance

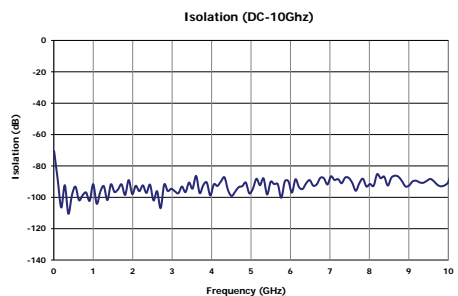
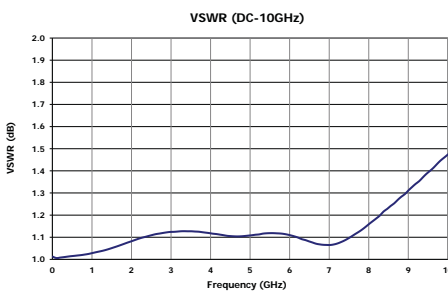
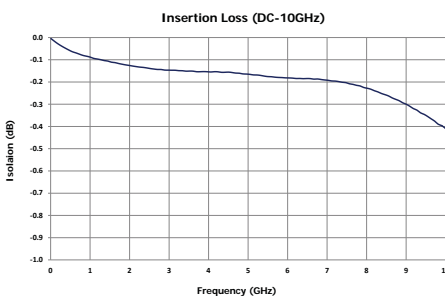

CCS-18/CS-18

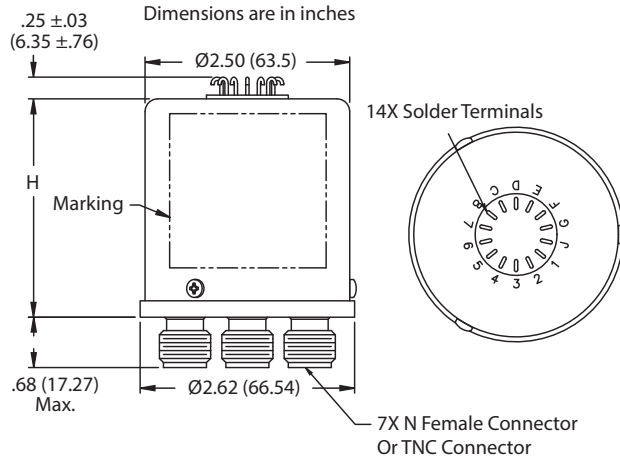

H = 2.15 (54.61) Max. Standard Model
 H = 2.65 (67.31) Max. TTL Model

MULTI-THROW SWITCHES

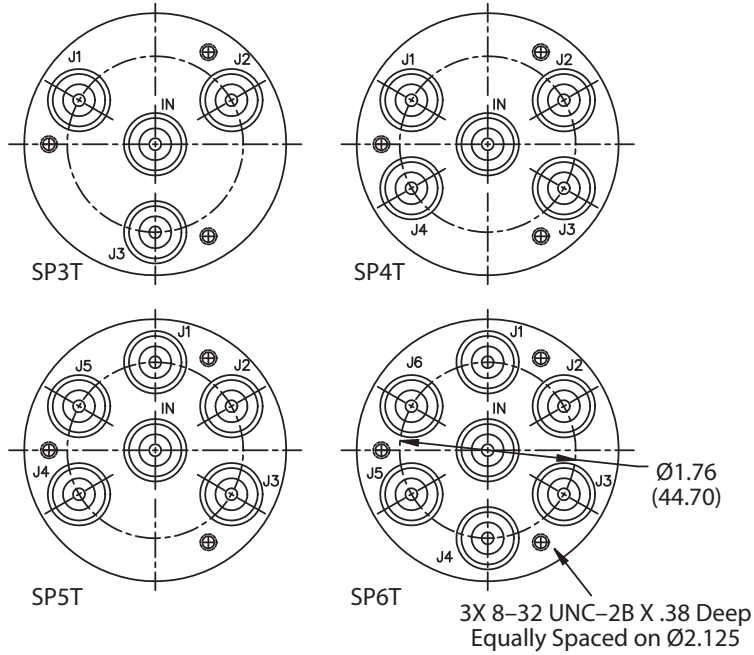

CCS-18/CS-18

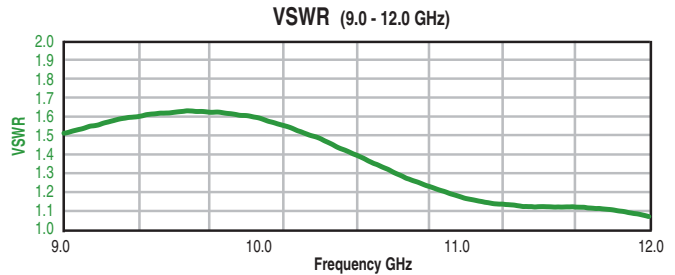
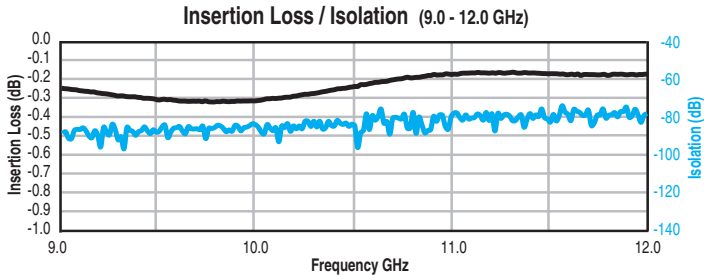
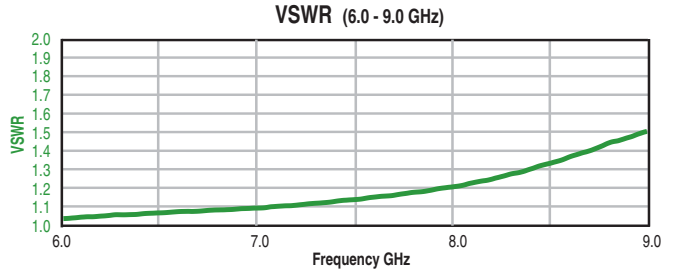
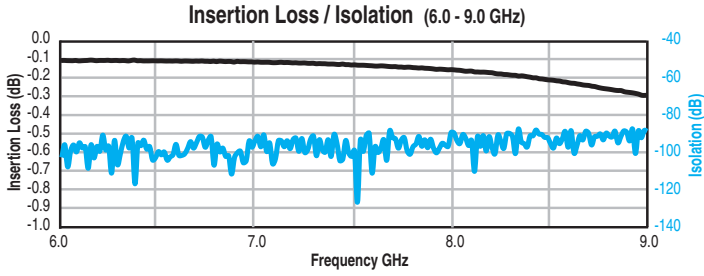
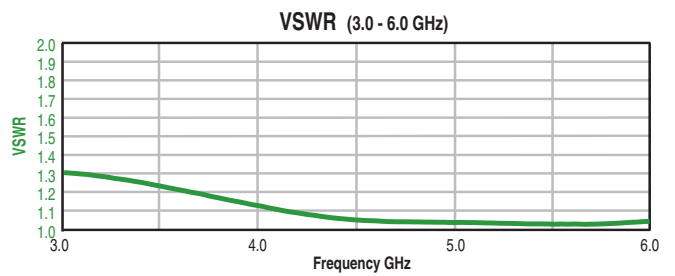
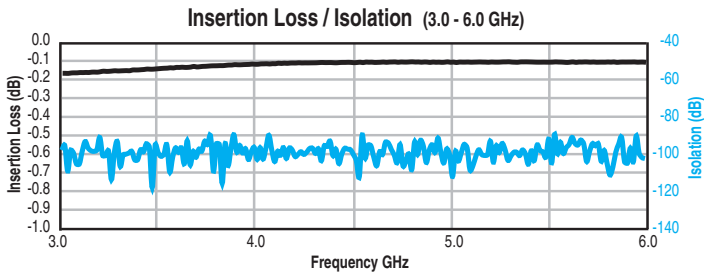
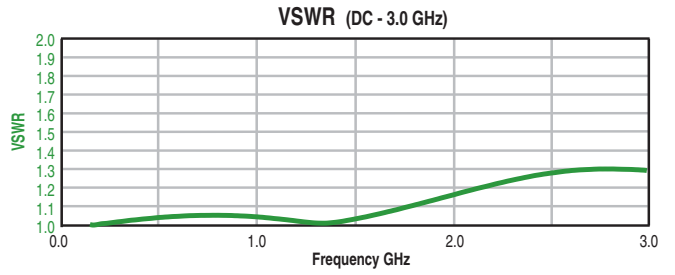
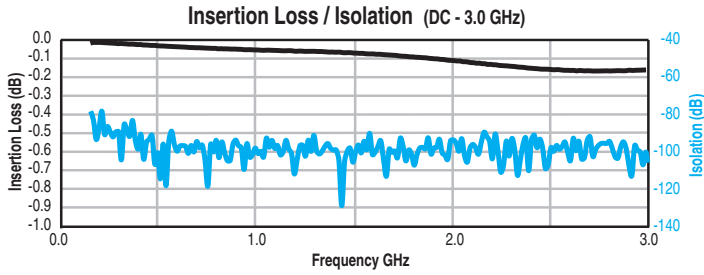

MULTI-THROW SWITCHES

CCS-19/CS-19

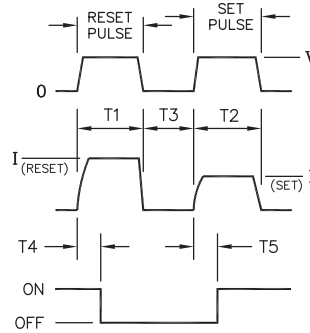
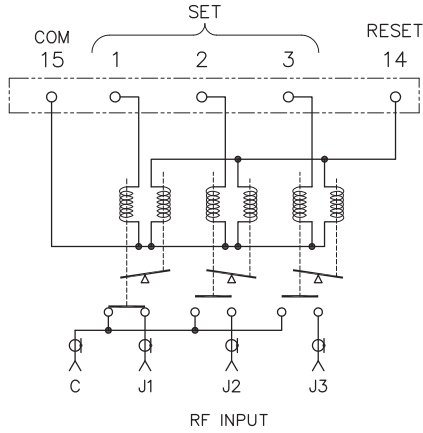

ACTUATION CHARACTERISTICS:

- REQUIRES TWO (2) SEQUENTIAL PULSES (RESET & SET)
- T1 & T2 = 30 mSEC MIN
- T3 = 10 mSEC MIN
- T4 & T5 = 20 mSEC MAX

MULTI-THROW SWITCHES

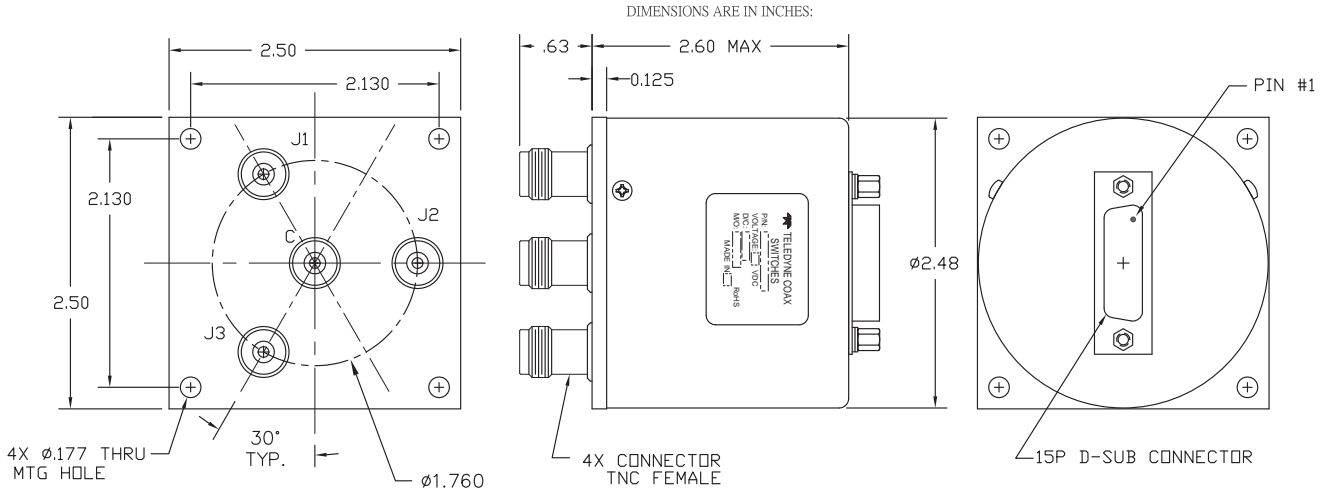

CCS-19/CS-19

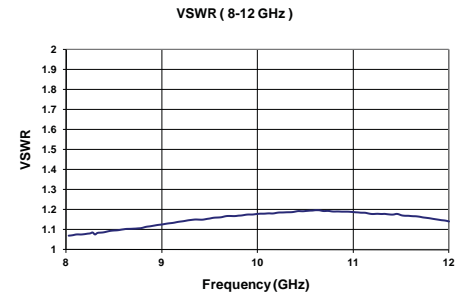
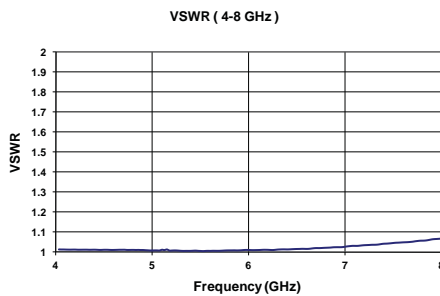
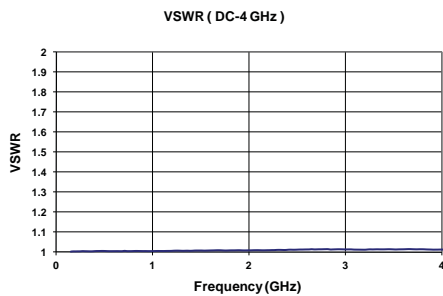
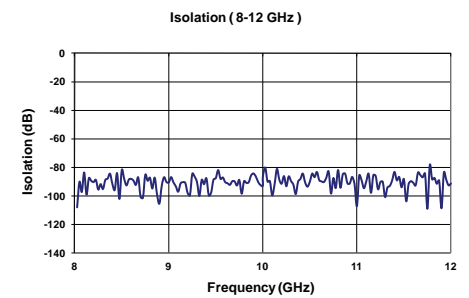
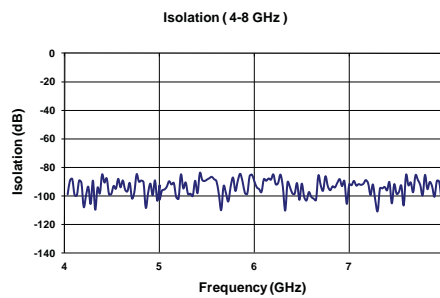
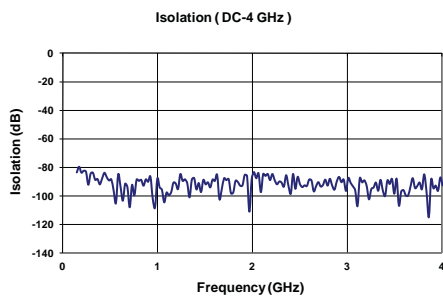
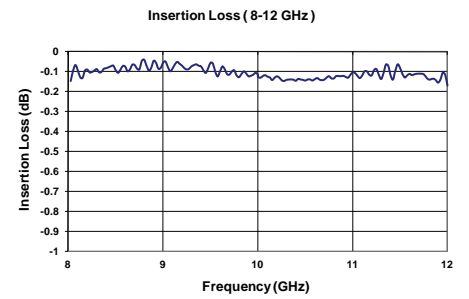
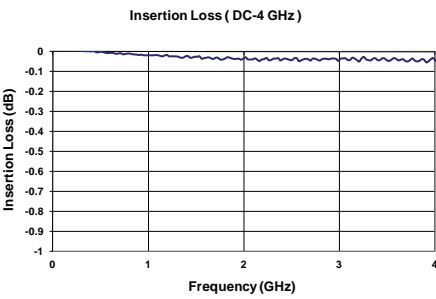

MULTI-THROW SWITCHES

CCP-33S

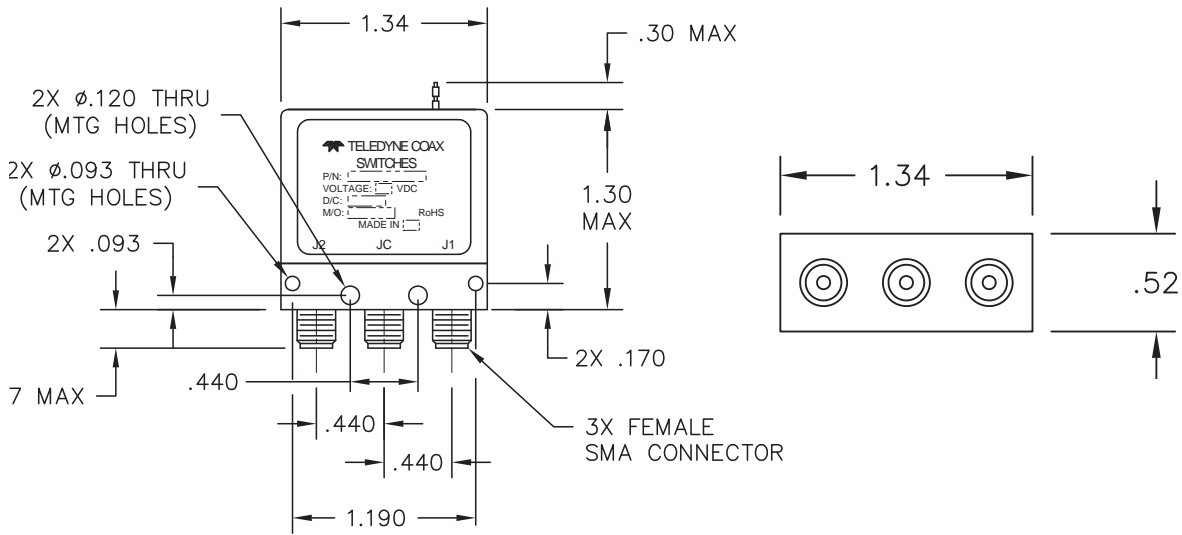

DIMENSIONS ARE IN INCHES:

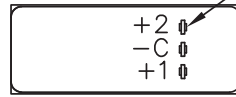
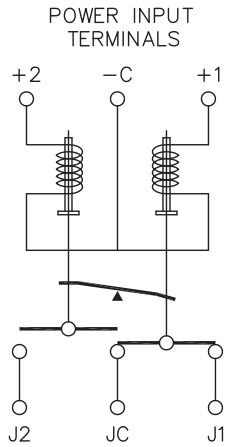

3X SOLDER D.C. WIRES TO TERMINALS MAXIMUM TEMP 250°C FOR NO MORE THAN 5 SEC

SCHEMATIC

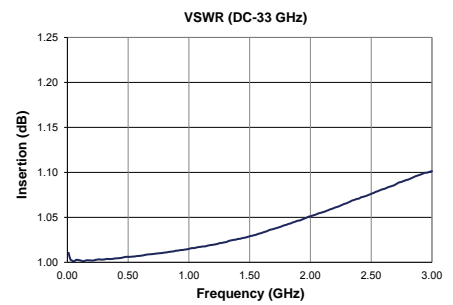
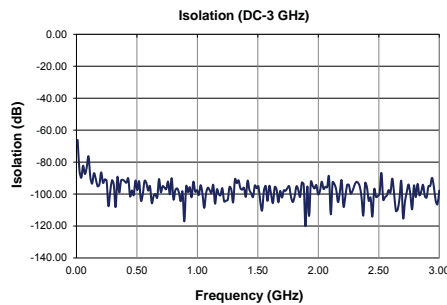
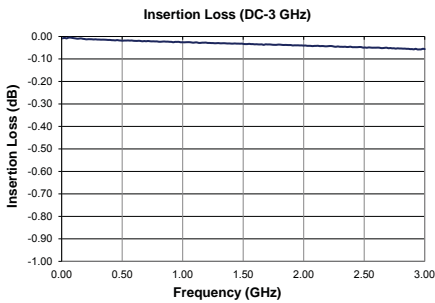

CCP-33N

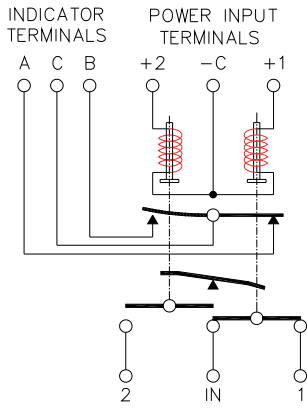

Indicators

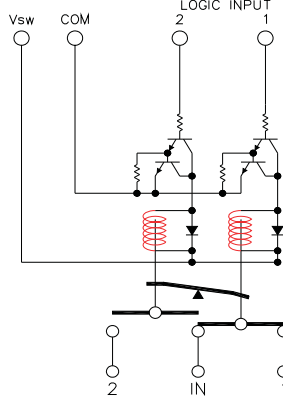

TTL

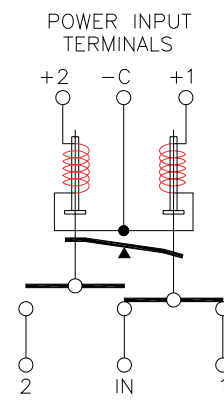

Analog

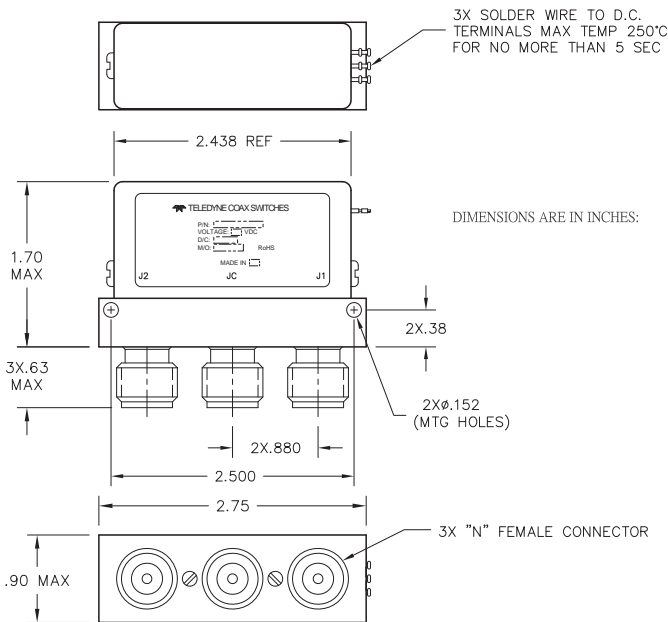

DIMENSIONS ARE IN INCHES:

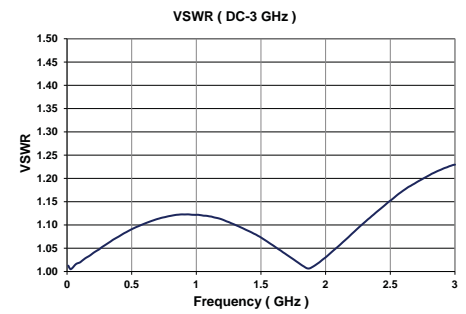
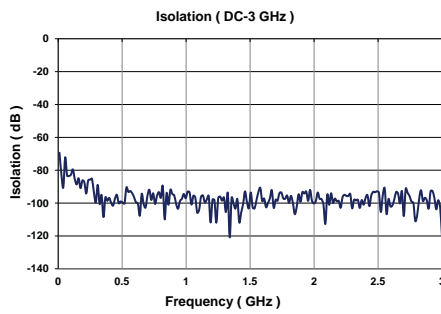
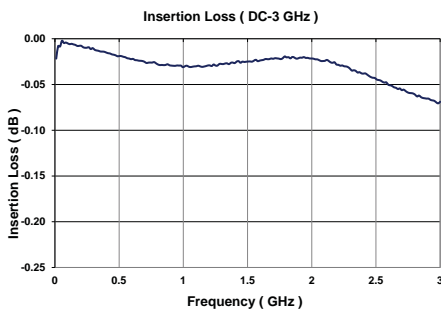
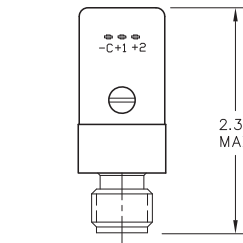

LOW PIM SWITCHES

CCP-33D

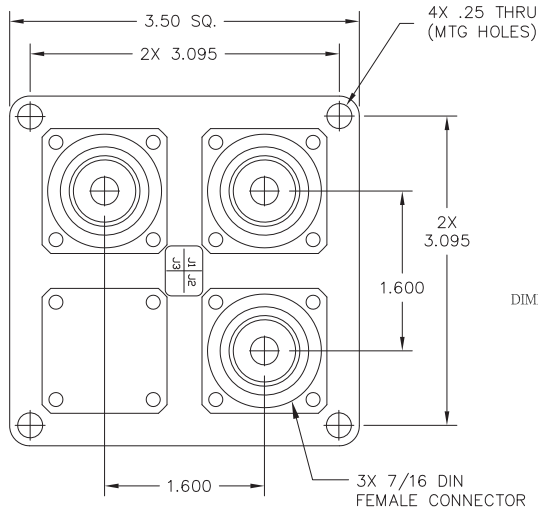

DIMENSIONS ARE IN INCHES:

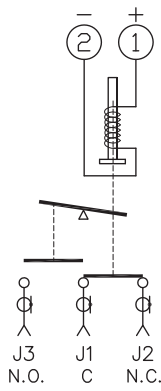
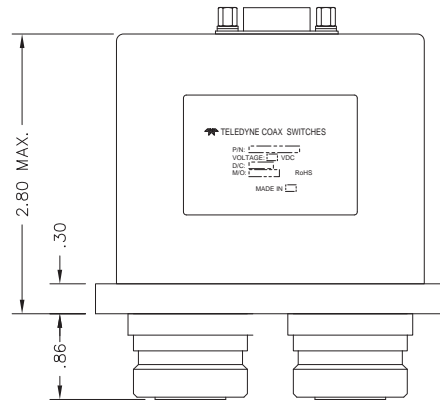

SCHMATIC

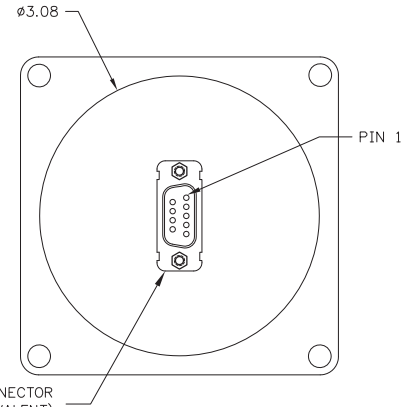

9-PIN SUB-D MINI CONNECTOR
AMP P/N 205556-2 (OR EQUIVALENT)
W/ 2X JACKPOST ITT CANNON
D110551 (OR EQUIVALENT)

LOW PIM SWITCHES

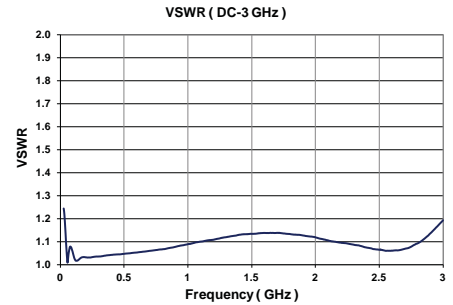
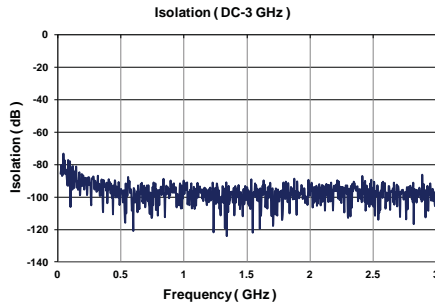
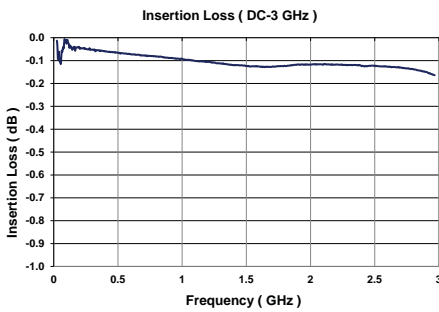

CCP-37S

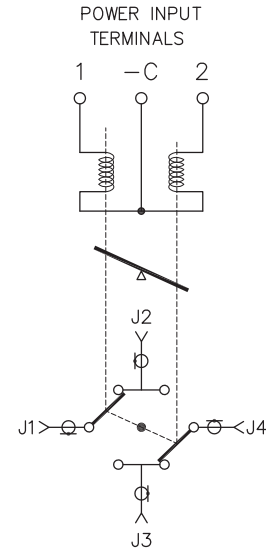
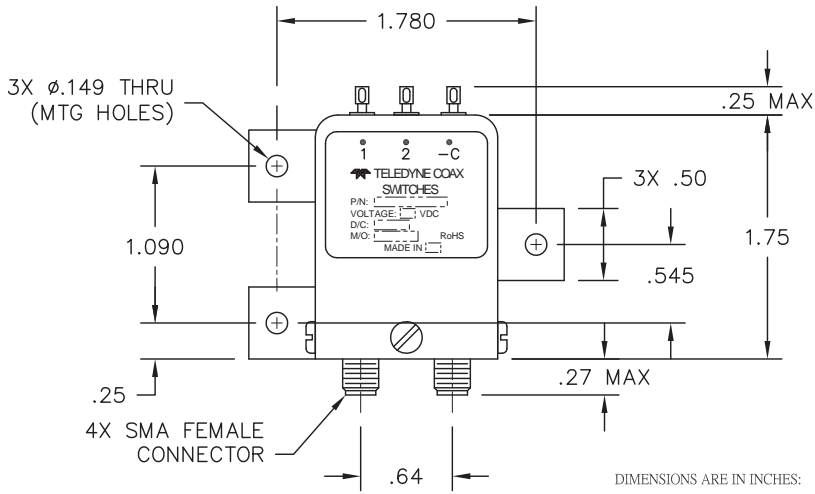

SCHEMATIC

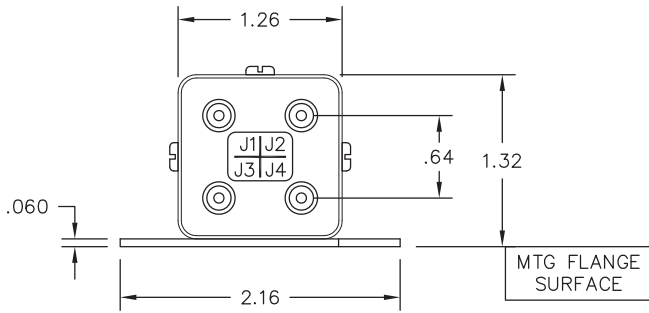

3X SOLDER WIRE TO D.C. TERMINALS MAX TEMP 250°C FOR NO MORE THAN 5 SEC

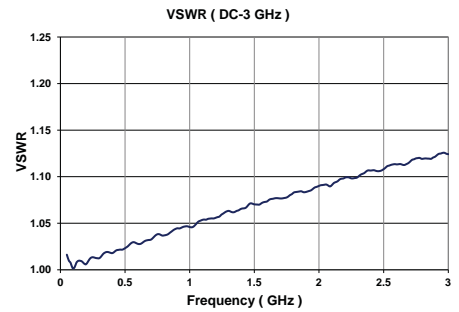
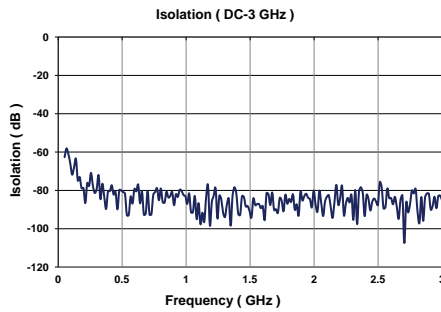
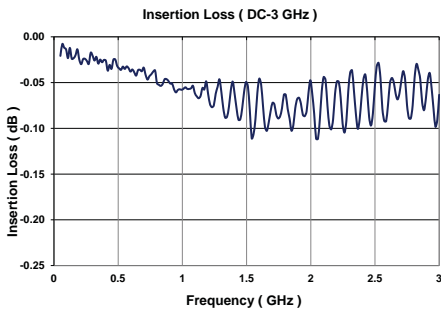
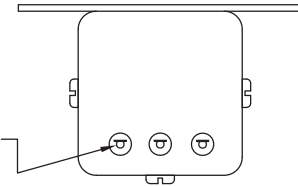

CCP-47N

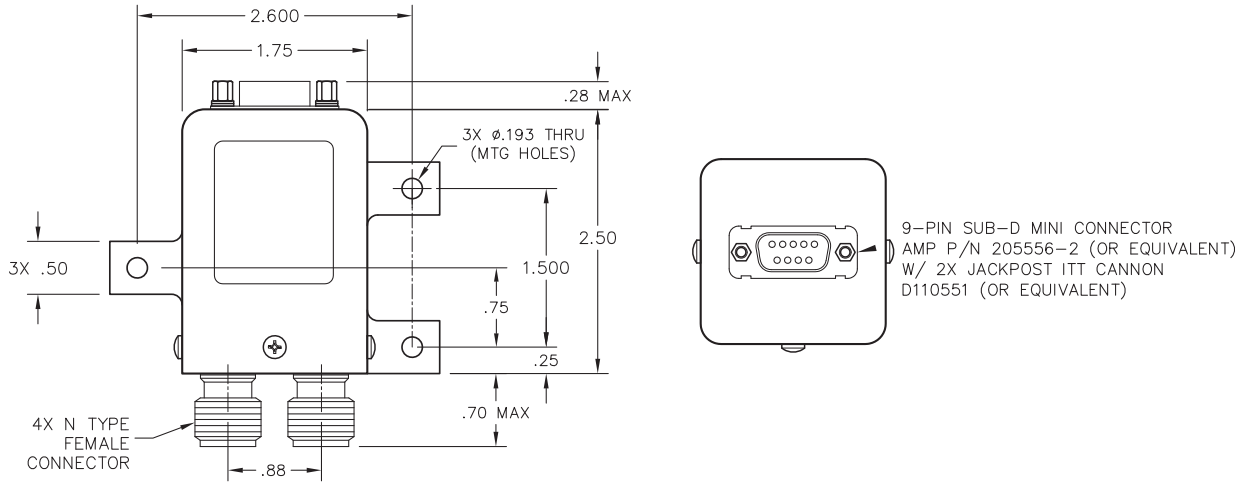

DIMENSIONS ARE IN INCHES:

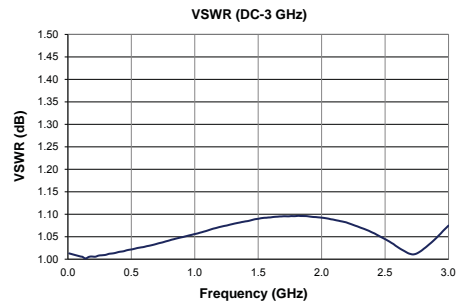
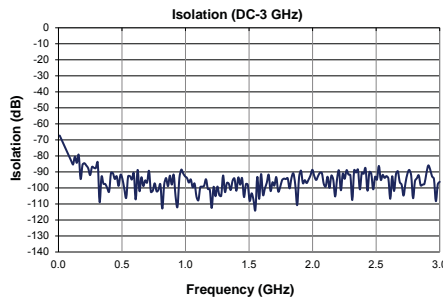
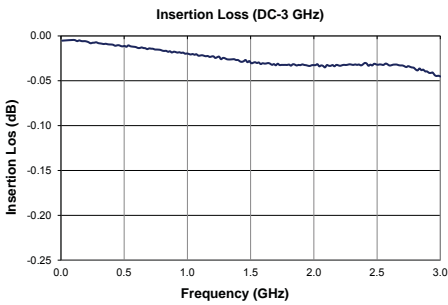
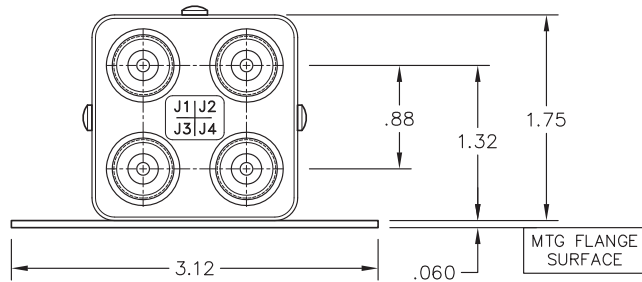
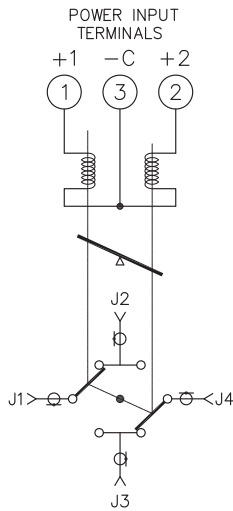

CCP-47D

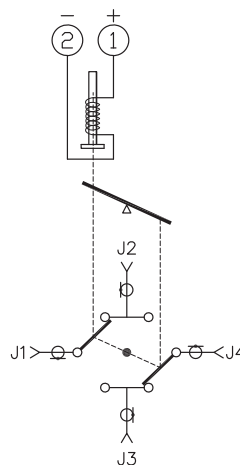
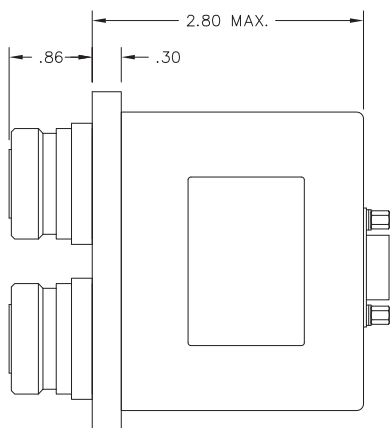

SCHEMATIC

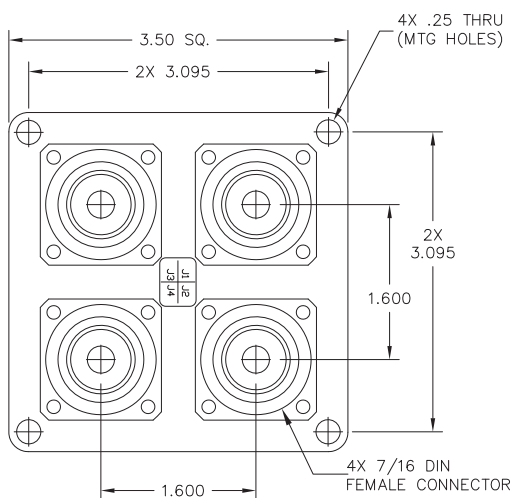

DIMENSIONS ARE IN INCHES:

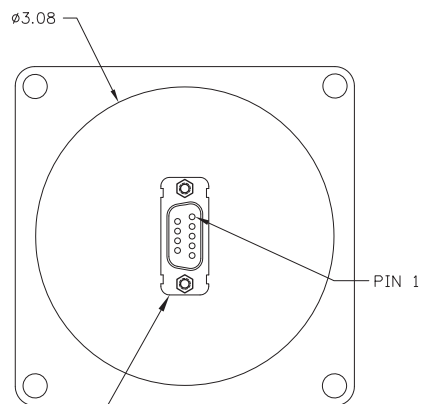

3-PIN SUB-D MINI CONNECTOR 'N' 205556-2 (OR EQUIVALENT) W/ 2X JACKPOST ITT CANNON D110551 (OR EQUIVALENT)

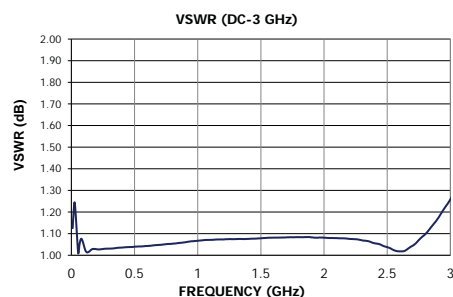
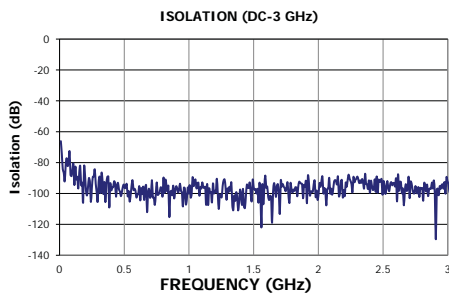
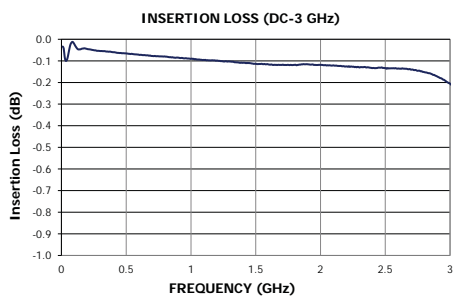

LOW PIM SWITCHES

CCP-18D

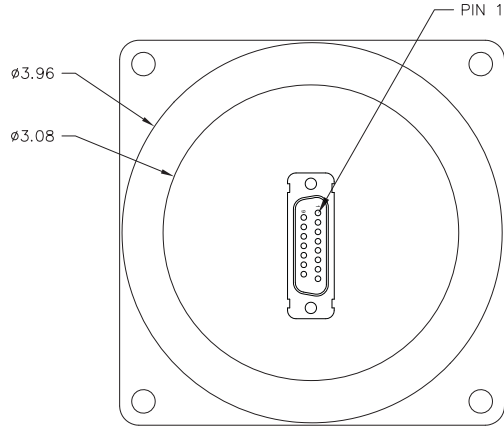
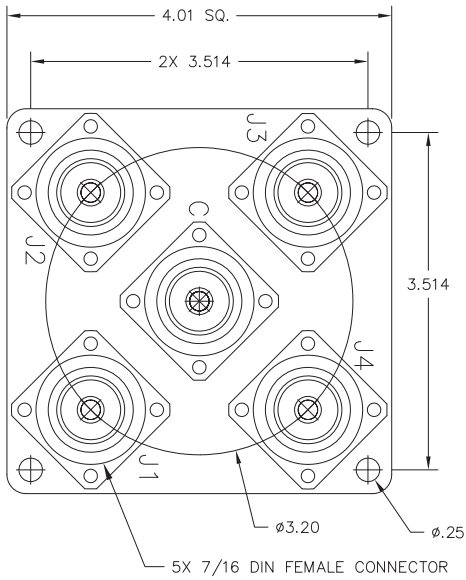

DIMENSIONS ARE IN INCHES:

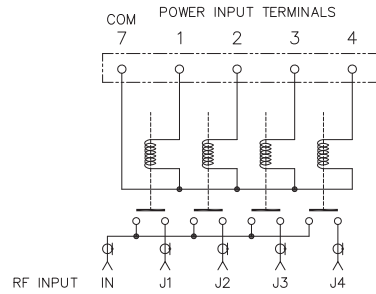
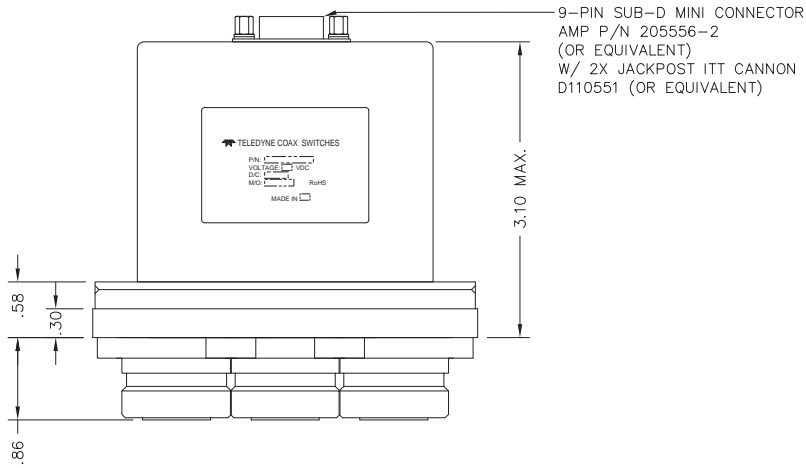

SCHEMATIC
SHOWN IN
NORMALLY OPEN POSITION

Insertion Loss (DC-3 GHz)

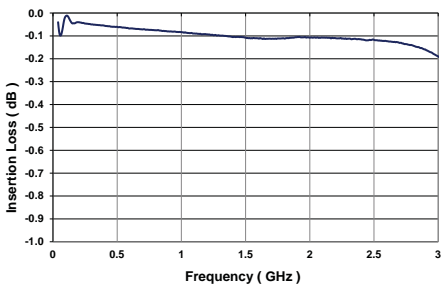

Isolation (DC-3 GHz)

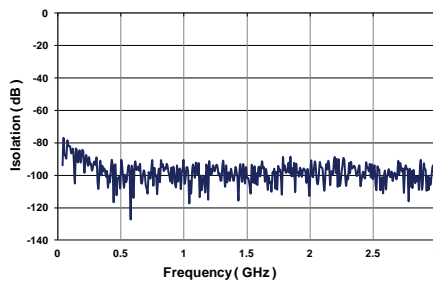

VSWR (DC-3 GHz)

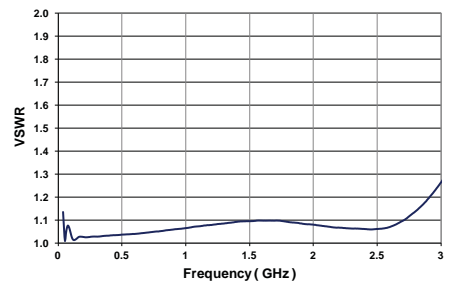

CCP-38S

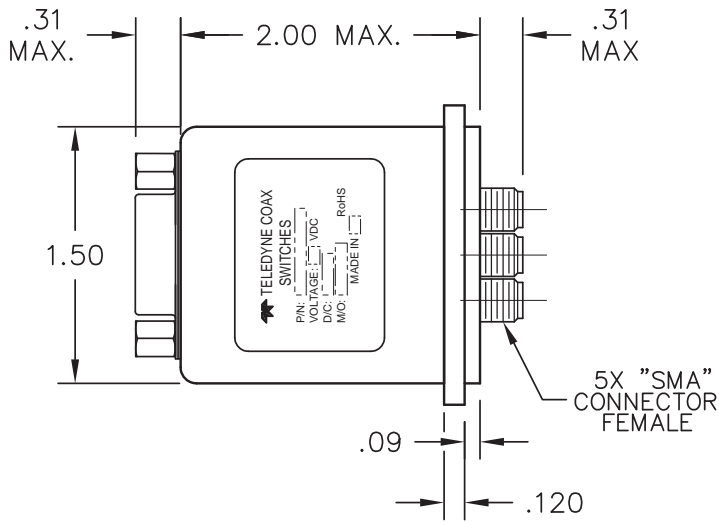

DIMENSIONS ARE IN INCHES:

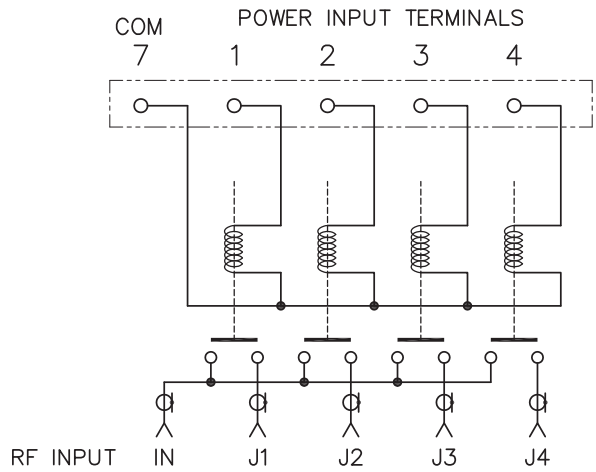
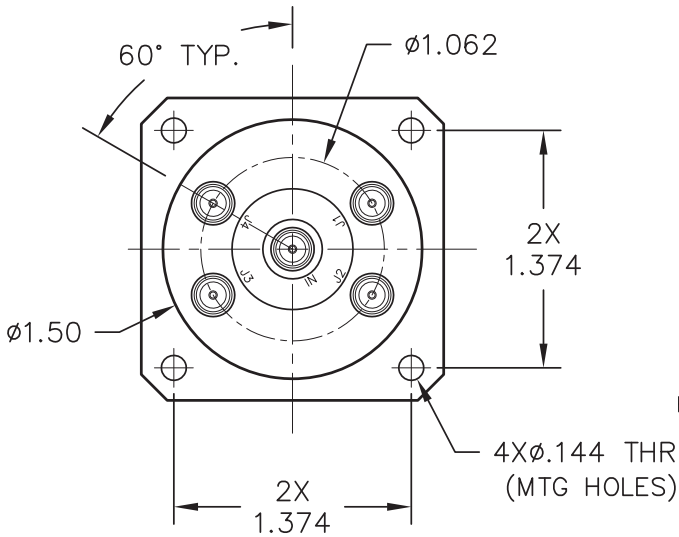
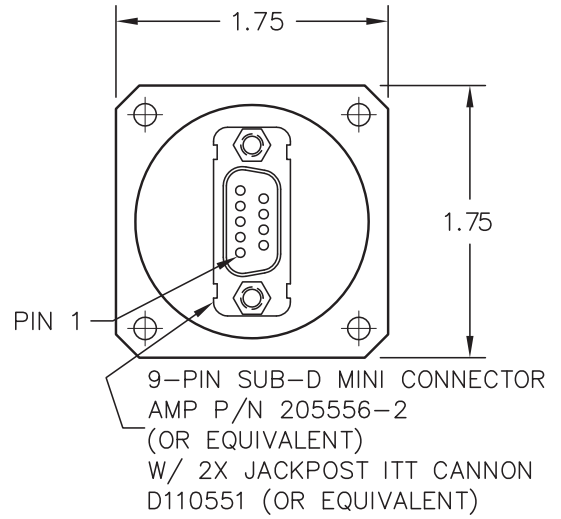

SCHEMATIC

SHOWN IN
NORMALLY OPEN POSITION

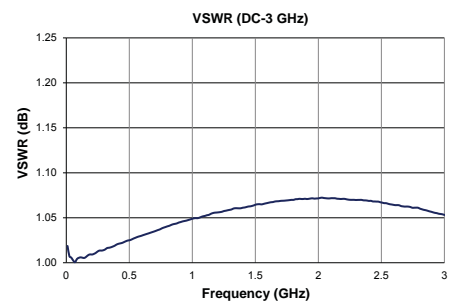
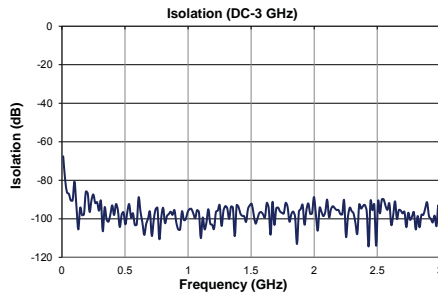
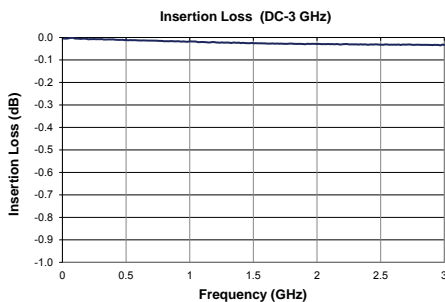

CCP-18N

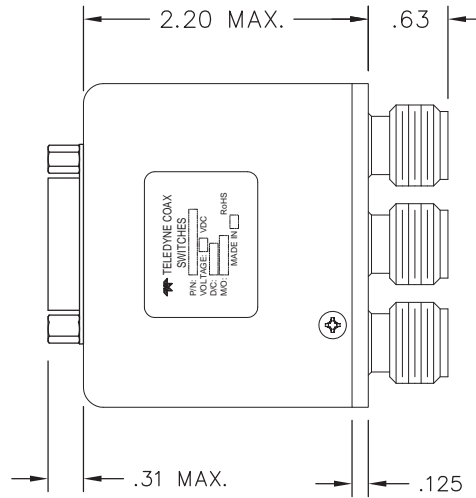
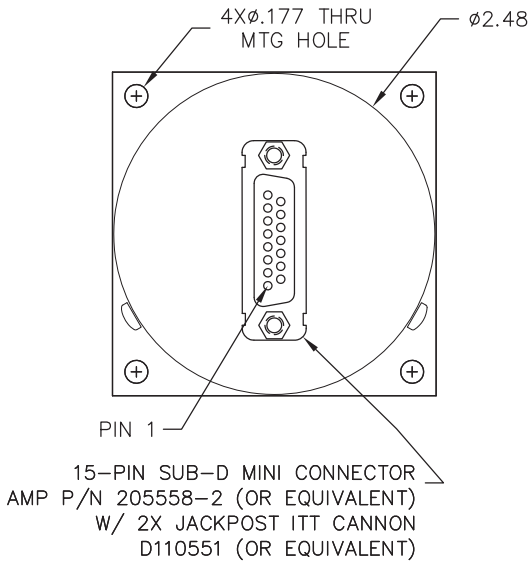

DIMENSIONS ARE IN INCHES:

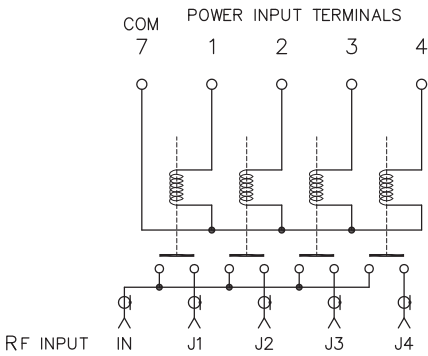

SCHMATIC

SHOWN IN
NORMALLY OPEN POSITION

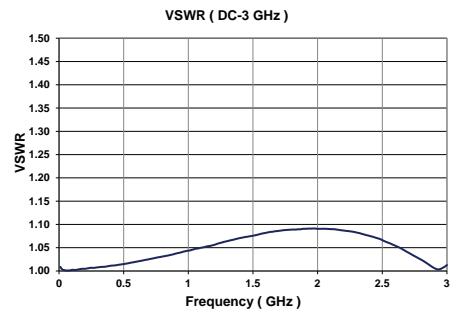
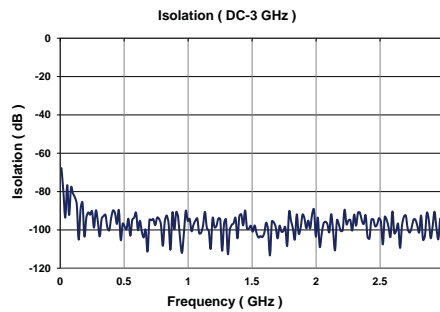
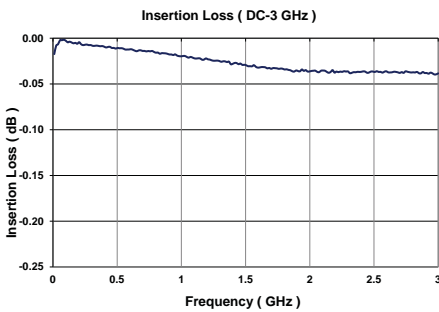
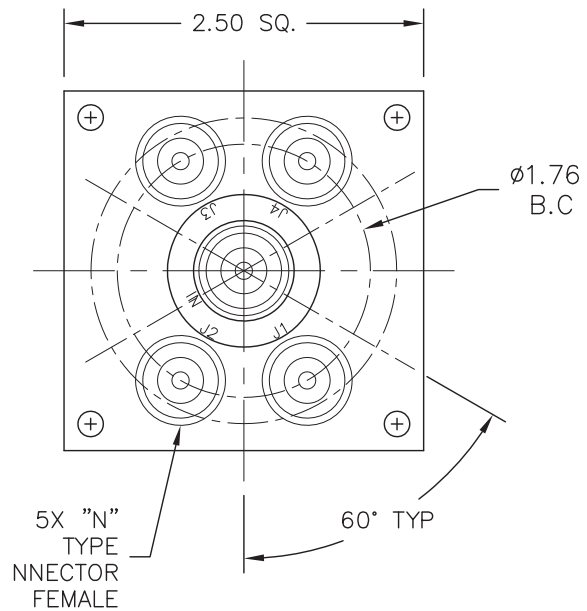

CAS-37

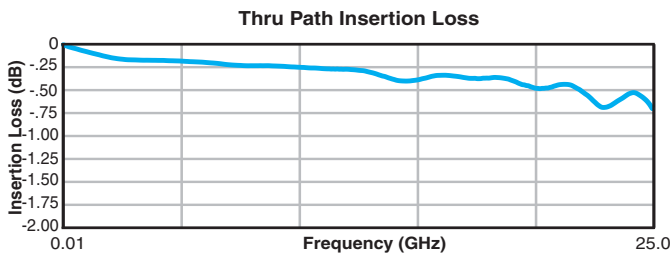
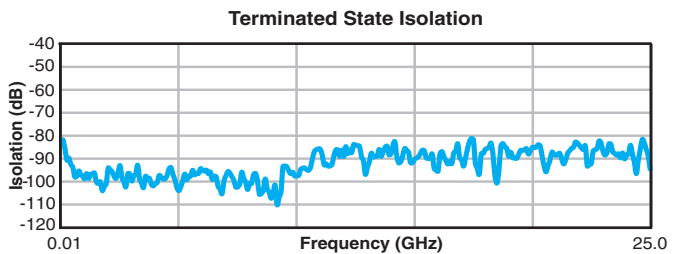
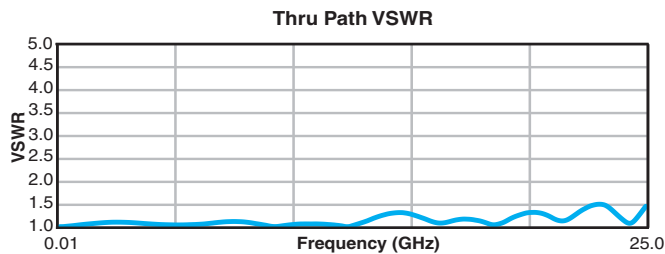
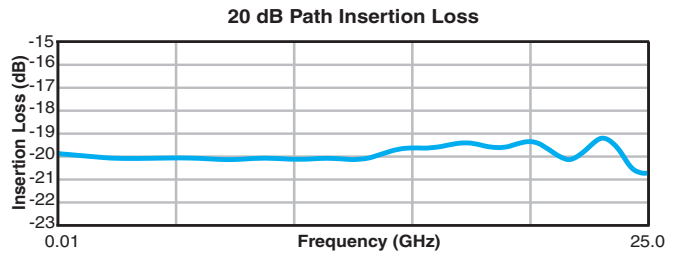
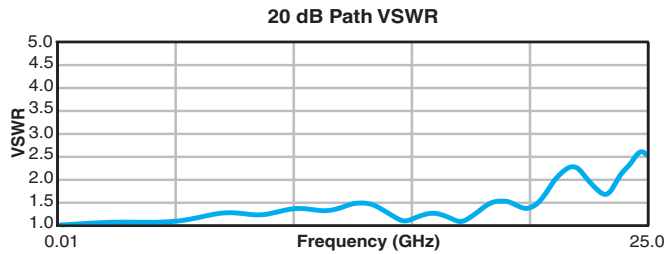
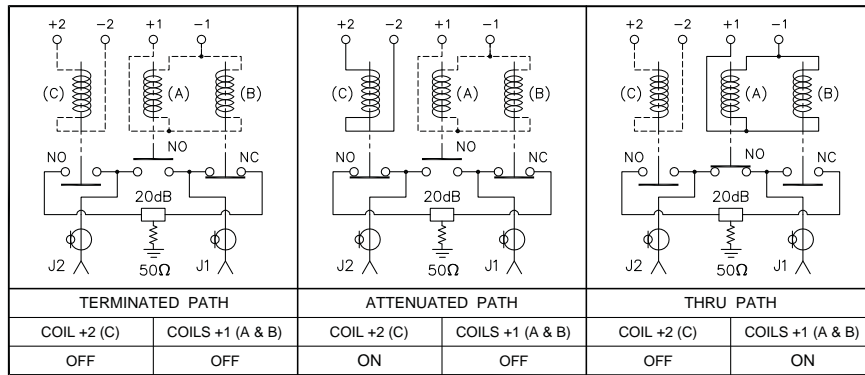
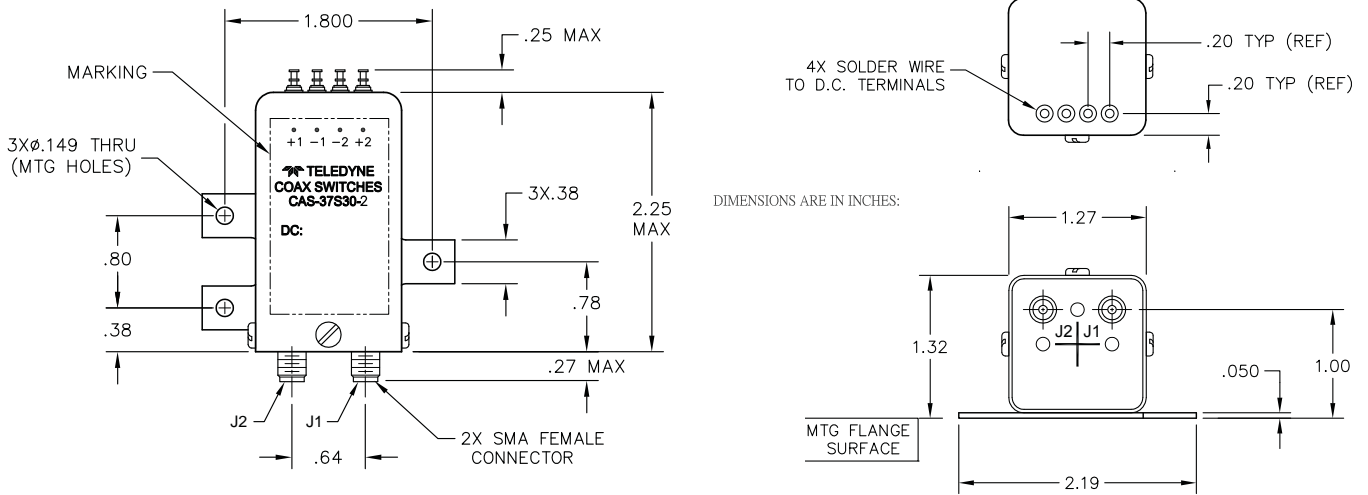

SPECIALTY SWITCHES

Coaxial Switches

Power Handling vs. Frequency

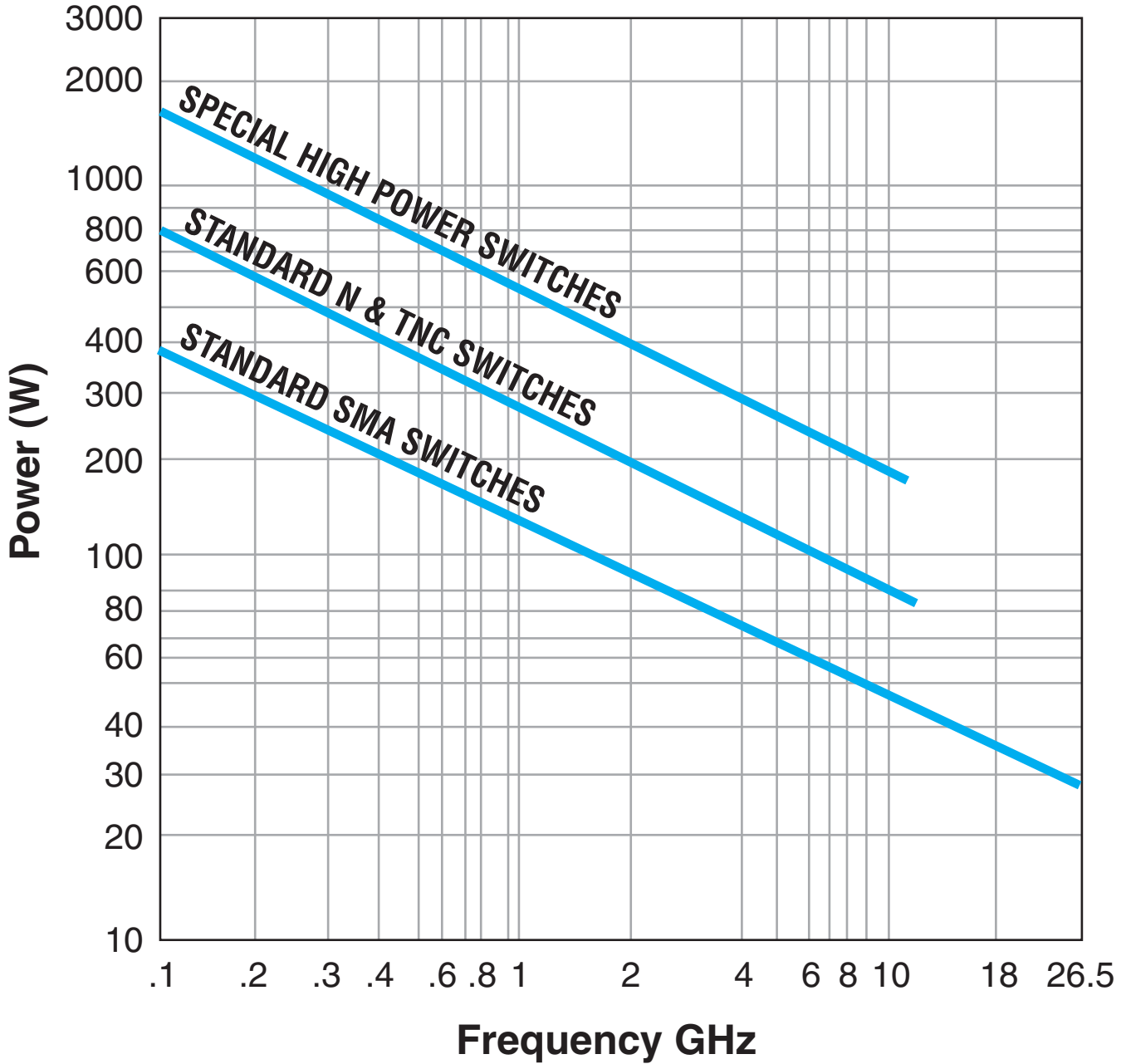

Estimates based on the following reference conditions:

- Ambient temperature of 40°C or less
- Sea level operation
- Load VSWR of 1.20:1 maximum
- No high-power (hot) switching

Please contact Teledyne Coax Switches for derating factors when applications do not meet the foregoing reference conditions.

Teledyne Coax Switches Offers Unrivaled Insertion Loss Repeatability

RF relays are rated for ± 0.1 dB repeatability for 1M cycles. Teledyne coaxial switches offer better than ± 0.1 dB over certain frequencies.



CCR-33 Insertion Loss Repeatability, 50K cycles

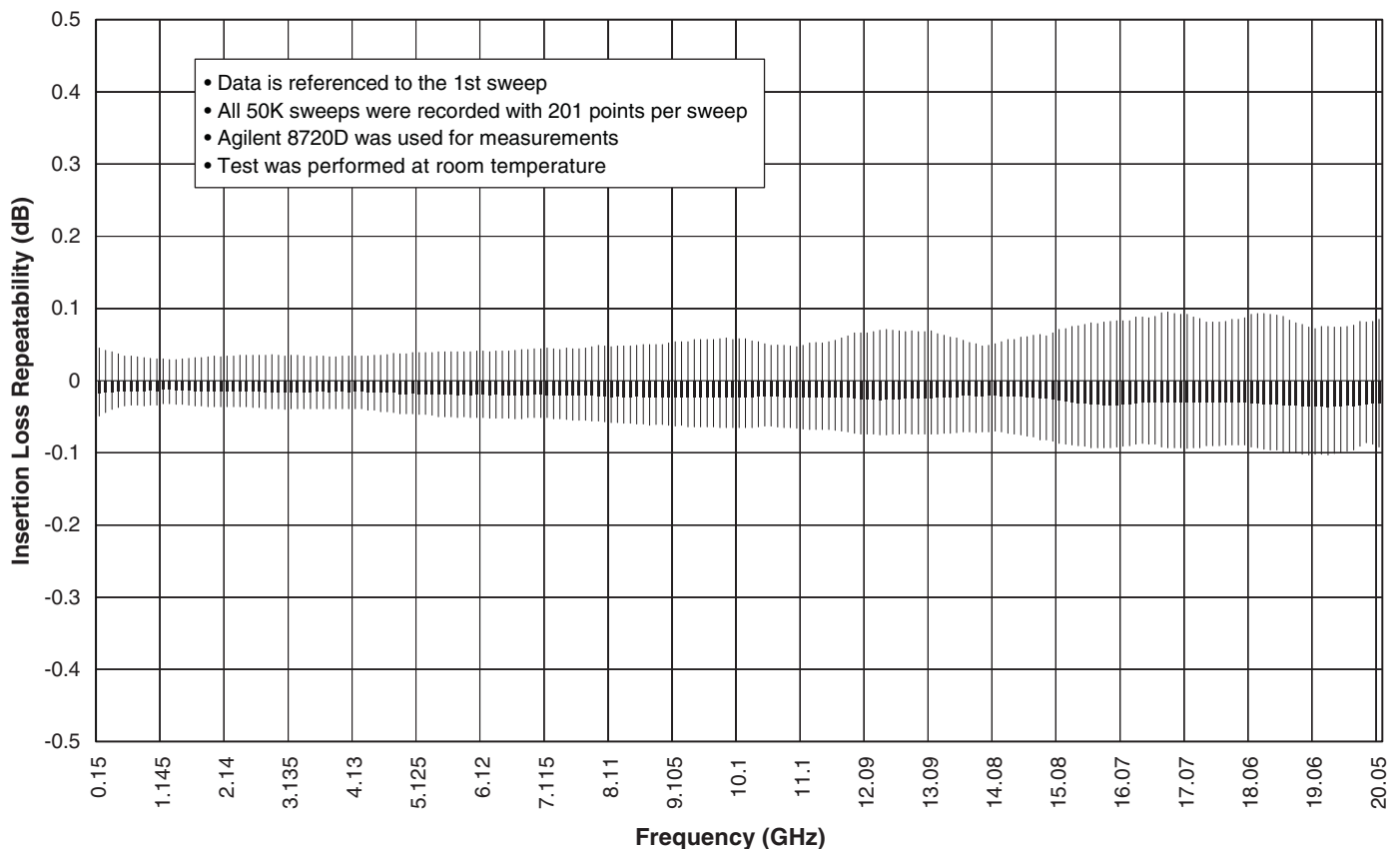

Microwave Switch

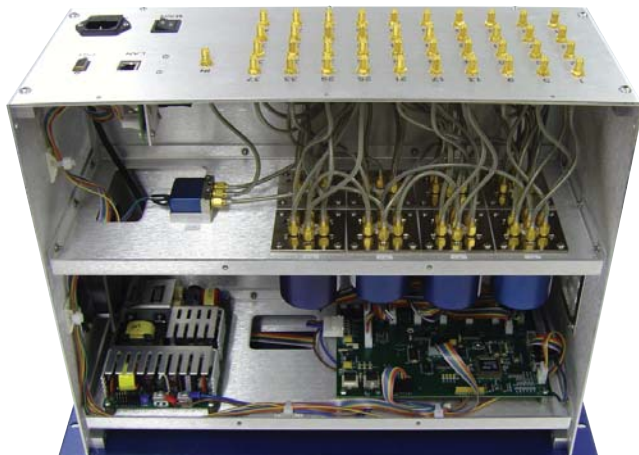
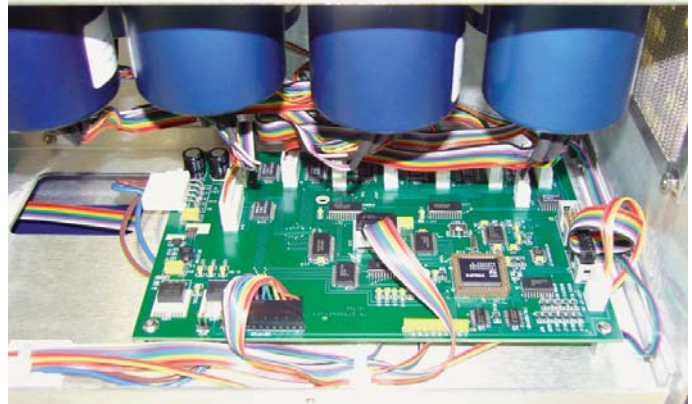

FEATURES

- Multiple standard and customized switching configurations
- Universal Power Supply
- Visual Display – LCD
- Standard and custom racks available
- Manual/direct and/or remote control
- Multiple interface configurations:
RF ports – SMA, N, SMB, TNC, etc.
Control – RS-232, Ethernet, PIO, Keypad, etc.
- 50 and 75 ohm impedances

ADDITIONAL FEATURES

- Monitor cycle count
- System health/system status
- LEDs: Visual status
- In-circuit programming (firmware upgradeable)

Matrix Assemblies



TYPICAL RF SWITCH PERFORMANCE

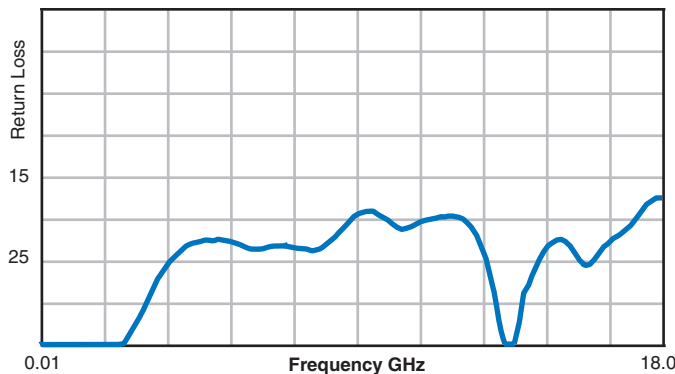
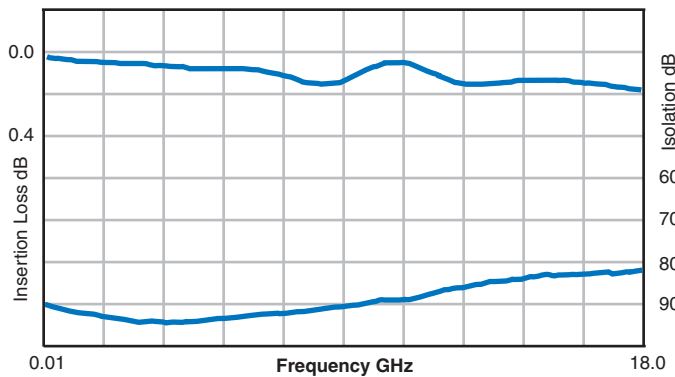

Teledyne, the world's innovative leader in manufacturing electromechanical and solid-state switching products for more than 50 years, offers a

modular approach to matrix assembly switching.

Incorporating highly repeatable and long-cycle-life relays and switches, Teledyne's matrices cover the spectrum from DC to 40GHz.



Teledyne's modular approach building matrices allows assembly of a vast array of customized matrix assemblies with the same standard subassemblies.



The internal components of the assembly and main module utilize Teledyne's proven relays and switches.

Teledyne has developed a standard programmable microcontroller that can be used for any matrix configuration. The universal power supply allows the matrix assembly to be used worldwide. Teledyne is highly vertically integrated, which reduces development time, qualification time, cost and leadtime, while ensuring high quality and cost-effective production.



To learn more, call us or visit us online today. And see what Teledyne Coaxial Switches can do for you.

Teledyne Coax Switches Insertion Loss Repeatability

SPDT Coaxial Switch 10 M Cycles Insertion Loss Repeatability (Contact 1)

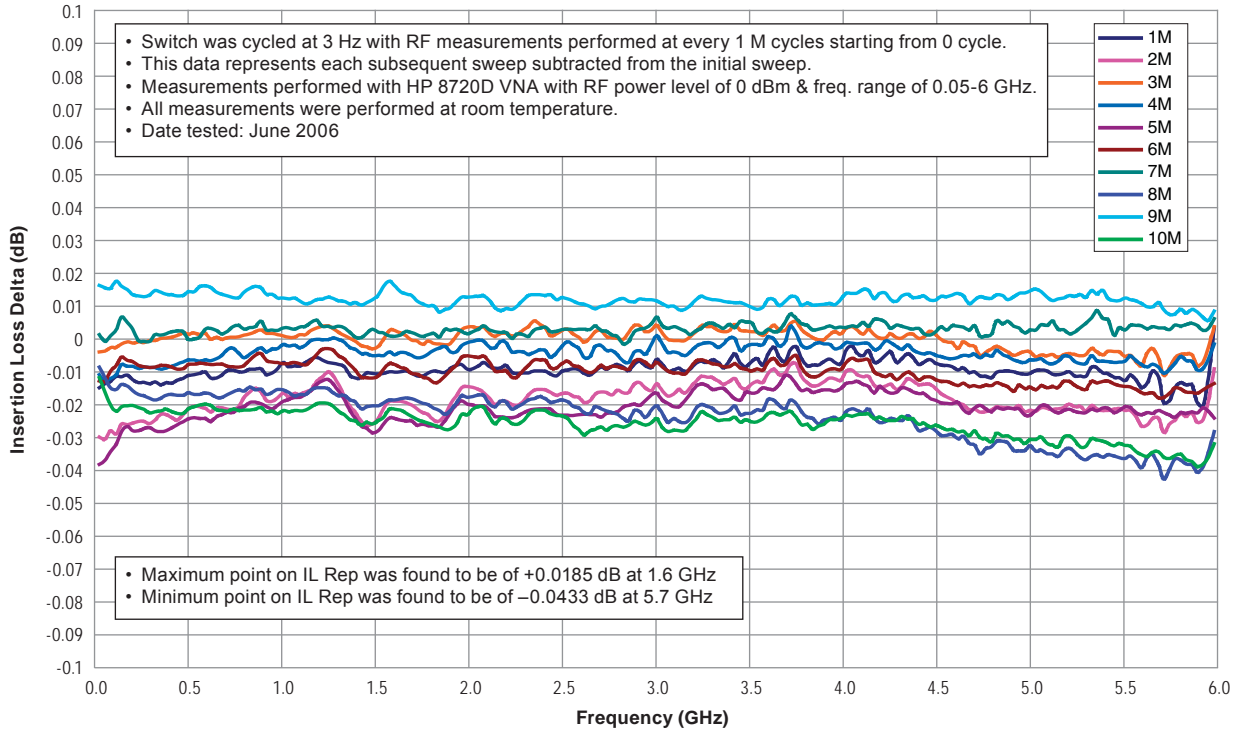

SPDT Coaxial Switch 10 M Cycles Insertion Loss Repeatability (Contact 2)

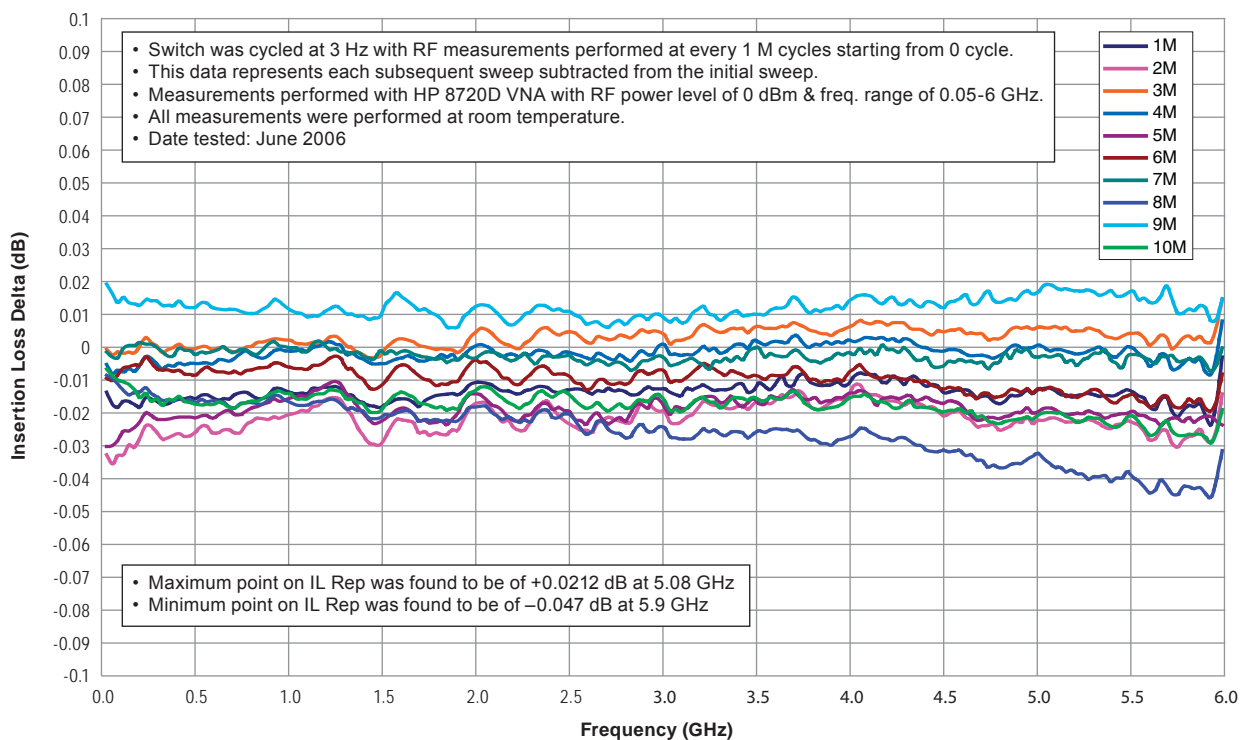

PERFORMANCE FEATURES

Teledyne Coax Offers Space-Qualified Switches!

Teledyne Coax Covers the RF Spectrum
for all of your space flight applications.

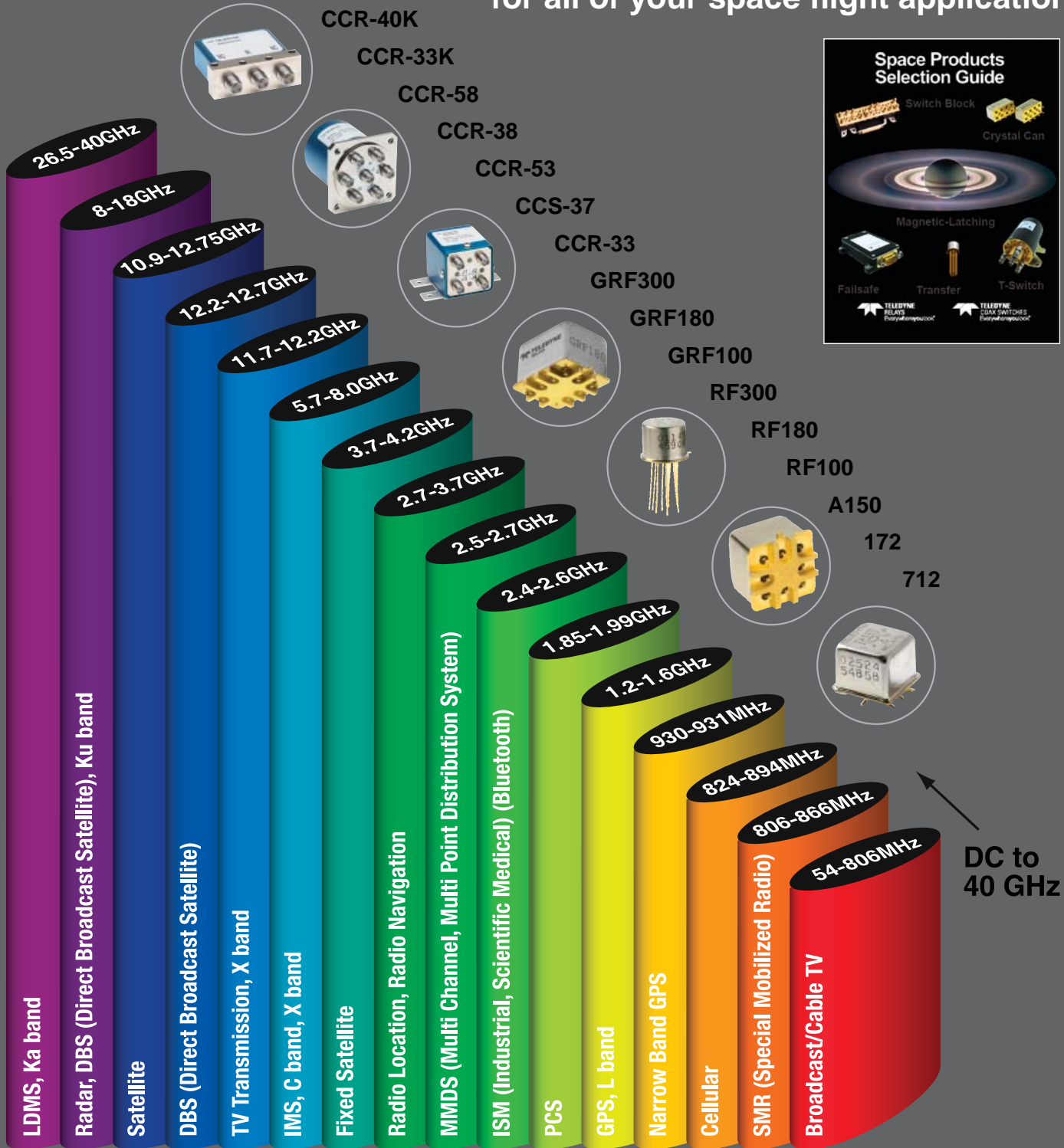

Actuator

An actuator is the electromechanical mechanism that transfers the RF contacts from one position to another upon DC command.

Arc Suppression Diode

A diode is connected in parallel with the coil. This diode limits the “reverse EMF spike” generated when the coil de-energizes to 0.7 volts. The diode cathode is connected to the positive side of the coil and the anode is connected to the negative side.

Date Code

All switches are marked with either a unique serial number or a date code. Date codes are in accordance with MIL-STD-1285 Paragraph 5.2.5 and consist of four digits. The first two digits define the year and the last two digits define the week of the year (YYWW). Thus, 0532 identifies switches that passed through final inspection during the 32nd week of 2005.

Failsafe

A failsafe switch reverts to the default or failsafe position when the actuating voltage is removed. This is realized by a return spring within the drive mechanism. This type of switch requires the continuous application of operating voltage to select and hold any position. (Multi-position switches are normally open with no voltage applied).

Latching

A latching switch remains in the selected position whether or not voltage is maintained. This can be accomplished with either a magnetic or mechanical latching mechanism.

Indicator

Indicators tell the system which position the switch is in. Other names for indicators are telemetry contacts or tellback circuit. Indicators are usually a set of internally mounted DC contacts linked to the actuator. They can be wired to digital input lines, status lights, or interlocks. Unless otherwise specified, the maximum indicator contact rating is 30 Vdc, 50 mA, or 1.5 Watts into a resistive load.

Internal Termination

Unselected ports are connected internally to a matched load. The load is a 50-Ohm resistive device. The max RF power rating is 2 watts CW. Without the internal termination option, the unselected ports are open circuits.

Isolation

Isolation is the measure of the power level at the output connector of an unconnected RF channel as referenced to the power at the input connector. It is specified in dB below the input power level.

Multi-Throw Switch

A multi-throw switch is a switch with one input and three or more output ports. The CCT-58 can switch a microwave signal to any of 2, 3, 4, 5 or 6 outputs from a single common input.

Multi-Throw Latching Switch

- DUAL PULSE SWITCHING COMMAND CHARACTERISTICS:
1. APPLIES FOR SINGLE-POLE MULTI-THROW LATCHING SWITCH ONLY.
 2. MUST APPLY RESET PULSE FIRST (BREAK-BEFORE-MAKE).
 3. RESET AND SET DEFINITIONS
RESET: OPEN ALL RF PATHS (POSITIONS).
SET: CLOSE THE SELECTED RF PATH (POSITION).
 4. COMMAND PULSE TIMING:

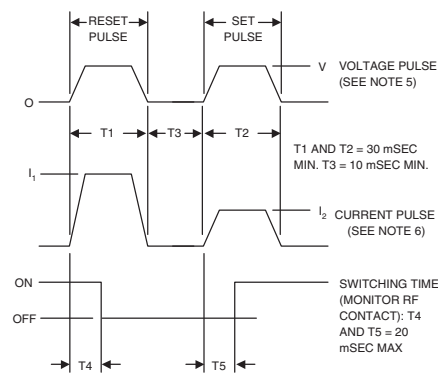

5. COMMAND SWITCHING VOLTAGE:
V = 26-32 VDC PULSE

6. SWITCHING CURRENT:

SWITCHING CURRENT AT 28 VDC AND 20°C		
NO. OF POS.	RESET (I ₁)	SET (I ₂)
3 POS.	270 mA	90 mA
4 POS.	360 mA	90 mA
5 POS.	450 mA	90 mA
6 POS.	540 mA	90 mA

Self-Cutoff

The self-cutoff option disables the actuator current on completion of actuation. Either a series contact (linked to the actuator) or an IC driver circuit provides the current cutoff. This option results in minimum power consumption by the RF switch. Cutthroat is another name used in the industry for this option. Pulse latching is a term sometimes used to describe a switch without this feature.

SPDT Switch

A single-pole double-throw switch has one input and two output ports.

Switching Time

Switching time is the total interval beginning with the arrival of the leading edge of the command pulse at the switch DC input and ending with the completion of the switch transfer, including contact bounce. It consists of three parts: (1) inductive delay in the coil, (2) transfer time of the physical movement of the contacts, and (3) the bounce time of the RF contacts.

Transfer Switch

A four-port switch consisting of two independent pairs of RF paths. These pairs are actuated simultaneously. This actuation is similar to that of a double-pole double-throw switch. See application notes for typical usage.

TTL Switch Driver Option

As a special option, switch drivers can be provided for both failsafe and latching switches, which are compatible with industry-standard low-power Schottky TTL circuits.

T-Option

This option is for TTL Driver. There is one control input for each position. See the logic table.

TD-Option

This option includes a decoder. The 3-bit parallel command is decoded to internally select the appropriate position. See the logic table.

The TD-Option increases the Vsw supply current demand by 50mA max at 28 Vdc and +20°C.

Failsafe uses 1 circuit. Latching uses 2 circuits (Vsw & C are common to both circuits).

Glossary

Performance Parameters vs Frequency

Generally speaking, the RF performance of coaxial switches is frequency dependent. With increasing frequency, VSWR and insertion loss increase while isolation decreases. All data sheets specify these three parameters as “worst case” at the highest operating frequency. If the switch is to be used over a narrow frequency band, better performance can be achieved.

Actuator Current vs Temperature

The resistance of the actuator coil varies as a function of temperature. There is an inverse relationship between the operating temperature of the switch and the actuator drive current. For switches operating at 28 VDC, the approximate actuator drive current at temperature, T, can be calculated using the equation:

$$I_T = \frac{I_A}{[1 + .00385 (T-20)]}$$

Where:

I_T = Actuator current at temperature, T

I_A = Room temperature actuator current – see data sheet

T = Temperature of interest in °C

Magnetic Sensitivity

An electro-mechanical switch can be sensitive to ferrous materials and external magnetic fields. Neighboring ferrous materials should be permitted no closer than 0.5 inches and adjacent external magnetic fields should be limited to a flux density of less than 5 Gauss.

Series Application of Multi-Throw Switches

This example shows a single-pole 9-throw unit made up of four 3-throw switches. The number of throws possible using this technique is essentially unlimited and is equal to the total number of throws available in the output stage. If a two-stage unit were set up using six position switches, the resultant would be a total of 36 outputs or a SP36T switch bank. See Figure 1.

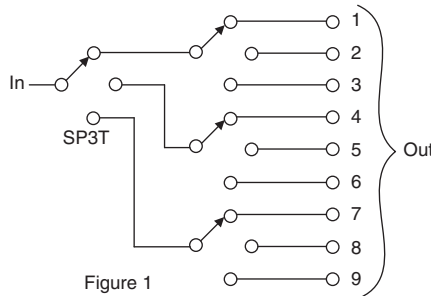

Figure 1

Transfer Switch

The transfer switch is essentially a modified double-pole-double-throw (DPDT) device. However, a true DPDT switch is a six port device that contains two totally independent transmission paths. In a transfer switch two transmission paths are provided but they are not totally independent as illustrated in Figure 2.

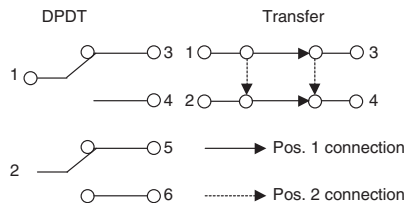

Figure 2

Examples of applications of the transfer switch are as follows:

Two Transmitters to Either of Two Antennas

Two microwave transmitters can be connected to either of two alternate antennas as shown in Figure 3.

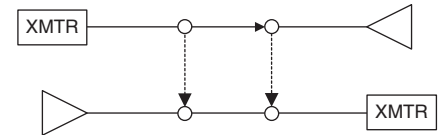

Figure 3

Circuit Insertion

A complete microwave circuit or circuit element can be inserted into a transmission line by using a transfer switch as shown in Figure 4.

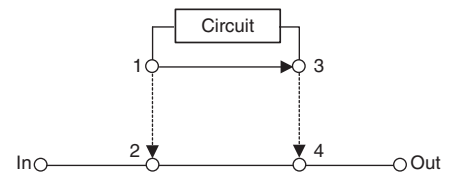

Figure 4

In the event that the 1-3 shorting of the microwave circuit is undesirable, this leg can be left out.

Special Feature

Switching High-Power or Highly Sensitive Signals

Ensure the most linear response with the best galvanically matched contact system in the industry. Extremely low passive intermodulation is standard on all of our switches.

Carrier Frequency 1	Carrier Frequency 2	PIM 3rd Order Frequency	PIM 5th Order Frequency
870 MHz	893 MHz	847 MHz	824 MHz

	3rd Order Intermodulation	5th Order Intermodulation
SPDT	-91 dBm	-110 dBm
	-134 dBc	-153 dBc
Transfer	-103 dBm	-123 dBm
	-146 dBc	-165 dBc
Multiple Positions	-96 dBm	-115 dBm
	-139 dBc	-158 dBc

HEADQUARTERS

12525 Daphne Ave.
Hawthorne, CA 90250
Phone: (323) 777-0077 or (800) 351-7368
Fax: (323) 241-1287
E-mail: coax@teledyne.com

www.teledynecoax.com
(800) 351-7368

EUROPE

9-13 Napier Road
Wardpark North
Cumbernauld G68 OEF
Scotland UK
Phone: +44 (0) 1236 453 124
Fax: +44 (0) 1236 780 651
E-mail: sales_europe@teledyne.com

www.teledyne-europe.com
+44 (0) 1236 453 124



TELEDYNE
COAX SWITCHES
Everywhereyoulook™