

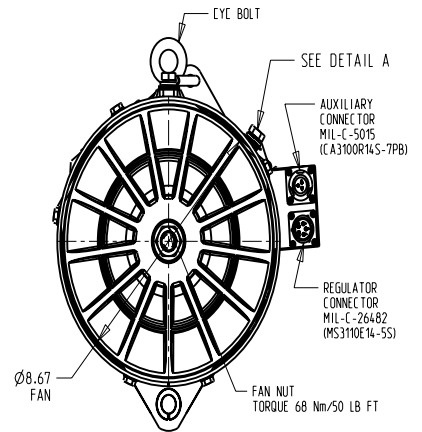

C.E. Niehoff & Co.
BRUSHLESS ALTERNATORS

N1611
28V 570A

DESIGNING FOR TOMORROW'S DEMANDS

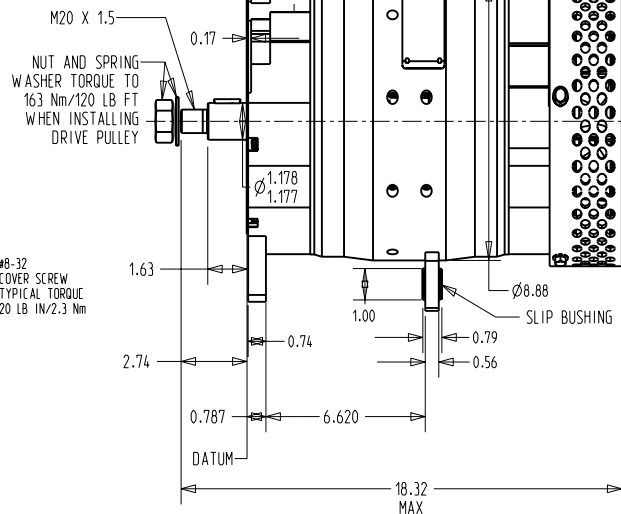
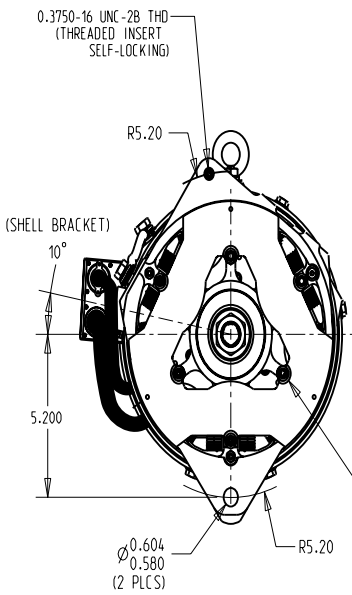
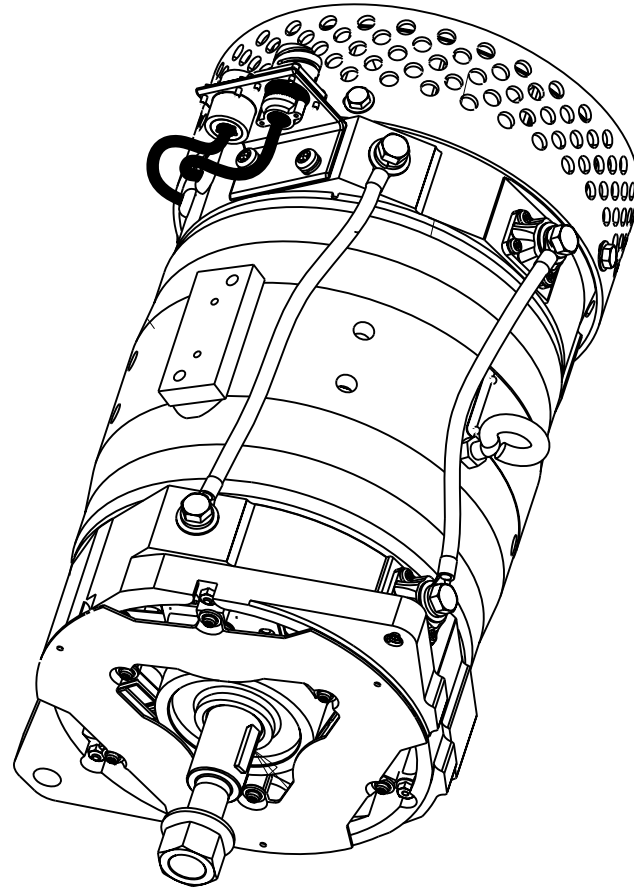



C.E. Niehoff & Co.
BRUSHLESS ALTERNATORS

N1611
28V 570A

DESIGNING FOR TOMORROW'S DEMANDS

ALTERNATOR CHARACTERISTICS FOR 28 VOLTS/ 570 AMPS:

APPLICABLE MODELS: N1611

OUTPUT CURVE: OUTPUT AMPERES VERSUS ALTERNATOR SHAFT SPEED IN RPM AT 28.0 VOLTS.

TORQUE CURVE: DRIVE TORQUE IN Nm VERSUS ALTERNATOR SHAFT SPEED IN RPM REQUIRED TO PRODUCE OUTPUT CURVE.

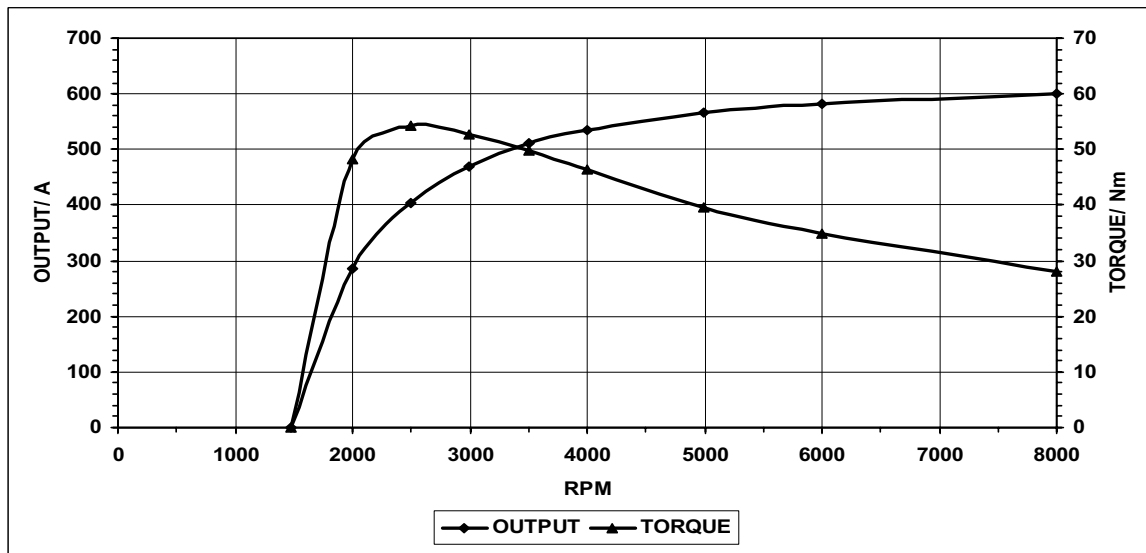

ALL MEASUREMENTS DEPICTED ON PERFORMANCE CURVES ARE TAKEN AT 22 °C/72°F AMBIENT TEMPERATURE (UNLESS OTHERWISE SPECIFIED) AND A STABILIZED MACHINE TEMPERATURE AT MAXIMUM OUTPUT WITH VOLTAGE CONSTANT AS SPECIFIED.

ABBREVIATIONS:

RPM REVOLUTIONS PER MINUTE

Nm NEWTON-METER

Conversion: 1 Nm = 8.85 Pound Inch (LBIN)



C.E. Niehoff & Co.
BRUSHLESS ALTERNATORS

N1611
28V 570A

DESIGNING FOR TOMORROW'S DEMANDS

ALTERNATOR CHARACTERISTICS FOR 28 VOLTS/ 570 AMPS:

APPLICABLE MODELS: N1611

DRIVE CURVE: DRIVE HORSEPOWER OR kW VERSUS ALTERNATOR SHAFT SPEED IN RPM REQUIRED TO PRODUCE OUTPUT CURVE.

EFFICIENCY CURVE: EFFICIENCY IN PERCENTAGE OF ALTERNATOR OUTPUT POWER DIVIDED BY INPUT POWER VERSUS ALTERNATOR SHAFT SPEED IN RPM REQUIRED TO PRODUCE OUTPUT CURVE

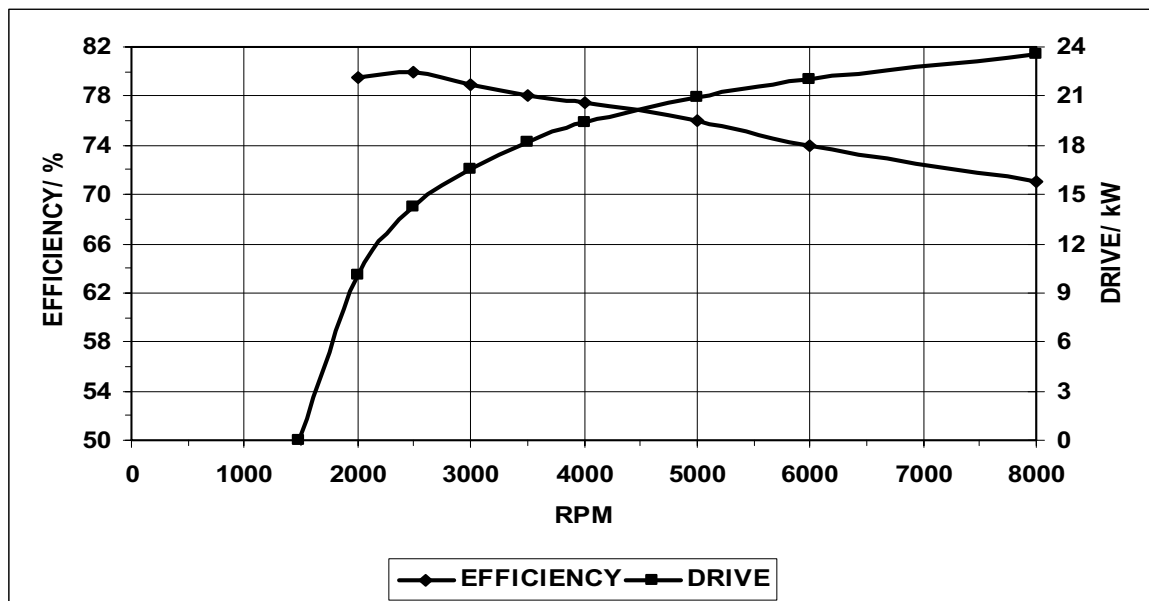

ABBREVIATIONS:

RPM REVOLUTIONS PER MINUTE

kW KILOWATTS (1000 WATTS)

Conversion: 1 kW = 1.341 horsepower (HP)



C.E. Niehoff & Co.
BRUSHLESS ALTERNATORS

N1611
28V 570A

DESIGNING FOR TOMORROW'S DEMANDS

ALTERNATOR CHARACTERISTICS FOR 28 VOLTS/ 570 AMPS:

APPLICABLE MODELS: N1611

SPECIFICATIONS:

- 570 AMPERE 28 VOLTS NEGATIVE GROUND ALTERNATOR SYSTEM
- BRUSHLESS (6) PHASE SELF-ENERGIZING AND SELF-RECTIFYING
- USES EXTERNAL SOLID STATE VOLTAGE REGULATOR
- AMBIENT OPERATING TEMPERATURE: -54 °C/-65°F TO 93°C/200°F
- BI-DIRECTIONAL ROTATION
- SEALED BEARINGS: FRONT 306 BALL; REAR 206 BALL
- UNIT WEIGHT 51 kg/ 112 LBS
- ROTOR INERTIA WITH FAN 468 kg cm²/ 160 LB IN² (BY WEIGHT)
- MAXIMUM SPEED 8000 RPM
- PEAK TORQUE AT 22 °C/72°F MACHINE TEMPERATURE IS 60.1 Nm AT 2500 RPM AND A 453 AMPERE LOAD AT 28.0 VOLTS
- PEAK DRIVE REQUIREMENTS AT 22 °C/72°F MACHINE TEMPERATURE IS 25.4 kW AT 8000 RPM AND A 658 AMPERE LOAD AT 28.0 VOLTS

Headquarters

C. E. Niehoff & Co.
2021 Lee Street
Evanston, IL 60202 USA
Phone: 847/866-6030
Fax: 847/492-1242
E-mail: sales@CENiehoff.com

European Office

C. E. Niehoff & Co., Ltd.
No. 7 Peregrine Place, Moss Side, Leyland,
Preston PR25 3EY United Kingdom
Phone: 44/1772-459777
Fax: 44/1772-624666
Email: info@Niehoff.co.uk



C.E. Niehoff & Co.
BRUSHLESS ALTERNATORS

www.CENiehoff.com