



SEAL Carrier

Technical Specification





Designed, manufactured, delivered and supported
by JFD's defence division.

INTRODUCTION

The primary function of all vehicles within The SEAL Pod range is to facilitate the insertion and extraction of Special Operations forces and their equipment.

SEAL Carrier is a hybrid surface and sub-surface craft which combines the Swedish commitment to safety-led design and the ship-building heritage of the Clyde; all underpinned by a unique operational pedigree of over 30 years.

This document contains further details about SEAL Carrier in a typical configuration. For more information about SEAL Carrier, other vehicles in The SEAL Pod range, or for information about bespoke vehicles, please do not hesitate to contact us.

CONTENTS

Overview	5
Concept of Operations	6 - 7
Operating Modes	8 - 9
Logistics, Insertion & Extraction	10
Operation	11
Vehicle Configuration	12
Optronics & Communication	14
SINC System	15
Construction	16
Procurement Models	16
Additional Information	17
Related Products & Services	18
The SEAL Pod	19
Breathing with Divex	20
Training	21
Dry Deck Shelter Integration	21
Launch & Recovery Systems	22
Maintenance & Support	23
Vehicle Demonstrations	23

SEAL CARRIER OVERVIEW

SEAL Carrier is an 8-man Swimmer Delivery Vehicle designed for the covert insertion and extraction of combat diver units.

The sophisticated interplay between the constituent systems, not least the two propulsion systems, enables the vehicle to operate in three modes: surface-mode, semi-submerged mode, and submerged mode.

SEAL Carrier allows for long range insertion and extraction via the combined use of surface and semi-submerged modes. If an increased risk of detection is identified, the craft can quickly transition from surface to submerged mode in order to reduce its signature further. The transition between the modes is done seamlessly, with no change in pilot handling or disruption in forward speed.

During the approach to the Area of Operation, SEAL Carrier remains fully submerged to remain undetected. Once at the target, with the divers deployed, the SEAL Carrier may be cached on the sea-bed for extraction at a later time.

Onboard sensors and navigation systems work together to provide safe transit and accurate positioning day and night, above or below the surface of the water, regardless of vehicle speed or environmental conditions.

In addition to divers and their personal equipment, SEAL Carrier accommodates additional mission equipment such as sensor- and radio equipment, ammunition and explosives, survival equipment and supplies. For operations requiring extended range, the craft can carry additional fuel stored in a separate fuel tank or additional battery packs.

Specification

Dimensions	
Length	10.45 m
Beam	2.21 m
Height to top of cabin	1.65 m
Height to top of activated snorkel	2.65 m
Max draught fully loaded	0.5 m
Weight	4,000 kg
Crew (Max)	2 pilot + 6 divers
Diesel Engine	257 kW (350 hp)
Fuel capacity (installed bag)	360 l (300 kg)
Thrusters	2 x 10 kW
Battery pack (basic system)	LiPo (38 kWh)
Semi-submerged to 10 m depth	30 s
Breaking surface to 25 kts	150 s
Semi-submerged to 25 kts	120 s



CONCEPT OF OPERATIONS

1 Deployment

The SEAL Air Delivery System allows SEAL Carrier to be deployed from transport aircraft via low-level extraction drop. A medium-lift helicopter may also be used for low-altitude deployment and recovery.

2 Air-Drop

On the surface, SEAL Carrier is quickly released from her deployment frame and the crew embark for rapid surface transit.

For more information about deployment and recovery options, see page 10

3 Surface Mode

In surface mode, SEAL Carrier travels at speeds in excess of 30 knots for up to 150 nautical miles, or 300 nautical miles with an optional secondary fuel bag.

For more information about surface mode, see page 8



4 Semi-submerged Mode

If an increased risk is detected, SEAL Carrier can seamlessly transition to Semi-Submerged mode for a much reduced signature.

For more information, see page 8

5 Submerged Mode

Upon final approach to the target, or in situations where maximum stealth is required, SEAL Carrier dives to depths of 40 - 50 m. In submerged mode, SEAL Carrier can travel for upto 15 nautical miles at speeds upto 3 knots.

For more information, see page 9

6 Vehicle Caching

At the target, SEAL Carrier may be cached for the crew to return to at the end of their mission, or for extraction at a later time.

Alternatively, the Pilot and Navigator may stay with the vehicle to provide mission support, or for withdrawal and extraction.

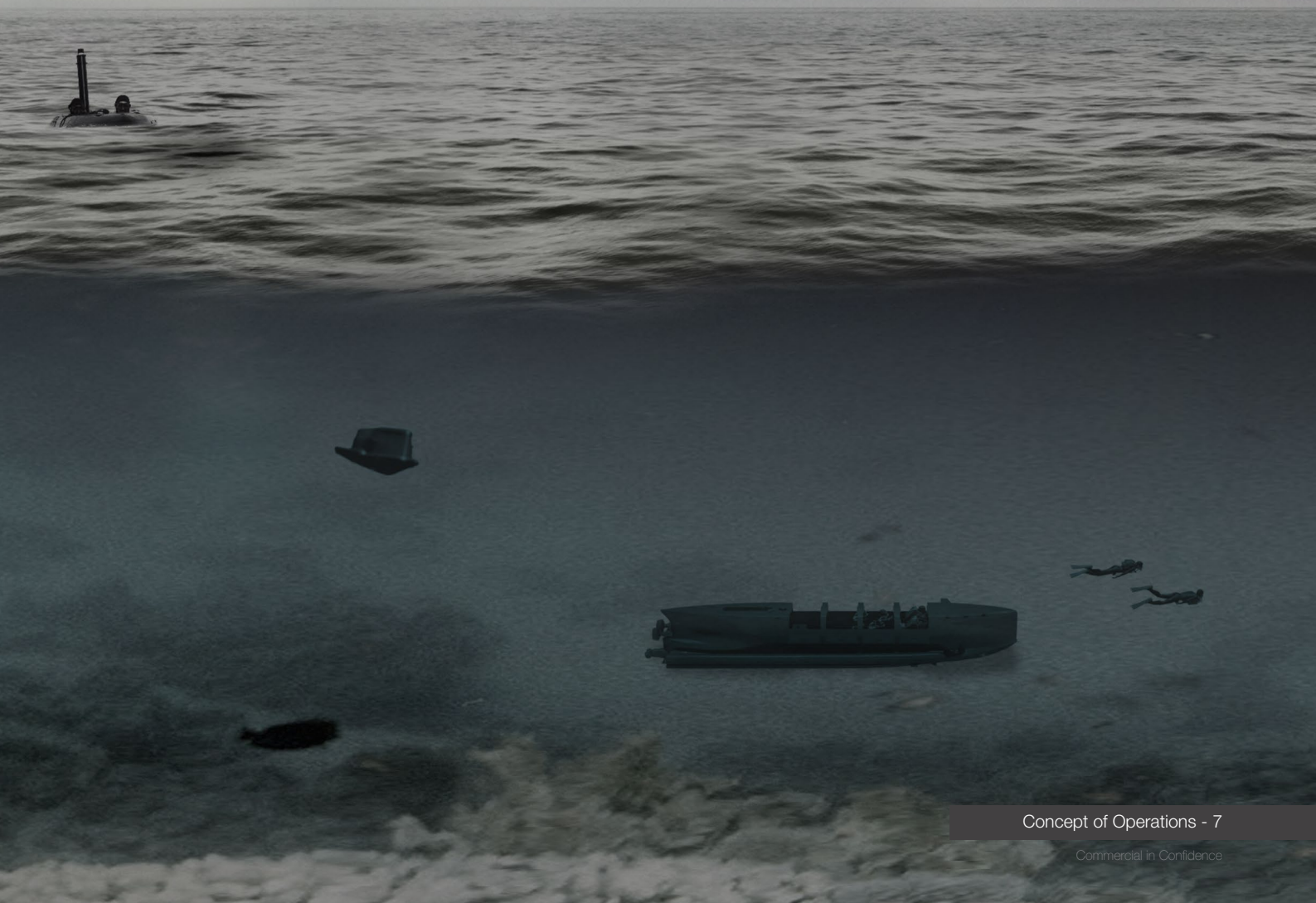



SURFACE MODE

As illustrated in the Concept of Operation, SEAL Carrier operates in three different modes, offering an ideal balance between range & endurance and mission flexibility.

In surface mode, SEAL Carrier is propelled by a water-cooled, 345 horse power diesel engine coupled with a Rolls Royce water jet. Together they allow for perfect manoeuvrability. The nozzle of the water jet is controlled hydraulically and is independent of the other hydraulic systems onboard. A reversing gear is supplied.

Diesel fuel is contained within a 360 litre bag located forward of the engine compartment. A second, additional fuel bag may be fitted to provide SEAL Carrier with increased range of up to 300 nautical miles.

Surface Propulsion	
Diesel Engine Make & Model	VM Motori, MR706LX
Power Output (3800 rpm)	257 kW (345 hp)
Torque (2600 rpm)	700 Nm
Weight	460 kg (dry)
Oil volume	12 L
Cooling water volume	18 L
Generator	
main batteries	48 V 50 A
starter battery	12V 100 A
Reversing gear	ZF-63
Water jet Make & Model	Rolls Royce FF 270

SEMI-SUBMERGED MODE

To reduce the visible, acoustic and radar signature of SEAL Carrier, the vehicle can be operated in semi-submerged mode.

In this mode, the diesel engine and water-jet remain the propulsion system of choice and can propel the craft at sprint speeds of up to six knots. The vehicle's typical cruise speed in this mode is four knots.

The electrical propulsion system - typically reserved for use in submerged mode - made be used if required.

Air intake is achieved via a hydraulically actuated snorkel. The navigator may raise the height of the snorkel by up to a meter so as to avoid water ingress. Sensors within the snorkel seal the engine capsule and prevent the diesel engine from starting if the presence of water is detected within the air inlet system. When not in use, and in surface mode, the snorkel sits flush to the superstructure.



SUBMERGED MODE

The surface propulsion system is contained within a stainless steel casing maintained at a constant pressure. This allows SEAL Carrier to transition into submerged mode seamlessly.

Whilst operating in surface- and semi-submerged modes, the diesel engine and onboard generator charge the Lithium Polymer batteries.

In submerged mode these batteries deliver power to two electric thrusters installed at the vehicle's transom. This propulsion system affords SEAL Carrier a submerged range of 15 nautical miles at a speed of up to five knots. SEAL Carrier's typical cruise speed in submerged mode is three knots.

Additional battery packs may be installed to provide twice the range and endurance in fully-submerged mode.

Built In Breathing System (BIBS)

Regulators are provided to each diver, including pilots, and are fed from an 80 litre 300 bar bottle located beneath the payload compartment.

The system can also be connected to the divers' ordinary regulators if the existing equipment allows.

Safety Installations

Extensive installations are provided to ensure personnel and asset safety, details are provided in the table opposite

Performance

Max. Surface Speed	30 kts+
Speed at full payload	
surface	30 kts
semi-submerged	6 kts
submerged	5 kts
Range	
diesel-driven, surface, cruising, 25 kts	150 Nm+150 Nm
diesel-driven, semi-submerged, 4 kts	150 Nm
electrical, semi-submerged, 3 kts	15 Nm
electrical, submerged, 3 kts	15 Nm
Operating depth	50 m
Payload (crew + cargo)	1,200 kg
Transition between modes	
25 kts surface speed to 10 m depth	150 s
semi-submerged to 10 m depth	30 s
breaking surface to 25 kts	150 s
semi-submerged to 25 kts	120 s

LOGISTICS, INSERTION & EXTRACTION

Logistics

In preparation for a mission, SEAL Carrier can be deployed anywhere in the world within a 40' High Cube ISO container. This makes logistics by road, rail or ship as simple as possible. Within the container, SEAL Carrier sits upon a lightweight launching trailer which, if required, can be used to deploy the vehicle using a harbour slip-way.



SEAL Carrier has been designed to offer maximum flexibility regarding deployment options. Dependant on mission specific requirements, SEAL Carrier can be deployed via a variety of host platforms:

Surface Ship

Using a suitable launch and recovery system, such as an onboard crane, davit, A-frame or moon pool arrangement, the SEAL Carrier can be deployed and recovered to a ship or other surface vessel with full payload and personnel embarked. SEAL Carrier may also be towed behind a surface vessel at 30 knots.

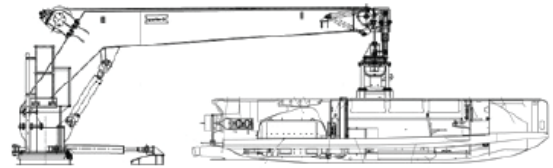

JFD can provide and integrate a variety of launch and recovery systems to meet specific customer and vessel requirements.

Airdrop

SEAL Carrier can be air dropped via the use of the SEAL Air Delivery System. Its aluminium transport frame provides support for the vehicle's superstructure and enables swift and simple handling inside the aircraft.

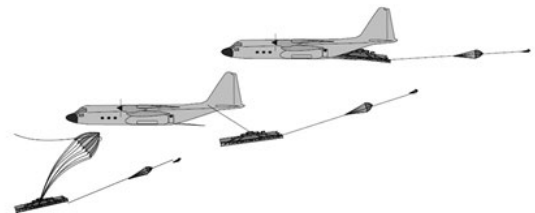

The frame is used in conjunction with the established clustered-canopy extraction-drop method to ensure the correct descent ratio.

Submarine Casing

Generally mounted behind the fin, the SEAL Carrier can be transported on a submarine in wet conditions at depth.



JFD can provide the necessary interfaces and fairings to ensure a hydrodynamic performance is not affected and SEAL Carrier remains securely fixed.

OPERATION

Piloting

The physical design of SEAL Carrier and the computer supported management systems make it very easy and intuitive for the pilots to manoeuvre the craft regardless of mode. This allows the pilots to devote their full attention to the mission, rather than the manoeuvring of the craft.

The Pilot sits on the port side of the craft with logically placed controls ahead of him. The dead man's switch is located next to the steering wheel in front of him, and the Navigator to his right.



Ballast, Trim & Levelling

Two ballast tanks are installed in the bow and aft, totalling 850 litres. On the surface, they are filled with air and provide buoyancy and stability respectively. In submerged mode they are filled with water.

The trim and levelling installation consists of pressure-tight enclosures with sufficient volume to change the buoyancy and to compensate for differences in salinity and payload. Each cylinder has a volume of 75 litres.

Management of the Ballast Trim and Levelling is controlled by the onboard computer system, SINC.

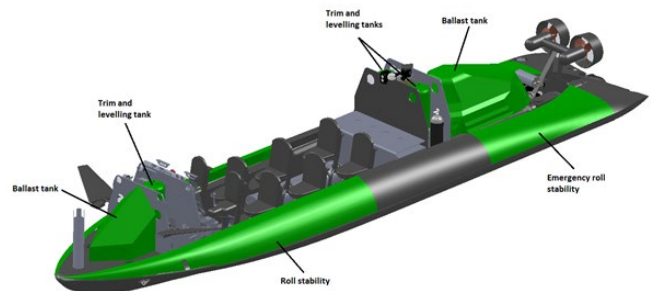

Air System

The air used for the ballast tanks and the sideways roll stability tanks is provided by a 50 litre 300 bar cylinder installed in the keel strake under the main payload compartment.

The emergency lift bag is supplied by two ten litre 300 bar cylinders located behind the payload compartment.

Hydraulic System

The SEAL Carrier's hydraulic system is powered by two electrically driven hydraulic pumps, one 12V and one 48V. When the diesel engine is running - in surface and semi-submerged modes - the 12V pump is used as the primary pump with the other acting as support. When the diesel engine is off - i.e. in submerged mode - the 48V pump becomes primary.

The hydraulic oil tank is positioned in the aft of the engine capsule. Mounted on the tank are the electrical hydraulic pumps, return circuit filter and one control pod.

VEHICLE CONFIGURATION

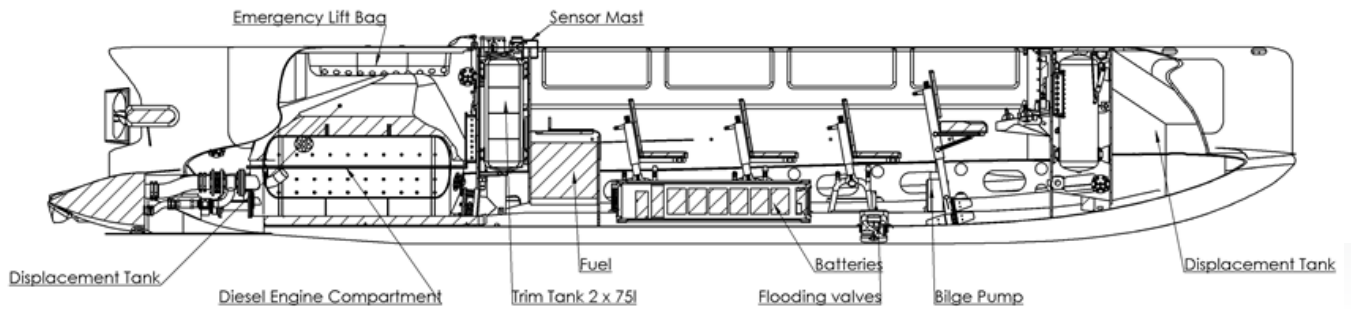

Pilot & Navigator Compartment

The pilot compartment is a self-contained module which includes both the pilot and co-pilot seats. All SINC functions (see page 15) are displayed and controlled from this location.

The pilot sits on the port side of the craft. The dead man's switch is located next to the steering wheel in front of him.



Payload Compartment - Personnel

The payload compartment is fitted, as standard, with six suspension seats suitable for fully out-fitted combat divers.

The cabin is designed in such a way that the transported troops can operate their personal weapons in a functional way from their respective seat.

Additional equipment and assets can also be stored within the casing on either side of the Payload Compartment.

The Carbon Fibre superstructure gives the divers protection from water flow. Large hatches provide the craft with excellent accessibility for maintenance. Hatches in the cabin allow easy embarking and emergency evacuation of personnel in the submerged mode.

Additional Space

In the rear part of the compartment there is room for cargo or one more diver.



OPTRONICS & COMMUNICATIONS

Optronics Mast

An optronic sensor module is installed on top of an ascendable mast. The module is capable of pan and tilt, and consists of a long wave thermal imaging camera, a colour TV camera, a GPS system and a 360° white navigation light.

The module can be controlled via a handheld work station by any one of the six divers in the payload compartment. The work station incorporates a display, a track ball and control switches.



Surface Comms

Where a VHF system has been integrated with SINC, the radio would be fitted inside a subsea housing mounted on the mast for use when SEAL Carrier is in surface mode. The radio would be connected to a 1 m MA 2-1 SC Antenna.

Underwater Comms

Internal alert panels are installed in order to keep each diver informed at the ongoing operation by optical signals and to limit acoustic transmission at critical operational phases.

SEAL Carrier can be equipped with internal voice communication systems. Each diver is provided with a transmitter, bone speaker and microphone. The microphone and bone speaker are adjusted to the diver's personal diving gear.

JFD can also provide SEAL Carrier with fully-wired internal communications systems in order to eliminate the signature associated with through-water transmission.

Navigation Lights

Navigation lights are provided to meet the IMO regulation, comprising masthead, side and stern lights. The installation is fitted on a telescopic mast and the side lights are mounted in the bow.



SINC SYSTEM

The Steering, Information, Navigation and Communications (SINC) system is common to all vehicles in The SEAL Pod range.

The system is modular and can be adjusted, updated and configured to suit a particular mission profile or vehicle configuration.



Navigation

SINC combines data from the GPS, compass, echo sounder, DVL, inertia system, sonar and more to provide accurate navigation in all modes.

System Status

The Pilot and Navigator can monitor the status of all major vehicle systems, in real-time, through the SINC system.

Communications

SINC is compatible with radio and through-water voice and data equipment allowing, inter-team and long-range comms.

Bouyancy Control

SINC monitors water salinity and manages SEAL Carrier's bouyancy automatically in response.

Data Logging

For post-mission analysis, SINC monitors and records all data collected by the onboard computers.

Optronics (ISAR)

SINC is used to deploy the ascendable mast and may be used to control the optronics payload system.

CONSTRUCTION

Construction Standards

The design and construction of SEAL Carrier complies with the following documents:

- ✓ Swedish Armed Forces Naval Regulations as stated in RMS.
- ✓ Hull structure is built in accordance with DNV rules for classification of High Speed, Light Craft and Naval Surface Craft and DNV standard for certification No. 2.21 Craft.
- ✓ System safety documentation issued by JFD Sweden.

Hull Construction

The hull is a single skin construction in Carbon Fibre reinforced epoxy. The keel strake is reinforced and prepared for beaching operations.

The inside of the hull is bare to provide a sufficient water flow to facilitate transfer between the three modes. Hydraulically operated valves are located in the bottom, to flood the craft, and in the transom, for drainage.

Superstructure

The superstructure of SEAL Carrier is made with Carbon Fibre, allowing for a lightweight, streamlined body. It includes all equipment and gives the divers protection from the water flow. Large hatches provide the craft with excellent accessibility for maintenance. Hatches in the cabin allow easy embarkation and emergency evacuation of personnel when travelling in submerged mode.

PROCUREMENT MODELS

JFD recognises that different nations have different preferences when it comes to procuring new capabilities.

In all instances, an Export Licence is required.

Outright Purchase

Established equipment procurement route with options for two- or three-year parts only warranty periods.

Pros:

- ✓ Traditional procurement route
- ✓ Customer owns equipment
- ✓ Customer may tender for support

Cons:

- ✗ One-off capital expenditure
- ✗ Customer responsible for through-life costs
- ✗ Customer responsible for asset availability

Purchase & Support

As per outright purchase, plus an additional support contract to cover both planned and unplanned maintenance activities.

Pros:

- ✓ Assets maintained to OEM standards
- ✓ Short maintenance turnaround times
- ✓ Guaranteed spares availability

Cons:

- ✗ One-off capital expenditure
- ✗ Customer responsible for through-life costs, and all repair costs & associated downtime.

Contract for Capability

A fixed monthly fee in exchange for a fully managed capability, with agreed levels of availability year round.

Pros:

- ✓ No up front costs
- ✓ Guaranteed availability of assets
- ✓ Risk borne by JFD, not Customer
- ✓ Agreed repair arrangements

Cons:

- ✗ Non-traditional procurement method
- ✗ Minimum contract duration required

ADDITIONAL INFORMATION

Onboard Hardware, enclosed in pressure proof cans where necessary

Anchor, chain and nylon warp

Mooring warps

Onboard tool kit

Handheld fire extinguisher

Distress signal kit

Sensor Suite

Echo sounder

Sonar

Water temperature meter

Depth meter

Doppler Velocity Log

TV & IR Camera

Battery Monitoring System

Additional Equipment, installed in an ISO 40ft high cube container

Trailer, light launching trailer

Charger for both battery systems

Compressor for air systems, with the capacity of 265 l/min

Diesel fuel unit

Spare part kit

Tool kit

First aid kit

Lifting slings

Log Explorer software for post mission data analyse, such as

Tank levels

Dive depths

Route analysis

Diesel fuel consumption

Documentation & Manuals

- ✓ A Boat Manual comprising the Operating Manual, the Maintenance Manual, the Servicing Schedule and the Parts List
- ✓ Technical Manual including Drawings and Certificates
- ✓ System Safety Document
- ✓ Construction Rule Documentation

Super SeaKing Sonar Specification

	High Frequency	Low Frequency
Operating Frequency	CHIRP centred on 650 kHz	CHIRP centred on 325 kHz
Beam width	40° Vertical, 1.5° Horizontal	20° Vertical, 3.0° Horizontal
Pulse Length	200 µs	400 µs
Maximum Range	100 m	300 m
Minimum Range	0.4 m	
Range Resolution	Approximately 15mm (minimum)	
Mechanical Resolution	0.45° , 0.9° , 1.8° , 3.6°	
Source Level	210 dB re 1 µPa at 1 meter	
Scanned Sector	Variable up to 360°	
Continuous 360° Scan	Yes	
Sector Offset Mode	Yes	

Software

PC-based planning software is provided. Route information may be uploaded to the SINC System prior to commencement of the mission.

Log Explorer software is provided to enable review and analysis of SEAL Carrier log files.



RELATED EQUIPMENT & SERVICES

THE SEAL POD



Torpedo SEAL

Torpedo SEAL transits within a NATO-standard 533 mm torpedo tube. Once removed from the tube, Torpedo SEAL is fully extended and ready for use.

It is then able to transport two divers and equipment, fully submerged, over a range of 10 nautical miles at a maximum speed of four knots.

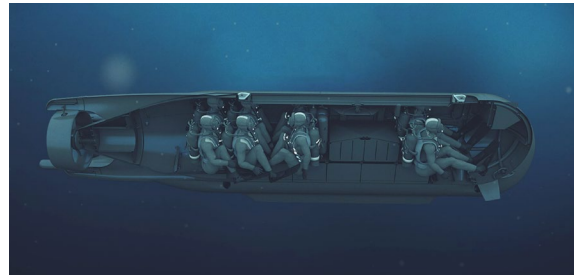

Sub SEAL

Sub SEAL vehicles are primarily launched from a hangar attached to the casing of a submarine, and are released whilst fully submerged, at depths of up to 30 m. Once launched, Sub SEAL remains submerged for the entire mission. The vehicles may approach, or break, the surface for communication or reconnaissance purposes.

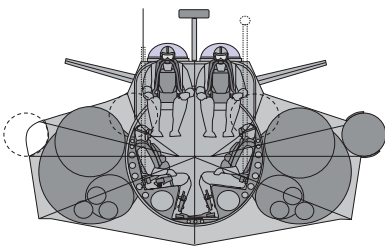

SEAL Lion

SEAL Lion is suited to mission profiles demanding greater range, endurance and payload capacity.

The craft accommodates three crew and 16 marines and their equipment in stealth and dry conditions during the final semi-submerged phase of a landing operation.

BREATHING WITH DIVEX

JFD'S Divex-brand rebreathers integrate seamlessly with The SEAL Pod.

JFD provides a comprehensive range of Divex defence diving apparatus, apparel and ancillaries to meet the varied requirements and operational demands of today's Special Operations Diver. A range of low magnetic and acoustic, Closed and Semi-Closed oxygen and mixed gas rebreathers can be tailor made to user specification.

Divex breathing equipment and diver monitoring systems can be integrated with SEAL Pod vehicles. A selection of equipment complimentary to



Shadow Enforcer

Underwater Breathing Apparatus

Shadow Enforcer is a new generation of shallow water UBA designed to meet the roles of the combatant diver.

Stealth CDLSE

Clearance Divers Life Support Equipment

Part of the operationally proven range of Stealth Closed Circuit Mixed Gas Underwater Breathing Apparatus (CC UBA).



Shadow & Shadow Excursion

Underwater Breathing Apparatus

Designed to meet the evolving operational roles of maritime law enforcement and special operations.



TRAINING

Vehicle Operations

If required, JFD can provide vehicle operations training for Pilots, Navigators and Passengers. The training can be delivered either in Vaxholm, Sweden, or at a location of the customer's choosing.

Rebreather Operation & Maintenance

JFD and sister company Divex offer practical courses in the set-up, operation and ongoing maintenance of closed and semi-closed circuit rebreather systems.

Lock-in Lock-Out Procedures

JFD is able to provide both theoretical and practical training in the safe conduct of submarine lock-in lock-out operations.

Dry Deck Shelter Operations

JFD's special operations teams offer training courses focused on the safe operational use of DDS facilities.



DRY DECK SHELTER INTEGRATION

The integration of SEAL vehicles with either a new-build or existing Dry Deck Shelter greatly increases the overall range and effectiveness of a modern Special Forces capability.

Maintenance, mission configuration and preparation all take place at one atmosphere inside the DDS during the transit phases to, and from, the area of operation.

For information about how JFD can assist in the development of this advanced capability, please contact us.



LAUNCH & RECOVERY SYSTEMS

JFD has a 30+ year history of safely launching and recovering submersible vehicles at sea, in challenging conditions, across the world.

JFD, and partner Caley Ocean Systems, can provide the following launch & recovery systems for each of the vehicles in the SEAL Pod.

The options shown here illustrate the breadth of our joint expertise. Each solution may be further customised for specific requirements including, for example, low-magnetic signature platforms.

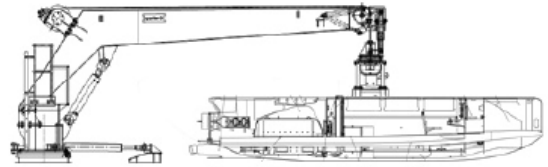

Cranes & Davits

Cranes or davits offer simple, rapidly mobilised, launch & recovery solutions suitable for most vessel types.

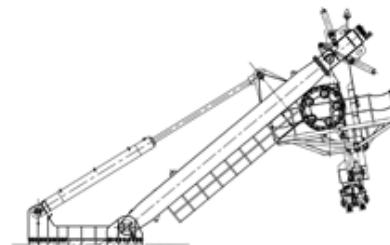

A-Frames

A-Frame launch & recovery systems are suitable for launching larger Sub SEAL vehicles, safely, in higher sea states.

Such systems can be permanently installed or made air-transportable.

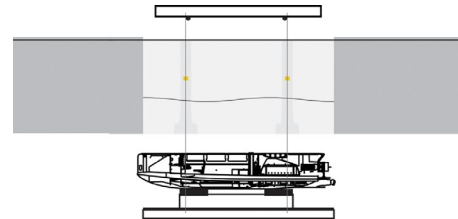

Moon Pool

For those preferring moon pool operations for launch & recovery, JFD can provide suitable methods of deployment for SEAL Pod vehicles.



MAINTENANCE AND SUPPORT

The craft is constructed for a lifetime of 15 years. The maintenance manual is based on the requirement of the installed subsystems and extreme tropical conditions.

A life time support Annual Maintenance Contract (AMC), divided into three periods, is available as an option.

Global Support Network

Sweden is the home of The SEAL Carrier. Our facility in Vaxholm is the engineering and operational hub of our Special Operations activities.

Rapid engineering support for SEAL Carrier vehicles is delivered via JFD's existing global support network. JFD maintains bases in the UK, USA, Singapore, and Australia - alongside a pool of engineers available for rapid call-out worldwide.

Vehicle Demonstrations

JFD can arrange vehicle demonstrations for prospective customers in either Sweden or the United Kingdom. Alternatively, arrangements may be made for demonstrations in locations of a customer's choosing.



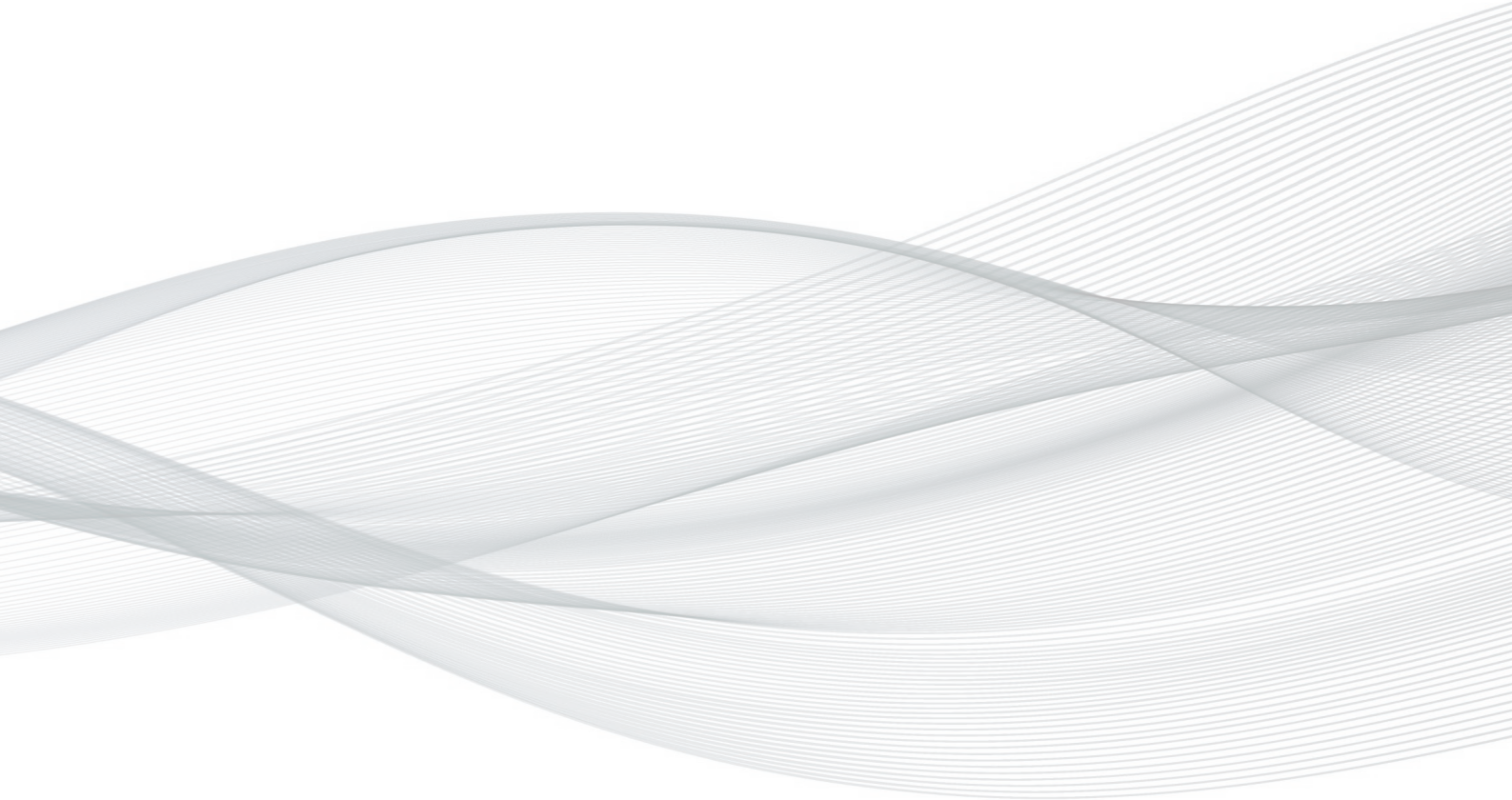

jfdglobal.com

© JFD. All Rights Reserved. Issue 4.