



EXPEDITIONARY FORCE PROTECTION FROM DEFENCELL

Ranger is a shorter version of the proven DEFENCELL LITE with the same strong cellular construction and durable materials. The Ranger is exceptionally lightweight, weighing only 1.4kgs and can be filled in less than ten minutes by hand, however it is the equivalent of over forty sandbags (7kgs+).

Ranger is ideal for firing positions and pop-up target protection, and being completely non-metallic, ensures no risk of ricochet or secondary shrapnel. An optional filling frame can be provided for filling multiple units. The unique open honeycomb structure allows the Ranger to be easily emptied and the units are re-usable and durable. High UV resistance is built into the fabric ensuring longevity of use.

System Characteristics

- Lightweight - 1.4 Kg
- Fast and easy to fill
- Fully tested
- Minimum 2-year field life
- Fill with sand, gravel and rocks
- Fill manually
- Firing positions and pop-up target protection
- Protect critical equipment
- All textile - no inherent secondary fragmentation
- Protect against small arms up to 14.5 mm and 0.5"
- Protect against fragmentation weapons

• In production - contact us for further information and orders

Specifications

NATO Stock Number: 5680-99-285-4166

Model	Height	Width (Footprint)	Width (Protective)	Length	Weight
RANGER	20" (plus 4" skirt)	28"	25"	50"	3.6 lbs
	0.50m (plus 0.10m skirt)	0.70 m	0.63 m	1.30 m	1.60 kgs

DEFENCELL has been extensively tested:

Environmental

- High Temperatures/ Low Temperatures
- Humidity/Contamination by Fluids
- Direct Sunlight/ UV Degradation
- Blowing Sand
- Mildew Fungus / Corrosion Resistance
- Fire Safety Performance

Protection

- Ballistic testing
- Blast Mitigation

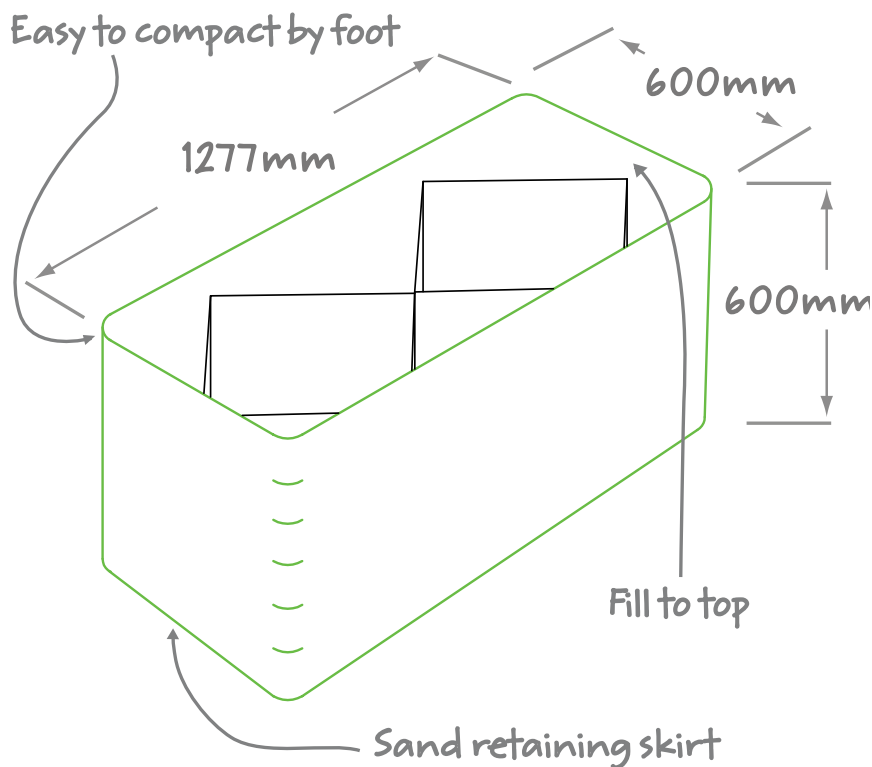

Transportability – Packing & Coverage

	1 section	1 pallet	20' ISO
Quantity of RANGER	1	90	1800
Weight	1.60 kgs	174 kgs	3,480 kgs
Filled Volume	0.47 m ³	42 m ³	840 m ³
Sandbag Equivalent	40	3,600	72,000

© 2012 J&S FRANKLIN LTD. RANGER V2.12.NSN.UK