

CABLE ASSEMBLIES

Line Catalogue

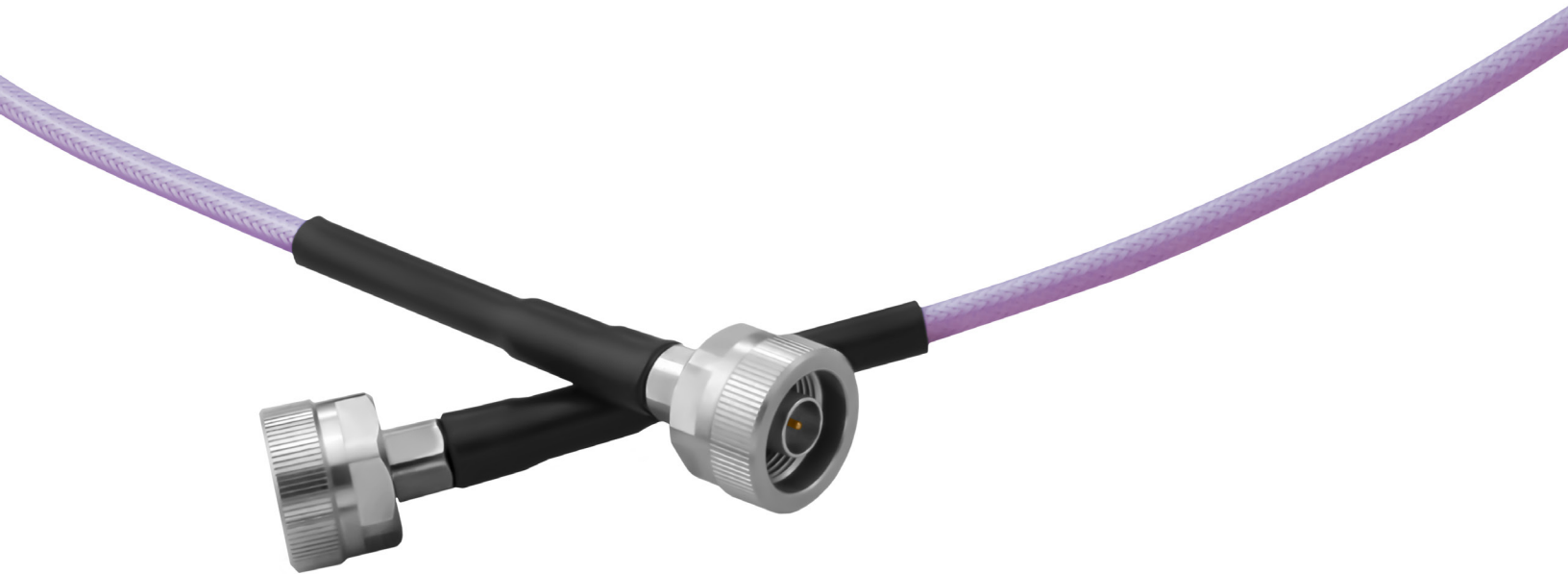

About Smith Interconnect

Smiths Interconnect is a leading provider of technically differentiated electronic components, subsystems, microwave and radio frequency products that connect, protect and control critical applications in the Defence and Aerospace, Communications and Industrial markets.

Our technology brands (EMC, Hypertac, IDI, Lorch, Millitech, Reflex Photonics, RF Labs, Sabritec, TECOM, TRAK and HSI) are synonymous with exceptional performance in technologically advanced, high quality solutions required for a high degree of safety and durability. Our extensive product portfolio includes high reliability electrical connectors and cable assemblies, solutions for antenna systems, and a wide range of innovative RF and microwave solutions.

Smiths Interconnect is part of Smiths Group plc, a global leader in applying advanced technologies for markets in threat and contraband detection, energy, medical devices, communications and engineered components. Smiths Group employs around 22,000 people in more than 50 countries.

Your global partner
for innovative
connectivity
solutions

INDUSTRIAL



COMMUNICATIONS



DEFENCE
& AEROSPACE



We Offer

Technical excellence and broad market experience

A comprehensive product portfolio providing customers with a single point of supply across multiple markets

Advanced engineered solutions integrating the combined expertise of our technology brands to create value for our customers

Optimised quality through first-class materials, state-of-the-art development practices, and world class talent

Robust financial pedigree and reputable heritage of Smiths Group

Technology Brands

EMC

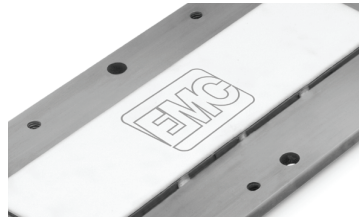

High Reliability RF/Microwave Resistive & Signal Distribution Components

Board-level components incorporating advanced resistive and signal distribution technologies for a broad range of frequency spectrum applications. Extensive portfolio of RF devices used to attenuate, level, or terminate signals available in a variety of packages and footprints.

HYPERTAC

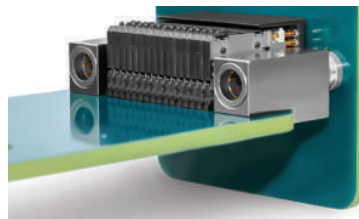

Superior Performing Electrical Connectors for the Most Demanding Applications

Premium interconnect solutions for electrical and electronic applications requiring optimised quality, performance, and reliability. Utilising the original Hypertac hyperboloid contact technology to achieve high performance in harsh environments and safety critical applications.

IDI

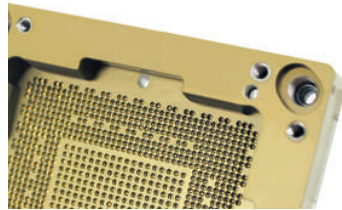

High Density Interconnect & Semiconductor Test Solutions with Spring Probe Technology

World's most comprehensive offering of spring probe based solutions, including: contacts, connectors, interposers, semiconductor test sockets, and ATE interfaces. Proven off-the-shelf and custom products deliver the best solution for the customer's specific application.

LORCH



RF/Microwave Conditioning Products with High Selectivity Using Multiple Topologies

Innovative solutions for the electronics and communications industries. Ranging from high performance wireless and RF products to micro-miniature, cavity, discrete, waveguide, tunable, ceramic, and tubular filters and integrated assemblies.

MILLITECH



Leader in Millimeter-Wave Technology & Product Solutions

Specialising in the engineering, manufacturing, and testing of millimeter-wave components, assemblies, and fully integrated subsystems for space, SATCOM, test and measurement, radar, and scientific applications.

REFLEX
PHOTONICS

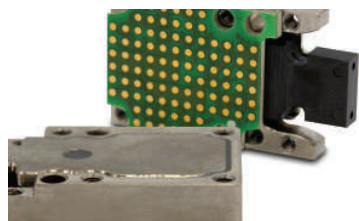

Developer of Rugged, High Speed Optical Transceiver Modules & Parallel Embedded Optics Products

Embedded transceivers and transmit/receive modules for advanced interconnect-based solutions. Targeting high data rate interconnects where ruggedness and radiation resistance are required for defence, space, commercial aerospace and industrial applications.

RF LABS



High Frequency Microwave Cable Assemblies & Coaxial Components

High performance microwave cable assemblies and coaxial components supporting high performance operations, application-specific premium interconnects for high durability and harsh environments.

SABRITEC



High Speed Data and Transient Protection Interconnect Solutions

High speed quadrate, twinax, fibre optic, filter, coax and triax connectors, contacts and cable assemblies. Custom multi-pin circular, D-Sub rack and panel connectors and MIL-Spec interface type products.

TECOM

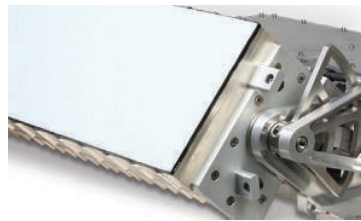

Advanced Antenna Systems & Solutions for RF/Microwave Applications

Industry leading innovator of antennas and positioning systems for SATCOM in-flight connectivity, instrumentation, datalink, command & control, and telemetry applications integrated into the world's most advanced commercial and military platforms.

TRAK



High Reliability RF/Microwave Subsystems & Components

High reliability multi-function RF systems, ferrite microwave products, and precision time & frequency systems for defence, commercial aerospace, space, homeland security, and public safety applications.

HSI



High Reliability Connectors for Commercial Aerospace & Railway

Joint venture with Sichuan Huafeng Enterprise Group Co. Ltd, one of the major manufacturers of electronic components in China. Industry-leading connectivity solutions for commercial aerospace and railway markets in mainland China.

Synonymous with exceptional performance,
safety and durability

Cable Assemblies

Table of Contents

CABLE SELECTION	VII-XVII
Cable By Application.....	VII-IX
Cable By Critical Parameter	X-XI
Cable By Attenuation	XII-XIII
Cable By Power.....	XIV-XV
Cables & Connectors.....	XVI-XVII



Semi-Rigid, Conformable® & Flexible **1-12**

Semi-Rigid, Conformable & Flexible Specifications	2-5
Semi-Rigid, Conformable & Flexible Performance	6
Semi-Rigid, Conformable & Flexible Connector Selection & Options	7
Semi-Rigid, Conformable & Flexible Options & Ordering Information	8
.047 Series	9
.085 Series	10
.141 Series	11
.250 Series	12

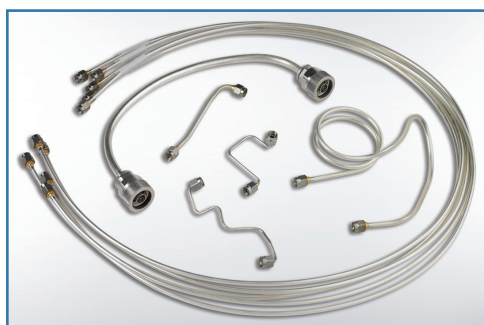

Semi-Rigid Low Loss..... **13-20**

Semi Rigid Low Loss Specifications	14
Semi Rigid Low Loss Performance	15
Semi Rigid Low Loss Connector Selection & Options	16
Semi Rigid Low Loss Ordering Information	17
.085 Low Loss Semi Rigid	18
.141 Low Loss Semi Rigid	19
.250 Low Loss Semi Rigid	20



MIL-C-17 | RG Series **21-28**

MIL-C-17 RG Series Specifications	22-23
MIL-C-17 RG Series Performance	24
MIL-C-17 RG Series Connector Selection & Options	25
MIL-C-17 RG Series Options & Ordering Information	26
Under .150" Diameter Series	27
Over .150" Diameter Series	28



LMR® **29-37**

LMR Specifications	30
LMR Performance	31
LMR Connector Selection & Options	32
LMR Options & Ordering Information	33
100A Series	34
195 Series	35
240 Series	36
400 Series	37

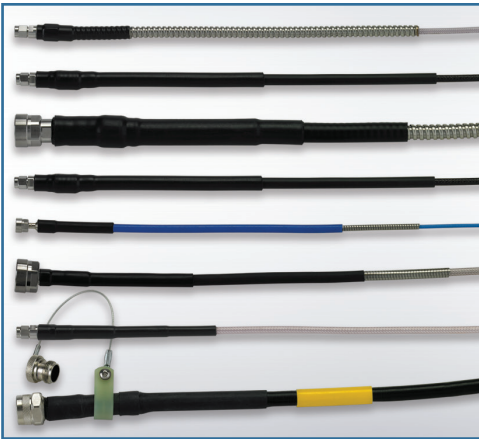

Cable Assembly Options..... 39-49

Option - A (Armorized).....	39
Option - Z (Cable to Connector Waterproof Seal*).....	40
Option - W (Weatherized).....	41
Option - AW (Armorized & Weatherized).....	42
Option - N (Neoprene).....	43
Option - MC (Monocoil).....	44
Option - MP (Armorized Monocoil).....	45
Option - D (Dust Caps).....	46
Option - E (Extended Boots).....	47
Option - ± 2.8 PS (Phase Matched).....	48
Option - RoHS (RoHS Compliant).....	49

Application Notes 51-56

Cable Length Definition and Tolerances	51
Cable Pre-Formed Right Angle.....	52
Connector Product Codes	53-54
Connector Interseries Mating	55
Care and Handling.....	56

Engineering Data 57-58

Phase Stability Temperature	57
Materials Abbreviations	58

Cable Selection Guide

By Application

Max Frequency (GHz)	5.8	10	18	18	18	18	18	18	18	18	18	18
Applications												
2-Way Radio	LMR									CONFORMABLE BJ085		
Antenna Systems		LAB-FLEX 490S			LAB-FLEX 290	LAB-FLEX 335	LAB-FLEX 336SP					
Base Stations	LMR		RG FLEXIBLES <0.150 DIA.	RG FLEXIBLES >0.150 DIA.						CONFORMABLE BJ085	CONFORMABLE BJ141	
Cellular	LMR		RG FLEXIBLES <0.150 DIA.	RG FLEXIBLES >0.150 DIA.						CONFORMABLE BJ085	CONFORMABLE BJ141	
Earth Stations			RG FLEXIBLES <0.150 DIA.									MINI-FLEX 165
Fiber Optic Systems												
Field Test Setups					LAB-FLEX 290	LAB-FLEX 335	LAB-FLEX 336SP					
High Frequency Interconnects									CONFORMABLE BJ047	CONFORMABLE BJ085	CONFORMABLE BJ141	
Instrumentation								SEMI-RIGID 250	CONFORMABLE BJ047	CONFORMABLE BJ085	CONFORMABLE BJ141	MINI-FLEX 165
Interconnects	LMR		RG FLEXIBLES <0.150 DIA.	RG FLEXIBLES >0.150 DIA.						CONFORMABLE BJ085	CONFORMABLE BJ141	
Jumpers	LMR		RG FLEXIBLES <0.150 DIA.					SEMI-RIGID 250	CONFORMABLE BJ047	CONFORMABLE BJ085	CONFORMABLE BJ141	MINI-FLEX 165
Land Mobile	LMR											
Long Run Test Cables		LAB-FLEX 490S			LAB-FLEX 290	LAB-FLEX 335	LAB-FLEX 336SP					
Low Cost, High Frequency Jumpers			RG FLEXIBLES <0.150 DIA.	RG FLEXIBLES >0.150 DIA.					CONFORMABLE BJ047		CONFORMABLE BJ141	
Low Loss Jumpers	LMR											
Military Systems		LAB-FLEX 490S	RG FLEXIBLES <0.150 DIA.	RG FLEXIBLES >0.150 DIA.		LAB-FLEX 335	LAB-FLEX 336SP	SEMI-RIGID 250				MINI-FLEX 165
Mobile Antennas	LMR		RG FLEXIBLES <0.150 DIA.	RG FLEXIBLES >0.150 DIA.	LAB-FLEX 290	LAB-FLEX 335	LAB-FLEX 336SP					
PCS	LMR		RG FLEXIBLES <0.150 DIA.									
Radar Systems		LAB-FLEX 490S	RG FLEXIBLES <0.150 DIA.	RG FLEXIBLES >0.150 DIA.	LAB-FLEX 290		LAB-FLEX 336SP	SEMI-RIGID 250				
Radio Systems			RG FLEXIBLES <0.150 DIA.	RG FLEXIBLES >0.150 DIA.						CONFORMABLE BJ085		
Satcom		LAB-FLEX 490S		RG FLEXIBLES >0.150 DIA.	LAB-FLEX 290	LAB-FLEX 335	LAB-FLEX 336SP	SEMI-RIGID 250				
Satellites			LAB-FLEX 290Q									
Switch Interconnects									CONFORMABLE BJ047	CONFORMABLE BJ085		MINI-FLEX 165
Telecommunications			RG FLEXIBLES <0.150 DIA.	RG FLEXIBLES >0.150 DIA.						CONFORMABLE BJ085	CONFORMABLE BJ141	
Test Cables			RG FLEXIBLES <0.150 DIA.	RG FLEXIBLES >0.150 DIA.						CONFORMABLE BJ085	CONFORMABLE BJ141	
Test Equipment Interconnects												
Test Head Cables												
Test Set Ups												
Wireless Telemetry	LMR									CONFORMABLE BJ085		MINI-FLEX 165

Max Frequency (GHz)	26	32	35	35	40	40	50	50	50	55	60	65
Applications												
2-Way Radio						MINI-FLEX 105						SEMI-RIGID 086
Antenna Systems	LAB-FLEX 235SP	LAB-FLEX 190Q			LAB-FLEX 180SP							
Base Stations												
Cellular												
Earth Stations	LAB-FLEX 235SP		SEMI-RIGID 141		LAB-FLEX 180SP	MINI-FLEX 105						SEMI-RIGID 086
Fiber Optic Systems						LAB-FLEX 160		LAB-FLEX 100		MINI-FLEX 065		
Field Test Setups												
High Frequency Interconnects	LAB-FLEX 235SP			K-JUMPER	LAB-FLEX 180SP	LAB-FLEX 160	LAB-FLEX 125	LAB-FLEX 100			SEMI-RIGID 086	LAB-FLEX 115S
Instrumentation			SEMI-RIGID 141	K-JUMPER		MINI-FLEX 105	LAB-FLEX 125	LAB-FLEX 100		MINI-FLEX 065	SEMI-RIGID 086	LAB-FLEX 115S
Interconnects						MINI-FLEX 105	LAB-FLEX 125				SEMI-RIGID 086	
Jumpers			SEMI-RIGID 141	K-JUMPER		MINI-FLEX 105		LAB-FLEX 100		MINI-FLEX 065	SEMI-RIGID 086	
Land Mobile												
Long Run Test Cables												
Low Cost, High Frequency Jumpers				K-JUMPER				LAB-FLEX 100		MINI-FLEX 065		
Low Loss Jumpers								LAB-FLEX 100		MINI-FLEX 065		LAB-FLEX 115S
Military Systems	LAB-FLEX 235SP	LAB-FLEX 190Q	SEMI-RIGID 141		LAB-FLEX 180SP	LAB-FLEX 160					SEMI-RIGID 086	
Mobile Antennas	LAB-FLEX 235SP	LAB-FLEX 190Q										
PCS												
Radar Systems	LAB-FLEX 235SP	LAB-FLEX 190Q			LAB-FLEX 180SP	LAB-FLEX 160					SEMI-RIGID 086	
Radio Systems						MINI-FLEX 105						
Satcom	LAB-FLEX 235SP	LAB-FLEX 190Q			LAB-FLEX 180SP						SEMI-RIGID 086	
Satellites			SEMI-RIGID 141	LAB-FLEX 160Q	LAB-FLEX 160Q	LAB-FLEX 105Q					SEMI-RIGID 086	
Switch Interconnects						LAB-FLEX 160	LAB-FLEX 125	LAB-FLEX 100		MINI-FLEX 065	SEMI-RIGID 086	
Telecommunications						MINI-FLEX 105					SEMI-RIGID 086	
Test Cables	LAB-FLEX 235SP	LAB-FLEX 190Q	SEMI-RIGID 141	K-JUMPER	LAB-FLEX 180SP	LAB-FLEX 160	LAB-FLEX 125	LAB-FLEX 100			SEMI-RIGID 086	LAB-FLEX 115S
Test Equipment Interconnects	LAB-FLEX 235SP	LAB-FLEX 190Q				LAB-FLEX 160	LAB-FLEX 125					LAB-FLEX 115S
Test Head Cables	LAB-FLEX 235SP	LAB-FLEX 190Q				LAB-FLEX 160	LAB-FLEX 125	LAB-FLEX 100				LAB-FLEX 115S
Test Set Ups	LAB-FLEX 235SP	LAB-FLEX 190Q				LAB-FLEX 160	LAB-FLEX 125					
Wireless Telemetry												

Cable Selection Guide

By Critical Parameter

Max Frequency (GHz)	2.5	18	30
Insertion Loss			
Extremely Low	LMR 400		
Very Low	Lab-Flex 290, 335, 490S	Lab-Flex 290, 335	
Low	Lab-Flex 335SP, 200, 160, LMR 240	Lab-Flex 335SP, 200, 160	Lab-Flex 200, 160
Average	Lab-Flex 125, 235SP, 180SP, SF142	Lab-Flex 125, 235SP, 180SP, SF142	Lab-Flex 125, 180SP
High	RG142, BJ141, RG402, K-Jumper, Mini-Flex 165, 100	RG142, Lab-Flex 100	Lab-Flex 100
Very High	RG405, TF405, BJ085, SF316, Mini-Flex 105, 115S	RG405, Mini-Flex 105, BJ085, SF316, 115S	RG405, 115S, Mini-Flex 105
Extremely High	142D & 316D, RG316, Mini-Flex 065	142D Ultraflex, Mini-Flex 065	Mini-Flex 105
Harsh Environments			
Best	All Lab-Flex S Series with AW Option, All Lab-Flex AF	All Lab-Flex & Lab-Flex S Series with AW Option, All Lab-Flex AF	Lab-Flex 160AW, 200AW, 180AW, Lab-Flex 160AF
Better	LMR 240DB, LMR 400DB		
Good	All Lab-Flex Weatherized Series	All Lab-Flex Weatherized Series	Lab-Flex 125W, 160W, 200W, 180SPW
Fair	SF316, 100, All Mini-Flex	TF402, TF405, SF316, 100, Mini-Flex 065 & Mini-Flex 065	Lab-Flex 100, Mini-Flex 065 & Mini-Flex 105
Fair	RG142, RG400, RG316, RD316	RG142	
Not Recommended	BJ141, BJ085, K-Jumper, RG223, 142D & 316D Ultraflex	BJ141, BJ085, K-Jumper	
Flexibility			
Best	142D & 316D Ultraflex, Mini-Flex 065	142D Ultraflex, Mini-Flex 065	Mini-Flex 065
Better	RG316, RD316, SF316, 115S, 180SP, Mini-Flex 105	SF316, TF405, 100, 125, Mini-Flex 105	Lab-Flex 100, 125, Mini-Flex 105
Good	RG142, RG400, RG223, 235SP, 335SP, Lab-Flex 160	RG142, 235SP, 335SP, Lab-Flex 160	Lab-Flex 160
Fair	Lab-Flex Series, SF 142, Mini-Flex 165	Lab-Flex Series, SF142, Mini-Flex 165	Lab-Flex 200, Mini-Flex 165
Limited	BJ141, BJ085, K-Jumper, 490S	BJ141, BJ085, K-Jumper	K-Jumper
Phase Stability over Temperature			
Better	AL085LLSP, AL141LLSP, AL250LLTP	AL085LLSP, AL141LLSP, AL250LLTP	AL085LLSP, AL141LLSP
Good	LMR Series		
Good	All Lab-Flex & Lab-Flex S	All Lab-Flex & Lab-Flex S	Lab-Flex 100, 125, 160, 200, 115S, 180SP
Fair	BJ085, BJ141, K-Jumper, Mini-Flex	BJ085, BJ141, K-Jumper, Mini-Flex	K-Jumper, Mini-Flex 065 & Mini-Flex 105
Poor	Solid Dielectric Flexible	Solid Dielectric Flexible	
Poor	Solid Dielectric Semi-Rigid	Solid Dielectric Semi-Rigid	Solid Dielectric Semi-Rigid

Max Frequency (GHz)	40	50
Insertion Loss		
Extremely Low		
Very Low		
Low	Lab-Flex 160	
Average	Lab-Flex 125, 180SP	Lab-Flex 125
High	Lab-Flex 100	Lab-Flex 100
Very High	RG405, 115S, Mini-Flex 105	RG405, 115S, Mini-Flex 105
Extremely High	Mini-Flex 065	Mini-Flex 065
Harsh Environments		
Best	Lab-Flex 160AW, 180SP, Lab-Flex 160AF	
Better		
Good	Lab-Flex 125W, 160W, 180SPW	Lab-Flex 125W
Fair	Lab-Flex 100, Mini-Flex 065 & Mini-Flex 105	Lab-Flex 100, Mini-Flex 065
Fair		
Not Recommended		
Flexibility		
Best	Mini-Flex 065	Mini-Flex 065
Better	Lab-Flex 100, 125, Mini-Flex 105	Lab-Flex 100 & 125
Good	Lab-Flex 160	
Fair		
Limited		
Phase Stability over Temperature		
Better	AL085LLSP	AL085LLSP
Good		
Good	Lab-Flex 100, 125, 160, 115S, 180SP	Lab-Flex 100, 125, 115S
Fair	Mini-Flex 065 & Mini-Flex 105	Mini-Flex 065
Poor		
Poor	Solid Dielectric Semi-Rigid	Solid Dielectric Semi-Rigid

Cable Selection Guide

By Attenuation (dB per 100 feet)

BAND Frequency (GHz)	L		S		C				X				Ku						K								
	1	2	3	4	5	6	7	8	9	10	11	12	13	14	15	16	17	18	19	20	21	22	23	24	25	26	
Semi-Rigid, Low-Loss																											
AL250LLTP		7.0		10.0				14.2				17.6						21.8		34.0							
AL141LLSP		15.9		22.8				32.9				40.8						50.9									62.4
AL085LLSP		28.3		40.3				57.6				71.2						88.1									107.0
Semi-Rigid, Conformable (BJ), Flexible (Mini-Flex)																											
RG401 (.250 S/R)		10.4		16.1				25.5				33.9						45.5									
250TP		10.4		16.1				25.5				33.9						45.5									
Mini-Flex 165		17.2		25.7				39.1				50.6						65.9									
K-Jumper		17.6		26.3				40.0				51.7						67.2									86.0
BJ141		17.6		26.3				40.0				51.7						67.2									
RG402 (.141 S/R)		16.5		24.8				37.9				49.0						64.0									82.2
402TP		16.5		24.8				37.9				49.0						64.0									82.2
AL141TP		16.5		24.8				37.9				49.0						64.0									82.2
RG405 (.086 S/R)		27.9		40.8				60.5				76.7						97.9									123.0
405TP		27.9		40.8				60.5				76.7						97.9									123.0
AL085TP		29.5		43.1				63.8				80.8						102.9									128.9
Mini-Flex 105		27.7		34.5				45.7				67.5						95.1									
BJ085		29.2		42.8				63.3				80.1						102.1									
BJ047		47.8		68.9				100.3				125.5						157.6									
Mini-Flex 065		51.1		72.7				103.6				127.7						157.6									191.0
(.047 S/R)		47.8		68.9				100.3				125.5						157.6									194.7
Standard MIL-C-17 / RG Series																											
SF 142		18.0		26.8				40.7				52.5						68.3									
RG142		18.9		28.1				42.5																			
RG400		21.5		31.7				47.7				61.1															
142D		24.7		37.8				59.4				78.2						104.0									
SF316		37.3		54.1				79.4				99.8						126.3									
RD316		37.6		54.6				79.9				100.6															
RG316		37.6																									
316D		39.0		57.1																							
RG223		19.7		29.3				44.4				57.2															
LMR																											
LMR-400		6.0		8.8				10.8																			
LMR-400-UF		7.2		10.5				24.4																			
LMR-240		11.5		16.6				20.4																			
LMR-240-LLPL		11.5		16.5				20.0																			
LMR-240-UF		13.9		10.5				24.4																			
LMR-195		16.9		24.5				29.9																			
LMR-100A-PVC		35.2		51.8				64.1																			

To select a cable first determine the maximum frequency the cable assembly needs to operate at. Cables under that frequency are listed by lowest (dB/100 ft) attenuation first.

Cable Selection Guide

By Attenuation (dB per 100 feet)

Ka											mm																												
27	28	29	30	31	32	33	34	35	36	37	38	39	40	41	42	43	44	45	46	47	48	49	50	51	52	53	54	55	56	57	58	59	60						
			67.5					73.7																															
			115.5					125.5					134.8					143.7																					
			94.9					105.6																															
			90.7					101.1																															
			90.7					101.1																															
			90.7					101.1																															
			134.6					148.5					161.8				174.7						187.1						199.4										
			134.6					148.5					161.8				174.7					187.1						199.4											
			141.0					155.4					169.2				182.6					195.4																	
													154.8																										
			205.9					223.3					239.7																										
			211.6					231.7					250.8				269.1						286.7																

Cable Selection Guide

By Power (Watts)

BAND Frequency (GHz)	L		S		C				X				Ku				K											
	1	2	3	4	5	6	7	8	9	10	11	12	13	14	15	16	17	18	19	20	21	22	23	24	25	26		
Semi-Rigid, Low-Loss																												
AL250LLTP		2567		2100				1167				640						460								400		
AL141LLSP		399		268				165				131						105										
AL085LLSP		119		80				58				45						30									22	
Semi-Rigid, Conformable (BJ), Flexible (Mini-Flex)																												
RG401 (.250 S/R)		1250		950				500				290						200										
250TP		1250		950				500				290						200										
Mini-Flex 165		550		450				250				130						100										
K-Jumper		401		184				120				96						74										
BJ141		401		184				120				96						74										
RG402 (.141 S/R)		353		304				159				96						75										
402TP		353		304				159				96						75										
AL141TP		353		304				159				96						75										
RG405 (.086 S/R)		116		88				47				29						23										
405TP		116		88				47				29						23										
AL085TP		116		88				47				29						23										
Mini-Flex 105		110		90				50				26						20										
BJ085		79		54				38				32						21										
BJ047		79		54				38				32						21										
Mini-Flex 065		43		39				30				22						9										
(.047 S/R)		29		22				12				8						7										
Standard MIL-C-17 / RG Series																												
SF 142		340		239				150				114						85										
RG142		330		229				140																				
RG400		290		190				130				100		93														
142D		150		105				70				58						45										
SF316		140		90				60				50						30										
RD316		123																										
RG316		123		93																								
316D		65		47			38																					
RG223		60		40			25					20		19														
LMR																												
LMR-400		370		250			200																					
LMR-400-UF		310		210			170																					
LMR-240		170		120			90																					
LMR-240-LLPL		140		100			80																					
LMR-240-UF		140		100			80																					
LMR-195		90		60			50																					
LMR-100A-PVC		30		20			10																					

Note: CW Power in watts at sea level and 25°C
 To select a cable first determine the maximum frequency the cable assembly needs to operate at.
 Cables under that frequency are listed by Maximum Power Handling (Watts) first.

Consult Sales Department for Ratings

Cable Selection Guide

Cables & Connectors

Connector Frequency (Max)				GHz	Cable Freq. (Max)			Power				Subminiature			
Cable Family				Cable Code	Specification		Type N	SC	7/16 DIN	SSMA	SMA	SMB	SMC		
Semi-Rigid, Low Loss															
AL085LLSP	AL085LLSP	FRFL	62	18					36	18	10	10			
AL141LLSP	AL141LLSP	FRFL	35	18					18	10					
AL250LLTP	AL250LLTP	FRFL	20	18					18						
Semi-Rigid, Conformable (BJ), Flexible (Mini-Flex)															
(.047 S/R)	047	FRFL	50							18					
047TP	047TP	M17/151-00002	50						18						
BJ047	BJ047	FRFL	18						18						
Mini-Flex 065	065	FRFL	55						18						
405TP	405TP	FRFL	60	18					36	26	10	10			
RG405 (.086 S/R)	RG405	M17/133-RG405	60	18					36	26	10	10			
AL085TP	AL085	M17/133-00013	60	18					36	26	10	10			
BJ085	BJ086	FRFL	18	18					18	18	10	10			
Mini-Flex 105	105	FRFL	60	18					36	26	10	10			
K-Jumper	JUMP	FRFL	35												
RG402 (.141S/R)	RG402	M17/130-RG402	35	18					18	10					
402TP	402TP	M17/130-00005	35	18					18	10					
AL141TP	AL141	M17/130-00009	35	18					18	10					
BJ141	BJ142	FRFL	18	18					18	10					
Mini-Flex 165	165	FRFL	35	18					18	10					
RG401 (.250 S/R)	RG401	M17/129-RG410	18	18					18						
250TP	250TP	M17/129-00001	18	18					18						
Standard MIL-C-17 / RG Series															
SF142	SF142	FRFL	18	18	11	7			18						
142D	142D	FRFL	18	18	11	7			18						
SF316	SF316	FRFL	18	18					18	18	10	10			
RG142	RG142	M17/60-RG142	8	8	8	7			8						
RG223	RG223	M17/84-RG223	12	12	11	7			12						
RG400	RG400	M17/128-RG400	12	12	11	7			12						
RD316	RD316	M17/152-00001	12	12					12	12	10	10			
316D	316D	FRFL	5	5					5	5	5	5			
RG316	RG316	M17/113-RG316	3	3					3	3	3	3			
LMR															
LMR-100A-PVC	L100	Times	5.8	5.8					5.8	5.8	5.8	5.8			
LMR-240	L240	Times	5.8	5.8					5.8	5.8					
LMR-240-DB	L240DB	Times	5.8	5.8					5.8						
LMR-240-UF	L240UF	Times	5.8	5.8					5.8						
LMR-240-LLPL	L240LLPL	Times	5.8	5.8					5.8						
LMR-400	L400	Times	5.8	5.8					5.8						
LMR-400-DB	L400DB	Times	5.8	5.8		5.8			5.8						
LMR-400-UF	L400UF	Times	5.8	5.8		5.8			5.8						
LMR-400-LLPL	L400LLPL	Times	5.8	5.8		5.8			5.8						

	<u>Precision</u>			<u>Miniature</u>				<u>Microminiature</u>				
	1.85 mm	2.4 mm	2.92 mm	PKZ	OSP (BMA)	TNC	BNC	GPPO (SSMP)	GPO (SMP)	OSSP (BMMA)	MCX	MMCX
	65	50	40	26	22	18	4	65	40	28	6	6
Cable Family												
Semi-Rigid, Low Loss												
AL085LLSP	62	50	40	26	22	18	4	62	40	28	6	6
AL141LLSP			35	26	22	18	4				6	
AL250LLTP						18						
Semi-Rigid, Conformable, Flexible												
(.047 S/R)								50	40			
047TP								50	40			
BJ047								18	18			
Mini-Flex 065												
405TP		50	40	26	22	18	4	60	40	28	6	6
RG405 (.086 S/R)		50	40	26	22	18	4	60	40	28	6	6
AL085TP		50	40	26	22	18	4	60	40	28	6	6
BJ085		18	18	18	18	18	4	18	18	18	6	6
Mini-Flex 105		50	40	26	22	18	4					
K-Jumper			35									
RG402 (.141S/R)				26	22	18	4				6	
402TP				26	22	18	4				6	
AL141TP				26	22	18	4				6	
BJ141				18	18	18	4				6	
Mini-Flex 165				26	22	18	4				6	
RG401 (.250 S/R)						18						
250TP						18						
Standard MIL-C-17 / RG Series												
SF142				18	18	18	4					
142D				18	18	18	4					
SF316				18	18	18	4	18	18	6	6	
RG142				8	8	8	4					
RG223				12	12	12	4					
RG400				12	12	12	4					
RD316				12	12	12	4			12	6	6
316D				5	5	5	4			5	5	5
RG316				3	3	3	4	3	3	3	3	3
LMR												
LMR-100A-PVC				5.8	5.8	5.8	4		5.8	5.8	5.8	5.8
LMR-240						5.8	4					
LMR-240-DB						5.8	4					
LMR-240-UF						5.8	4					
LMR-240-LLPL						5.8	4					
LMR-400						5.8	4					
LMR-400-DB						5.8	4					
LMR-400-UF						5.8	4					
LMR-400-LLPL						5.8	4					

Semi-Rigid, Conformable & Flexible Family of cables use common connectors originally designed for semi-rigid type cable. The semi-rigid cables are available with a copper or aluminum jacket and available with a selection of different platings and in 4 different diameters (.047", .085", .141" & .250"). The Conformable®, or hand formable, (BJ - Braided Jacket), has a tin filled braid with a metal foil underlay for shielding and mechanical integrity. The flexible version, our Mini-Flex, has an FEP jacket, round braid and inner spiral shields and is available in 3 diameters, .065" .105" & .165". All 3 types, (Semi-Rigid, Conformable & Mini-Flex) are manufactured using the same type of dielectric core and have virtually the same electrical performance. Your cable choice should be primarily based upon your specific application and any mechanical considerations.

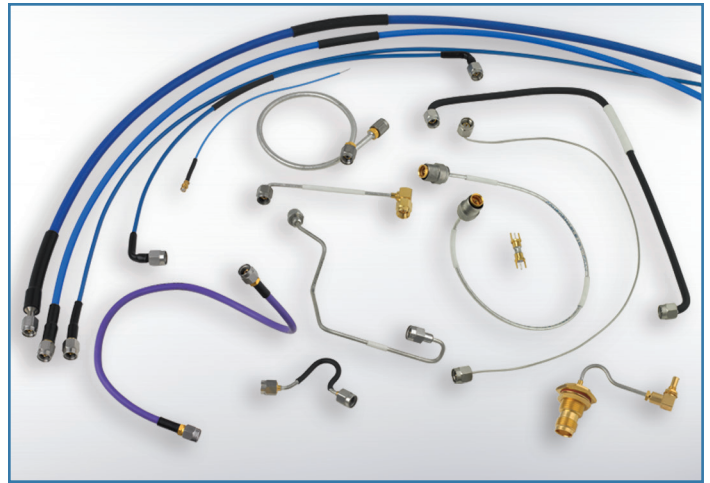

Features:

- 3 Basic Styles - Formed to Configuration, Hand-Formable and Flexible
- Pre-formed Right Angles Available on Some Cable Types
- High Frequency - Up to 65 GHz for Semi-Rigid and Mini-Flex, 18 GHz for BJ Hand-formable
- High Isolation: Up to >100 dB
- Direct Solder Connectors - Stainless Steel Construction is Standard
- Phase Matched Pairs and Sets Available
- Range of Protective Covering Options
- Many Cost-Effective Solutions

Typical Applications:

- In Box Interconnects
- Component Interconnects
- Test cables

Semi-Rigid Jacket Options:

- Copper - Bare, Tin & Silver plated
- Aluminum - Tin, Silver & Tin/Lead plated

Semi-Rigid, Conformable® & Flexible Family

.047" Specifications

General Specifications	Semi-Rigid		Conformable	Mini Flex
	047	047TP	BJ047	065
MIL Number	M17/151-00001	M17/151-00002	N/A	N/A
Diameter	0.047	0.047	0.047	0.068
Frequency, Max (GHz)	65	65	18	50
Loss @ 5 GHz (dB/100ft)	78	78	89	77

Electrical Specifications	047	047TP	BJ047	065
Impedance, Nominal (Ω)	50	50	50	50
Velocity of Propagation (%)	69.5	69.5	69.5	76
Shielding Effectiveness, 18 GHz (dB/ft)	>100	>100	>90	>85
Capacitance (pF/ft)	29.5	29.5	29.5	27
Delay (ns/ft)	1.46	1.46	1.46	1.34

Mechanical Specifications	047	047TP	BJ047	065
Weight (lbs/100ft)	0.45	0.45	0.38	0.95
Temperature Range (°C)	-55 to +125	-55 to +125	-55 to +170	-65 to +165
Minimum Bend Radius (inches)	0.15	0.15	0.12	0.3

Construction Data	047	047TP	BJ047	065
Inner Conductor	Solid SC	Solid SC	Solid SCCS	Solid SCCS
Dielectric	Solid PTFE	Solid PTFE	Solid TFE	Low Density ePTFE
First Outer Shield	N/A	N/A	N/A	Flat Braid SPC
Second Outer Shield	N/A	N/A	N/A	Round Braid SPC
Jacket	Bare Copper	Bare Copper	Unjacketed	ETFE

Semi-Rigid, Conformable® & Flexible Family

.085" Specifications

General Specifications	Semi-Rigid			Conformable	Mini Flex
	RG405	405TP	AL085	BJ085	105
MIL Number	M17/133-RG405	M17/133-00001	M17/133-00013	N/A	N/A
Diameter	0.086	0.086	0.086	0.085	0.105
Frequency, Max (GHz)	60	60	60	18	40
Loss @ 5 GHz (dB/100ft)	46	46	47	49	48

Electrical Specifications	RG405	405TP	AL085	BJ085	105
Impedance, Nominal (Ω)	50	50	50	50	50
Velocity of Propagation (%)	69.5	69.5	69.5	69.5	69.5
Shielding Effectiveness, 18 GHz (dB/ft)	>100	>100	>100	>90	>90
Capacitance (pF/ft)	29.4	29.4	29.4	29.4	29.4
Delay (ns/ft)	1.46	1.46	1.46	1.46	1.46

Mechanical Specifications	RG405	405TP	AL085	BJ085	105
Weight (lbs/100ft)	1.53	1.53	0.73	1.19	1.3
Temperature Range ($^{\circ}\text{C}$)	-55 to +125	-55 to +125	-55 to +125	-55 to +160	-55 to +170
Minimum Bend Radius (inches)	0.17	0.17	0.25	0.12	0.25

Construction Data	RG405	405TP	AL085	BJ085	105
Inner Conductor	Solid SCCS	Solid SCCS	Solid SCCS	Solid SCCS	Solid SCCS
Dielectric	Solid PTFE	Solid PTFE	Solid PTFE	Solid PTFE	Solid PTFE
First Outer Shield	N/A	N/A	N/A	N/A	Metal Tape SPC
Second Outer Shield	N/A	N/A	N/A	N/A	Braid SPC
Jacket	Bare Copper	Tin Plated Copper	Tin Plated Aluminum	Tin-Filled Composite	FEP

Semi-Rigid, Conformable® & Flexible Family

.141" Specifications

	Semi-Rigid		Conformable	Mini Flex	
General Specifications	RG402	AL141	BJ141	165	K-Jumper
MIL Number	M17/130-RG402	M17/130-00005	N/A	N/A	N/A
Diameter	0.141	0.141	0.141	0.162	0.165
Frequency, Max (GHz)	35	35	18	35	35
Loss @ 5 GHz (dB/100ft)	29	30	31	31	31

Electrical Specifications	RG402	AL141	BJ141	165	K-Jumper
Impedance, Nominal (Ω)	50	50	50	50	50
Velocity of Propagation (%)	69.5	69.5	69.5	69.5	69.5
Shielding Effectiveness, 18 GHz (dB/ft)	>100	>100	>90	>90	>90
Capacitance (pF/ft)	29.5	29.9	29.5	29.5	29.5
Delay (ns/ft)	1.46	1.45	1.46	1.45	1.46

Mechanical Specifications	RG402	AL141	BJ141	165	K-Jumper
Weight (lbs/100ft)	3.44	1.88	2.00	2.91	2.00
Temperature Range ($^{\circ}$ C)	-55 to +125	-50 to +125	-55 to +160	-55 to +125	-55 to +125
Minimum Bend Radius (inches)	0.32	0.32	0.25	0.50	0.25

Construction Data	RG402	AL141	BJ141	165	K-Jumper
Inner Conductor	Solid SCCS	Solid SCCS	Solid SCCS	Solid SCCS	Solid SCCS
Dielectric	Solid PTFE	Solid PTFE	Solid PTFE	Solid PTFE	Solid PTFE
First Outer Shield	N/A	N/A	N/A	Metal Tape SPC	Tin-Filled Composite
Second Outer Shield	N/A	N/A	N/A	Braid SPC	N/A
Jacket	Tin Plated Copper	Tin Plated Aluminum	Tin-Filled Composite	FEP	Polyolefin

General Specifications	Semi-Rigid	
	RG401	250TP
MIL Number	M17/129-RG401	M17/129-00001
Diameter	0.25	0.25
Frequency, Max (GHz)	18	18
Loss @ 5 GHz (dB/100ft)	19	19

Electrical Specifications	RG401	250TP
Impedance, Nominal (Ω)	50	50
Velocity of Propagation (%)	69.5	69.5
Shielding Effectiveness, 18 GHz (dB/ft)	>100	>100
Capacitance (pF/ft)	29.4	29.4
Delay (ns/ft)	1.46	1.46

Mechanical Specifications	RG401	250TP
Weight (lbs/100ft)	10.5	10.5
Temperature Range (°C)	-55 to +125	-55 to +125
Minimum Bend Radius (inches)	0.5	0.5

Construction Data	RG401	250TP
Inner Conductor	Solid SCCS	Solid SCCS
Dielectric	Solid PTFE	Solid PTFE
First Outer Shield	N/A	N/A
Second Outer Shield	N/A	N/A
Jacket	Bare Copper	Tin Plated Copper

Semi-Rigid, Conformable® & Flexible Family

Performance

Attenuation (dB/100ft)						
GHz	047	085	141	250		
1	33.3	19.2	11.2	6.8		
5	77.7	46.2	28.3	18.6		
10	113.4	68.9	43.6	29.8		
18	145.0	82.5	64.0	45.5		
20	169.0	104.5	68.7			
26	190.0	122.9	82.2			
30	211.6	134.6	90.7			
35	231.7	148.5	101.1			
40	250.8	161.8				
45	269.1	174.7				
50	286.7	187.2				
55	303.8	199.4				
60	320.4	211.4				
65	336.5					

Max Cable Loss at +25° C & Sea Level

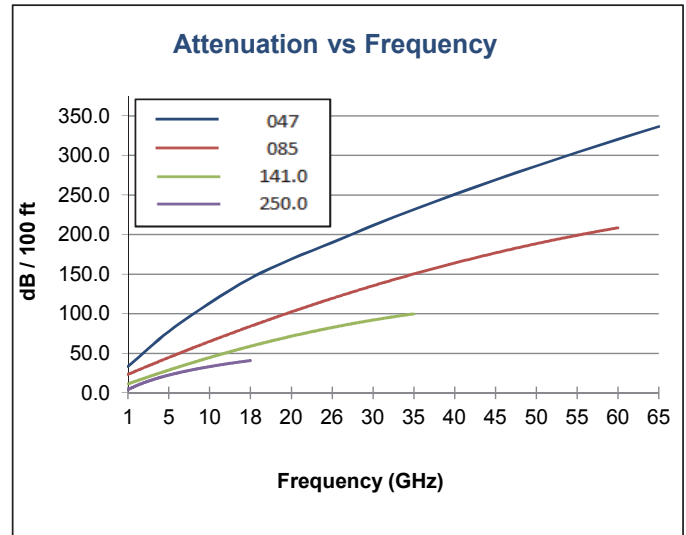

Average Power Rating (Watts)						
GHz	047	085	141	250		
1	32	130	450	1400		
5	13	53	280	875		
10	9	33	110	350		
18	8	31	93	276		
20	7	30	76			

Power handling is specified for ambient conditions at sea level and +25° C

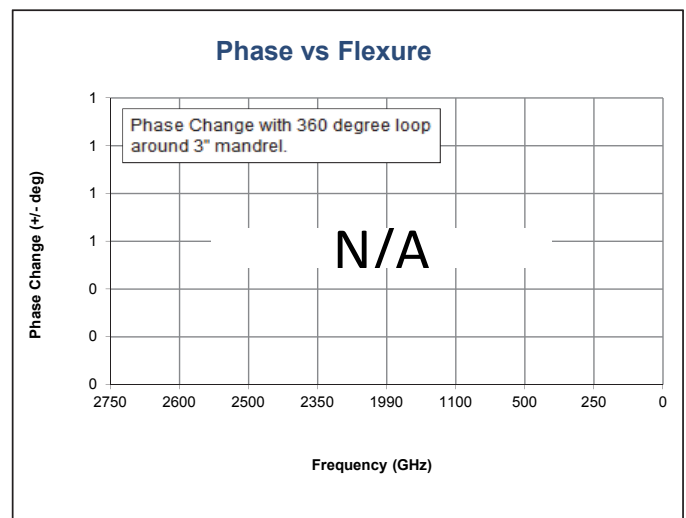
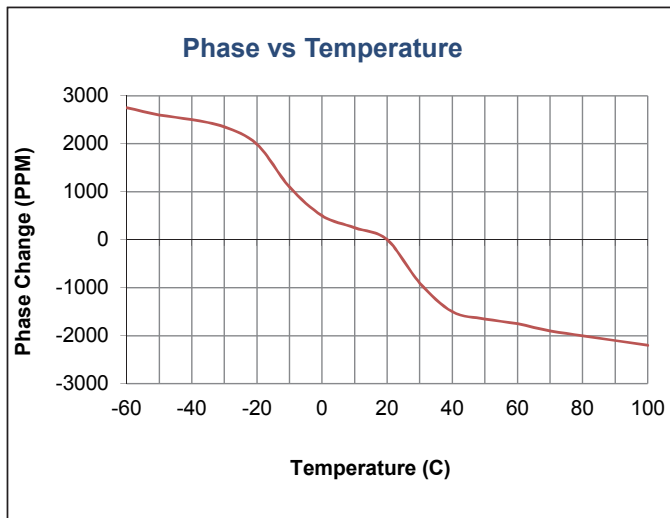
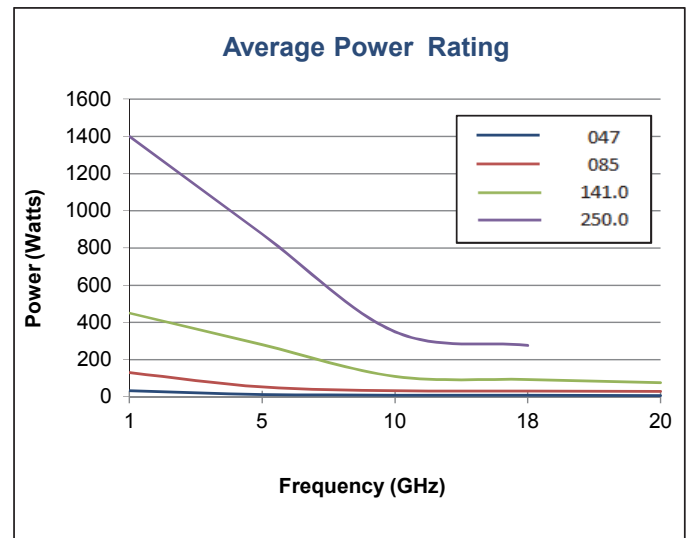

Semi-Rigid, Conformable® & Flexible Family

Connector Selection & Options

Standard					Frequency Max GHz*	Series 047	Series 085	Series 141	Series 250
2.4 mm	Plug	(Male)	Straight	50			MMS		
2.4 mm	Plug	(Male)	R/A	50			MMSR ²		
2.4 mm	Jack	(Female)	Straight	50			MFS		
2.4 mm	Bulkhead	(Female)	Straight	50			MFBS		
2.9 mm	Plug	(Male)	Straight	40			KMS	KMS	
2.9 mm	Plug	(Male)	R/A	40			KMSR ²	KMSR ²	
2.9 mm	Jack	(Female)	Straight	40			KFS		
2.9 mm	Bulkhead	(Female)	Straight	40			KFBS		
GPPO	Jack	(Female)	Straight	50	GPPOFS	GPPOFS			
GPO	Jack	(Female)	Straight	40	SMPFS	SMPFS			
GPO	Jack	(Female)	R/A	40	SMPFR	SMPFR			
SMA	Plug	(Male)	Straight	18	SMS	SMS	SMS	SMS	
SMA	Plug	(Male)	R/A	18	SMSR ²	SMSR ²	SMSR ²	SMSR ²	
SMA	Plug	(Male)	R/A	18		SMR	SMR	SMR	
SMA	Jack	(Female)	Straight	18	SFS	SFS	SFS	SFS	
SMA	Bulkhead	(Female)	Straight	18		SFBS	SFBS	SFBS	
OSSP	Bulkhead	(Female)	Straight	18		OSSPMBS			
OSP	Bulkhead	(Male)	Straight	18		OSPMBS	OSPMBS	OSPMBS	
Type N	Plug	(Male)	Straight	18		NMS	NMS	NMS	NMS
Type N	Plug	(Male)	R/A	18			NMSR ²	NMSR ²	
Type N	Bulkhead	(Female)	Straight	18		NFBS	NFBS	NFBS	NFBS
TNC	Plug	(Male)	Straight	18		TMS	TMS	TMS	TMS
TNC	Plug	(Male)	R/A	18			TMSR ²	TMSR ²	TMSR ²
TNC	Jack	(Female)	Straight	18			TFS	TFS	
TNC	Plug	(Male)	R/A	18			TMR	TMR	
TNC	Bulkhead	(Female)	Straight	18			TFBS	TFBS	
MCX	Plug	(Male)	R/A	6			MCXMR	MCXMR	
MCX	Plug	(Male)	Straight	6			MCXMS	MCXMS	
MMCX	Plug	(Male)	Straight	6			MMCXMS		
MMCX	Plug	(Male)	R/A	6			MMCXMR		
SMB	Bulkhead	(Female)	Straight	4			SMBFS		
BNC	Plug	(Male)	Straight	4			BMS	BMS	
BNC	Bulkhead	(Female)	Straight	4			BFBS	BFBS	

Gender of the connector is determined by center pin.

² = Straight Connector with pre-bend cable to form right angle.

Consult sales department for other connectors and options not shown.

* Max Frequency of connectors may be limited by the cable selected.

* Phase Matched sets available: +/- 2.8 picoseconds

* Weatherization Protection Available (Polyolefin): Option W

Semi-Rigid, Conformable® & Flexible Family

Options & Ordering Information

Cable Options

W - Weatherized-Polyolefin



D - Dust Caps



Part Numbering Code

Ordering Information

S M S - B J 0 8 5 - - 1 8 . 0 - S M R ± 2 . 8 P S
CONNECTOR #1 CABLE TYPE OPTION LENGTH (IN.) CONNECTOR #2 OPTION
Blank = None Example:
W = Weatherized 18.0 = 18 inches
P = Phase Matched



Description:

The .047" diameter series offers one of the smallest diameter cables available for a range of subminiature connectors. This group, consisting of Semi-Rigid, BJ047 and Mini-Flex 065 is used where space is at a premium and higher losses can be tolerated.

Features/Benefits:

- Mode Free Operation to 65 GHz
- Superior Shielding Effectiveness
- Stainless Steel Connectors Available
- Maintains Tightly Controlled Mechanical Configurations
 - High Vibration Resistance
 - Light Weight

Applications:

- Instrumentation
- Jumpers
- Military

Standard Connectors:

Connector Code	Series	Gender	Type	Loss per GHz	Frequency Max GHz
SMS	SMA	Male	Straight	0.01	18
SFS	SMA	Female	Straight	0.015	12
SMPFS	SMP	Female	Straight	0.02	40
SMPFR	SMP	Female	R/A	0.03	40
SSMS	SSMA	Male	Straight	0.01	34
SSMR	SSMA	Male	R/A	0.02	34

Standard Options:

Option Code	Option Description
W	Weatherized
N	Neoprene
±2.8PS	Phase Matched (+/-2.8 picoseconds)

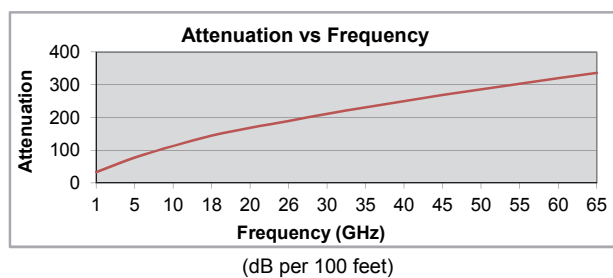

GHz	1	5	10	18	26	30	35	40	45	50	55	60	65
Atten	33	78	113	145	190	212	232	251	269	287	304	320	336

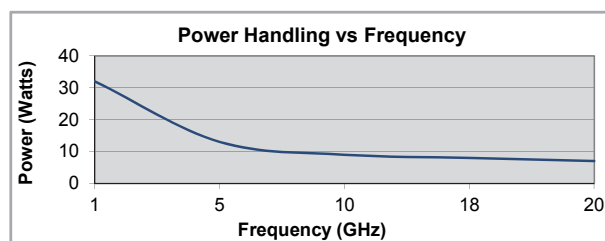

*CW Power in watts at sea level and 23°C

GHz	1	6	10	18	20
Pow.	32	13	9	8	7

.085 Series

Semi-Rigid BJ085 Mini-Flex 105

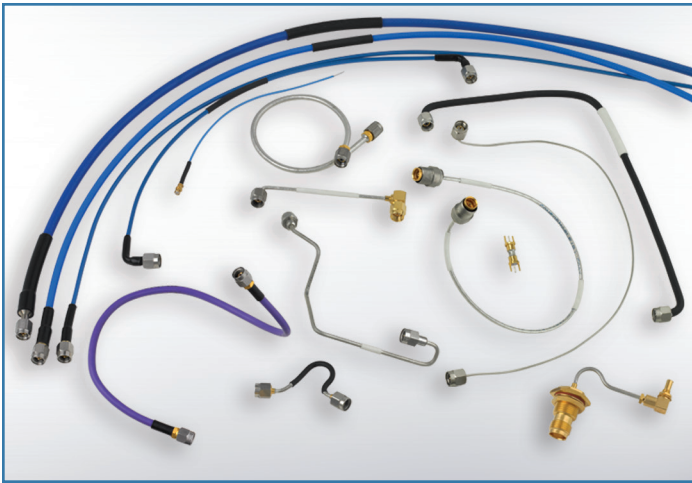

Standard Connectors:

Connector Code	Series	Gender	Type	Loss per GHz	Frequency Max GHz
SMS	SMA	Male	Straight	0.01	18
SMR	SMA	Male	R/A	0.02	18
SFBS	SMA	Female	Straight	0.01	18
SFS	SMA	Female	Straight	0.01	18
NMS	Type N	Male	Straight	0.011	18
NFBS	Type N	Female	Straight	0.01	18
TMS	TNC	Male	Straight	0.01	18
TMR	TNC	Male	R/A	0.02	18
TFBS	TNC	Female	Straight	0.015	18
SMPFS	SMP	Female	Straight	0.015	40
SMPFR	SMP	Female	R/A	0.02	40
SMBFR	SMB	Female	R/A	0.02	40
SMBFS	SMB	Female	Straight	0.015	40
MCXMS	MCX	Male	Straight	0.01	6
MCXMR	MCX	Male	R/A	0.02	6
MMCXMS	MMCX	Male	Straight	0.01	6
MMCXMR	MMCX	Male	Straight	0.01	6
BMS	BNC	Male	Straight	0.01	4
BMR	BNC	Male	R/A	0.02	4
BFBS	BNC	Female	Straight	0.015	4
OSPMBS	OSP	Male	Straight	0.01	22
OSSPMBS	OSSP	Male	Straight	0.01	28

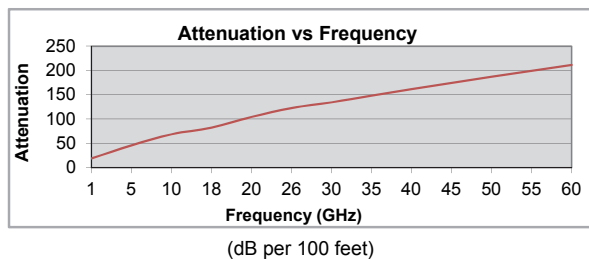

Description:

The popular .085" diameter series offers a wide range of connector interfaces from GPPO to TNC. Semi-Rigid is typically used for high reliability applications, formable BJ085 for low cost interconnects and the Mini-Flex 105 for high frequency interconnects and test assemblies. Both the Semi-Rigid and Mini-Flex 105 are mode free to 60 GHz. The cost-effective BJ085 cable is typically used in lower frequency applications of 18 GHz or less.

Features/Benefits:

- Mode Free Operation to 60 GHz
- Superior Shielding Effectiveness
- Stainless Steel Connectors Available
- Maintains Tightly Controlled Mechanical Configurations
 - High Vibration Resistance
 - Light Weight

Applications:

- Instrumentation
- Jumpers
- Satellite Component Interconnects

Standard Options:

Option Code	Option Description
W	Weatherized
N	Neoprene
±2.8PS	Phase Matched (+/-2.8 picoseconds)

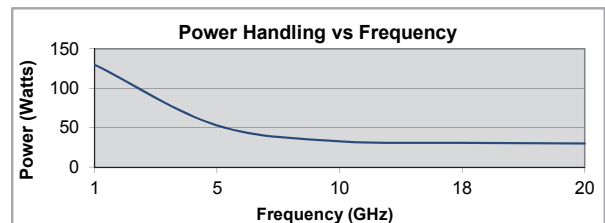

*CW Power in watts at sea level and 23 °C

GHz	1	5	10	18	20	26	30	35	40	45	50	55	60
Atten	19	46	69	83	105	123	135	149	162	175	187	199	211

GHz	1	5	10	18	20
Pow.	130	53	33	31	30

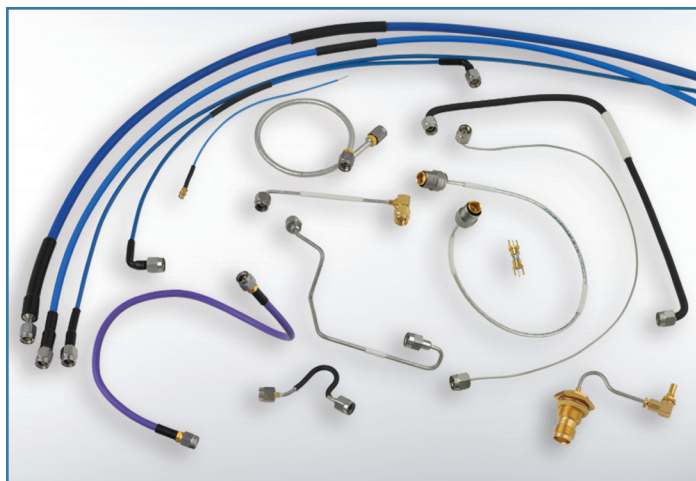

Description:

The widely used .141" series offers a broad range of connectors from OSP to Type N. The Semi-Rigid, known for its excellent shielding, is popular in military applications, the hand-formable BJ141 for low cost interconnects and the Mini-Flex 165 can all use the same connectors. Semi-Rigid, K-Jumper and Mini-Flex 165 are all mode free to 36 GHz while the BJ141 is recommended for applications up to 18 GHz.

Features/Benefits:

- Mode Free Operation to 35 GHz
- Superior Shielding Effectiveness
- Wide Connector Selection
 - Maintains Tightly Controlled Mechanical Configurations
 - High Vibration Resistance
 - Light Weight

Applications:

- Test Cables
- Jumpers
- Instrumentation
- High Frequency Interconnects

Standard Connectors:

Connector Code	Series	Gender	Type	Loss per GHz	Frequency Max GHz
KMS	2.9mm	Male	Straight	0.01	35
SMS	SMA	Male	Straight	0.01	18
SMR	SMA	Male	R/A	0.02	18
SFBS	SMA	Female	Straight	0.01	18
SFS	SMA	Female	Straight	0.01	18
NMS	Type N	Male	Straight	0.01	18
NFBS	Type N	Female	Straight	0.01	18
TMS	TNC	Male	Straight	0.01	18
TMR	TNC	Male	R/A	0.02	18
TFBS	TNC	Female	Straight	0.015	18
TFS	TNC	Female	Straight	0.015	18
MCXMS	MCX	Male	Straight	0.01	6
MCXMR	MCX	Male	R/A	0.02	6
BMS	BNC	Male	Straight	0.01	4
BFBS	BNC	Female	Straight	0.01	4
OSPMS	OSP	Male	Straight	0.01	22

Standard Options:

Option Code	Option Description
W	Weatherized
N	Neoprene
±2.8PS	Phase Matched (+/-2.8 picoseconds)

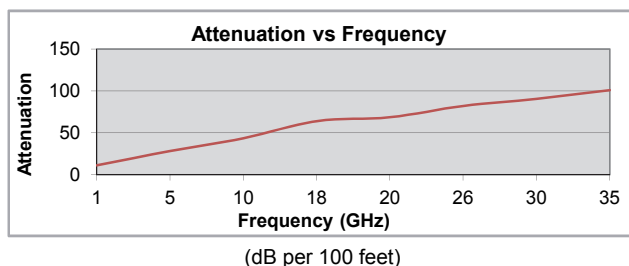

GHz	1	5	10	18	20	26	30	35
Atten	11	28	44	64	69	82	91	101

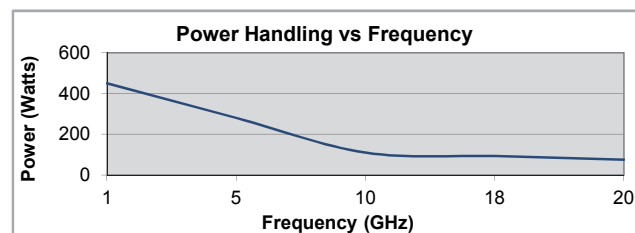

*CW Power in watts at sea level and 23°C

GHz	1	5	10	18	20
Pow.	450	280	110	93	76

.250 Series

Semi-Rigid RG401 401TP

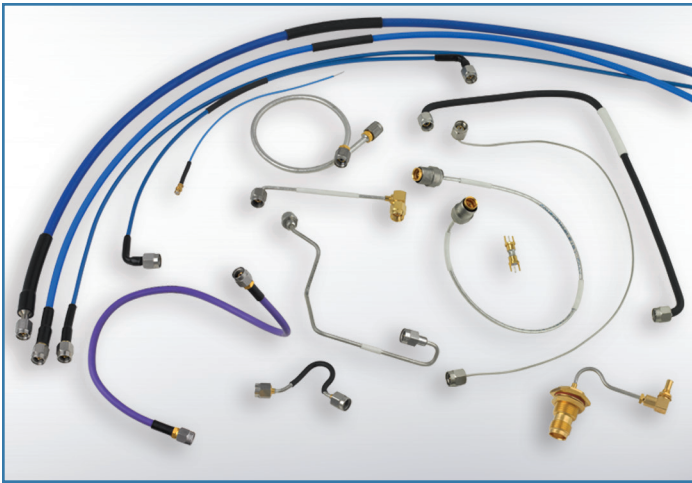

Description:

Our .250" diameter Semi-Rigid cable is used wherever power and lower loss are required with the reliability of a high shielded cable. Larger connectors such as Type N and TNC with extended performance to 18 GHz offer excellent power handling performance. These cables are available in both copper and aluminum jackets and tin and silver plated.

Features/Benefits:

- Mode Free Operation to 18 GHz
- Superior Shielding Effectiveness
- Stainless Steel Connectors Available
- Maintains Tightly Controlled Mechanical Configurations
 - High Vibration Resistance
 - Light Weight
 - High Power / Low Insertion Loss

Applications:

- RF Power Generators
- Jumpers
- Military
- Satcom

Standard Connectors:

Connector Code	Series	Gender	Type	Loss per GHz	Frequency Max GHz
SMS	SMA	Male	Straight	0.01	18
SFBS	SMA	Female	Straight	0.01	18
SFS	SMA	Female	Straight	0.01	18
NMS	Type N	Male	Straight	0.011	18
NFBS	Type N	Female	Straight	0.01	18
TMS	TNC	Male	Straight	0.01	18
TFBS	TNC	Female	Straight	0.015	18

Standard Options:

Option Code	Option Description
D	Dust Caps
N	Neoprene
±2.8PS	Phase Matched (+/-2.8 picoseconds)

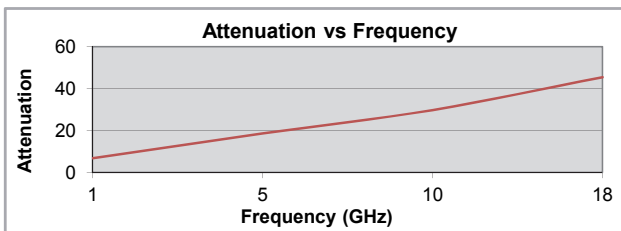

(dB per 100 feet)

GHz	1	5	10	18
Atten	7	19	30	46

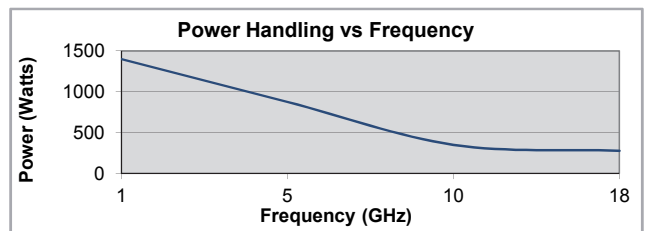

*CW Power in watts at sea level and 23°C

GHz	1	5	10	18
Pow.	1400	875	350	276

Our **Low Loss Semi-Rigid Family** of cables are used in applications requiring superior phase stability and lower insertion loss than is possible with standard solid dielectric semi-rigid types. The aluminum jacketed cable is most popular for space applications since weight, loss and stability over temperature are all major concerns in this environment. Our special low density dielectric offers dramatically improved mechanical durability and phase stability over the solid dielectric types. Custom connectors must be used due to the special core diameters. Please contact our technical sales staff for custom configurations and special screening or testing requirements you may require.

Features:

- Superior Phase Stability
- Special Low Density Dielectric
- Space-Qualified
- Frequencies up to 55 GHz
- 100 dB Minimum Isolation
- Stainless Steel, Direct Solder Connectors are Standard
- Phase Matching Available

Typical Applications:

- Satellite Component Interconnects
- High Frequency Jumpers

Semi-Rigid Jacket Options:

- Aluminum - Tin or Silver
- Copper - Bare or Tin plated

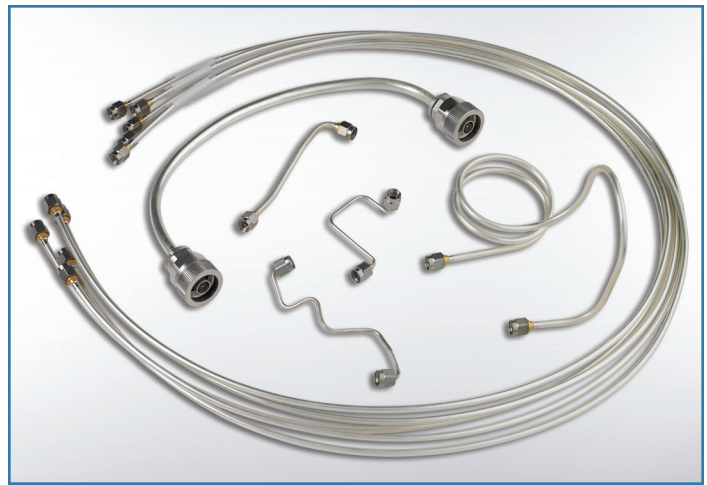

Low Loss .085		
Part Number	Jacket	Finish
AL085LLTP	Aluminum	Tin
AL085LLSP	Aluminum	Silver
LL085	Copper	None
LL085TP	Copper	Tin

Low Loss 0141		
Part Number	Jacket	Finish
AL141LLTP	Aluminum	Tin
AL141LLSP	Aluminum	Silver
LL141	Copper	None
LL141TP	Copper	Tin

Low Loss .250		
Part Number	Jacket	Finish
AL250LLTP	Aluminum	Tin
AL250LLSP	Aluminum	Silver
LL250	Copper	None
LL250TP	Copper	Tin

Semi-Rigid Low Loss Family

Specifications

General Specifications	AL085LLSP	085LL	AL141LLSP	141LLTP	AL205LLTP	250LLTP
MIL Number	N/A	N/A	N/A	N/A	N/A	N/A
Diameter	0.085	0.085	0.141	0.141	0.250	0.250
Frequency, Max (GHz)	62	62	35	35	20	20
Loss @ 5 GHz (dB/100ft)	45	45	23	25.7	13.6	9.4

Electrical Specifications	AL085LLSP	085LL	AL141LLSP	141LLTP	AL205LLTP	250LLTP
Impedance, Nominal (Ω)	50	50	50	50	50	50
Velocity of Propagation (%)	76.5	76.5	76.5	76.5	76.5	76.5
Shielding Effectiveness, 18 GHz (dB/ft)	>100	>100	>100	>100	>100	>100
Capacitance (pF/ft)	27	27	27	27	27	27
Delay (ns/ft)	1.33	1.33	1.33	1.33	1.33	1.33

Mechanical Specifications	AL085LLSP	085LL	AL141LLSP	141LLTP	AL205LLTP	250LLTP
Weight (lbs/100ft)	0.78	1.36	1.9	3.24	6.09	9.9
Temperature Range ($^{\circ}\text{C}$)	-65 to +165	-65 to +165	-65 to +165	-65 to +165	-65 to +165	-65 to +165
Minimum Bend Radius (inches)	0.25	0.25	0.5	0.5	1.5	1

Construction Data	AL085LLSP	085LL	AL141LLSP	141LLTP	AL205LLTP	250LLTP
Inner Conductor	Solid SC	Solid SC	Solid SC	Solid SC	Solid SC	Solid SC
Dielectric	Low Loss PTFE	Low Loss PTFE	Low Loss PTFE	Low Loss PTFE	Low Loss PTFE	Low Loss PTFE
First Outer Shield	N/A	N/A	N/A	N/A	N/A	N/A
Second Outer Shield	N/A	N/A	N/A	N/A	N/A	N/A
Jacket	Aluminum Silver / Tin	Copper Bare	Aluminum Silver / Tin	Copper Bare / Tin	Aluminum / Tin	Copper Bare / Tin

Attenuation (dB/100ft)						
GHz	AL085LLSP	085LL	AL141LLSP	141LLTP	250LLTP	AL250LLTP
1	17.4	19.9	10.4	10.9	5.1	5.8
5	39.7	45.3	24.0	25.1	12.6	14.0
10	57.0	65.0	34.7	36.3	19.0	21.0
18	77.9	88.6	47.8	50.0	27.3	30.0
20	82.4	93.7	50.7	52.9		
26	94.9	107.8	58.6	61.2		
30	102.5	116.4	63.6	66.3		
35	111.5	126.5	69.4	72.3		
40	120.0	136.0				
45	128.1	145.0				
50	135.8	153.6				
55	143.1	161.9				

Max Cable Loss at +25° C & Sea Level

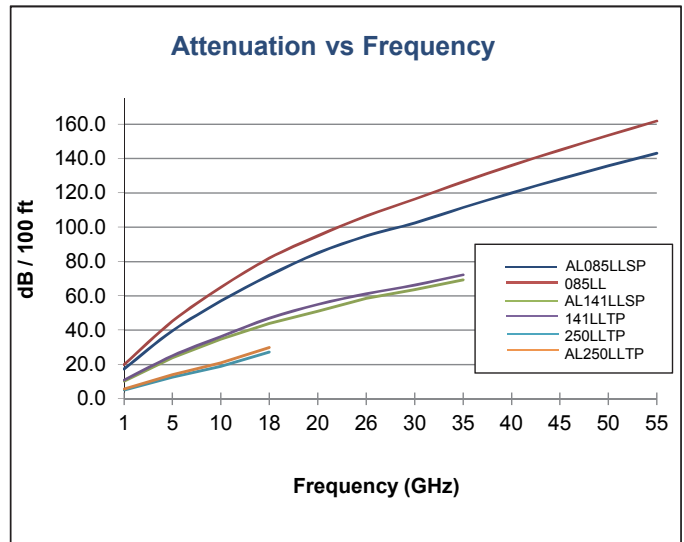

Average Power Rating (Watts)						
GHz	AL085LLSP	085LL	AL141LLSP	141LLTP	250LLTP	AL250LLTP
1	156	156	540	540	2800	2800
10	40	40	132	132	700	700
18	27	27	90	90	400	400

Power handling is specified for ambient conditions at sea level and +25° C

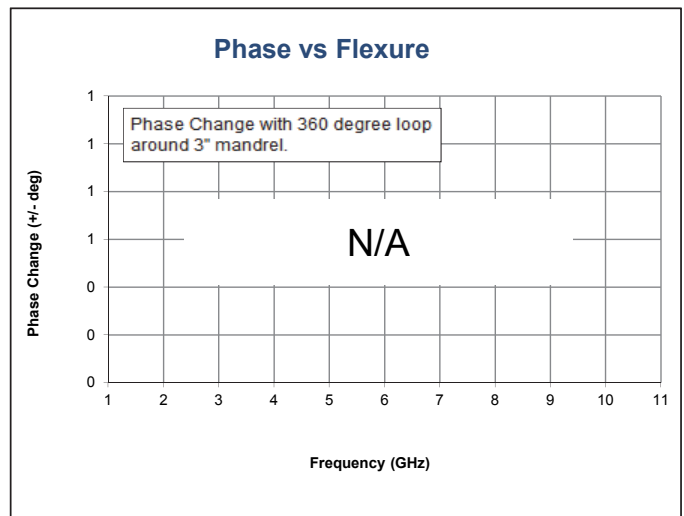
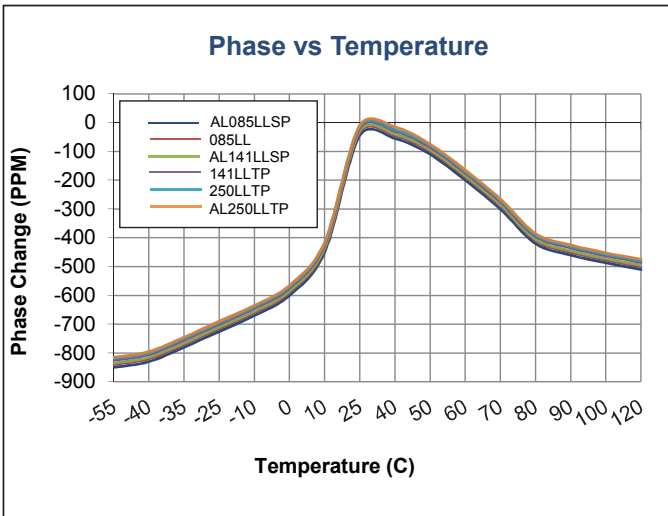
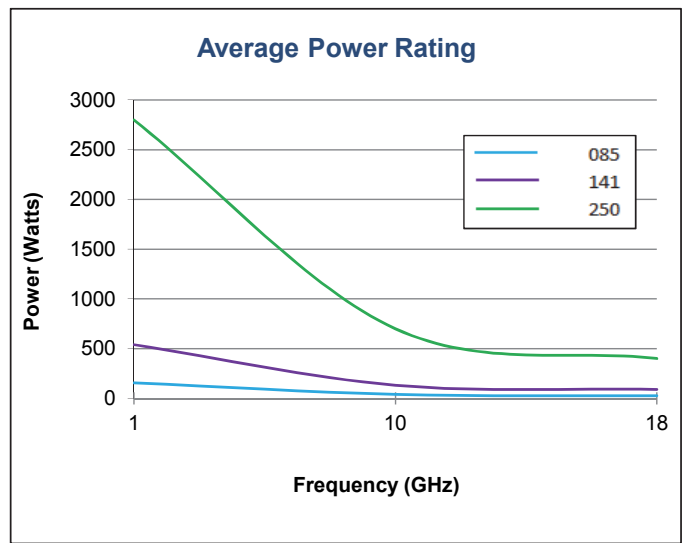

Semi-Rigid Low Loss Family

Connector Selection & Options

Low Loss					Frequency Max GHz*	Series 085	Series 141	Series 250
Connector Options				Frequency Max GHz*	Series 085	Series 141	Series 250	
2.4 mm	Plug	(Male)	Straight	50	MMS			
2.4 mm	Plug	(Male)	R/A	50	MMSR ²			
2.4 mm	Jack	(Female)	Straight	50	MFS			
2.4 mm	Bulkhead	(Female)	Straight	50	MFBS			
2.9 mm	Plug	(Male)	Straight	40	KMS	KMS		
2.9 mm	Plug	(Male)	R/A	40	KMSR ²	KMSR ²		
2.9 mm	Jack	(Female)	Straight	40	KFS			
2.9 mm	Bulkhead	(Female)	Straight	40	KFBS			
SMA	Plug	(Male)	Straight	18	SMS	SMS	SMS	
SMA	Plug	(Male)	R/A	18	SMSR ²	SMSR ²		
SMA	Jack	(Female)	Straight	18	SFS			
SMA	Bulkhead	(Female)	Straight	18	SFBS			
Type N	Plug	(Male)	Straight	18			NMS	
TNC	Plug	(Male)	Straight	18	TMS	TMS	TMS	
TNC	Plug	(Male)	R/A	18			TMR	

Gender of the connector is determined by center pin.

² = Straight Connector with pre-bend cable to form right angle.

Consult sales department for other connectors and options not shown.

* Max Frequency of connectors may be limited by the cable selected.

* Phase Matched sets available: +/- 2.8 picoseconds

* Weatherized Protection available (Polyolefin): Option W

Cable Options

W - Weatherized-Polyolefin



Part Numbering Code

Ordering Information

<u>K M S</u>	-	<u>A L 1 4 1 L L S P</u>		-	<u>1 2 . 0</u>	-	<u>K M S</u>		-	<u>± 2 . 8 P S</u>
CONNECTOR #1		CABLE TYPE	OPTION		LENGTH (IN.)		CONNECTOR #2			OPTION
			Blank = None W = Weatherized		Example: 12.0 = 12 inches					P = Phase Matched

.085 Low Loss Semi-Rigid

AL085LLSP AL085LLTP LL085 LL085TP

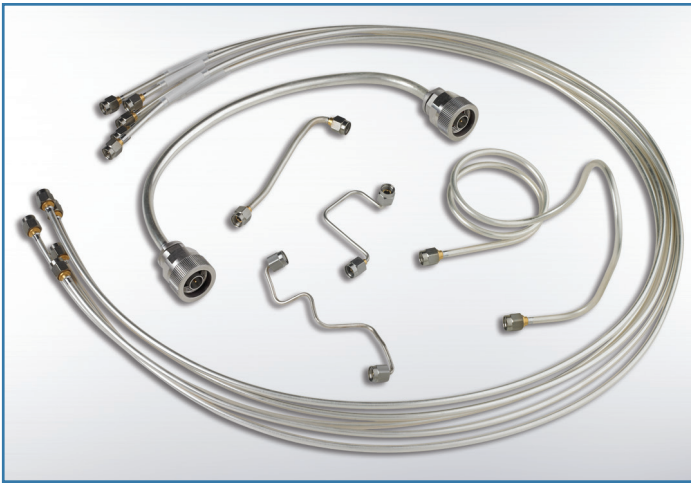

Standard Connectors:

Connector Code	Series	Gender	Type	Loss per GHz	Frequency Max GHz
MMS	2.4mm	Male	Straight	0.012	50
MFBS	2.4mm	Female	Straight	0.015	50
MFS	2.4mm	Female	Straight	0.015	50
KMS	2.9mm	Male	Straight	0.01	40
KFBS	2.9mm	Female	Straight	0.015	40
KFS	2.9mm	Female	Straight	0.015	40
SMS	SMA	Male	Straight	0.01	18
SMR	SMA	Male	R/A	0.02	18
SFBS	SMA	Female	Straight	0.01	18
SFS	SMA	Female	Straight	0.01	18
TMS	TNC	Male	Straight	0.01	18
SMPFS	SMP	Female	Straight	0.015	40
SMPFR	SMP	Female	R/A	0.02	40
OSPMBS	OSP	Male	Straight	0.01	22
OSSPMBS	OSSP	Male	Straight	0.01	28

Description:

The Low Loss, Semi-Rigid .085" diameter is very popular and has a wide range of available connectors from GPPO to SMA. This low loss cable is specially suited for high reliability applications, especially when temperature changes are a concern. Our special low-density dielectric is very stable in this environment while also offering mechanical durability during any forming of the outer jacket.

Features/Benefits:

- Mode Free Operation to 60 GHz
- Superior Shielding Effectiveness - 100dB Min.
- Stainless Steel Connectors
- Copper Jacket Bare or Tin Finish
- Aluminum Jacket Bare or Tin Finish
- High Vibration Resistance
- Aluminum 40% Lighter Weight than Copper

Applications:

- Instrumentation
- Jumpers
- Satellite Component Interconnects

Standard Options:

Option Code	Option Description
W	Weatherized
N	Neoprene
±2.8PS	Phase Matched (+/-2.8 picoseconds)

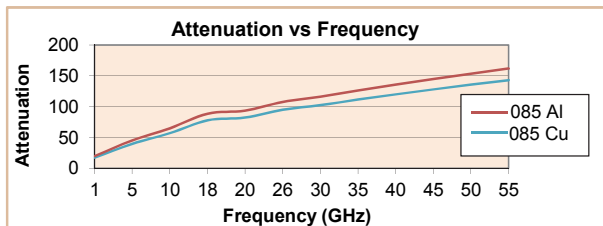

(dB per 100 feet)

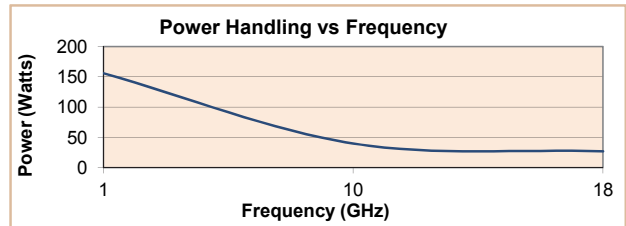

*CW Power in watts at sea level and 23°C

GHz	1	5	10	18	26	30	35	40	45	50	55
085 AL Atten	20	45	65	89	108	116	127	136	145	154	162
085 Cu Atten	17	40	57	78	95	103	112	120	128	136	143

GHz	1	10	18
Pow.	156	40	27

.141 Low Loss Semi-Rigid

AL141LLSP AL141LLTP LL141 LL141TP

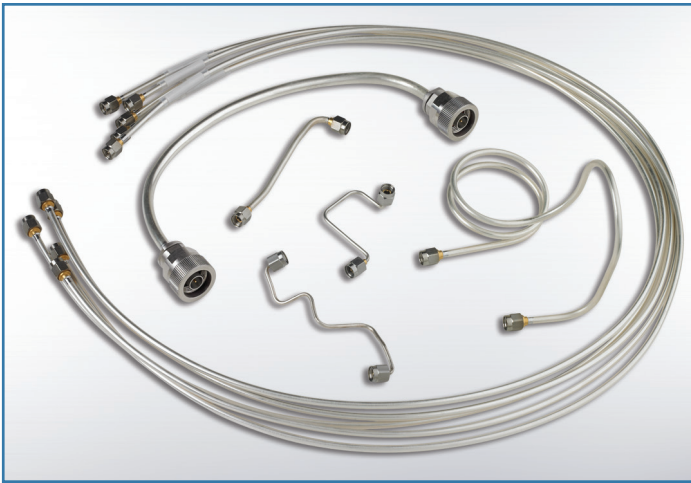

Description:

This widely used .141" diameter Low Loss cable offers a wide range of connectors from GPO to Type N. This low loss cable is specially suited for high reliability applications, especially when temperature changes are a concern. Our special low-density dielectric is very stable in this environment while also offering mechanical durability during any forming of the outer jacket.

Features/Benefits:

- Mode Free Operation to 35 GHz
- Superior Shielding Effectiveness - 100dB Min.
- Stainless Steel Connectors
- Copper Jacket Bare or Tin Finish
- Aluminum Jacket Bare or Tin Finish
- High Vibration Resistance
- Aluminum 40% Lighter Weight than Copper

Applications:

- Instrumentation
- High Frequency Interconnects
- Satellite Component Interconnects

Standard Connectors:

Connector Code	Series	Gender	Type	Loss per GHz	Frequency Max GHz
KMS	2.9mm	Male	Straight	0.01	40
SMS	SMA	Male	Straight	0.01	18
SMR	SMA	Male	R/A	0.02	18
TMS	TNC	Male	Straight	0.01	18

Standard Options:

Option Code	Option Description
W	Weatherized
N	Neoprene
±2.8PS	Phase Matched (+/-2.8 picoseconds)

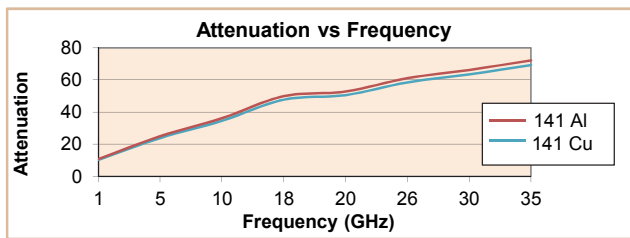

(dB per 100 feet)

GHz	1	5	10	18	20	26	30	35
141 Al Atten	11	25	36	50	53	61	66	72
141 Cu Atten	10	24	35	48	51	59	64	69

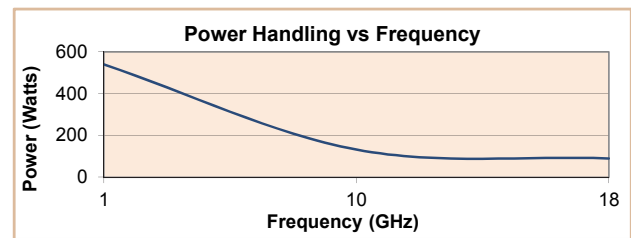

*CW Power in watts at sea level and 23°C

GHz	1	10	18
Pow.	540	132	90

.250 Low Loss Semi-Rigid

AL250LLSP 250LLTP

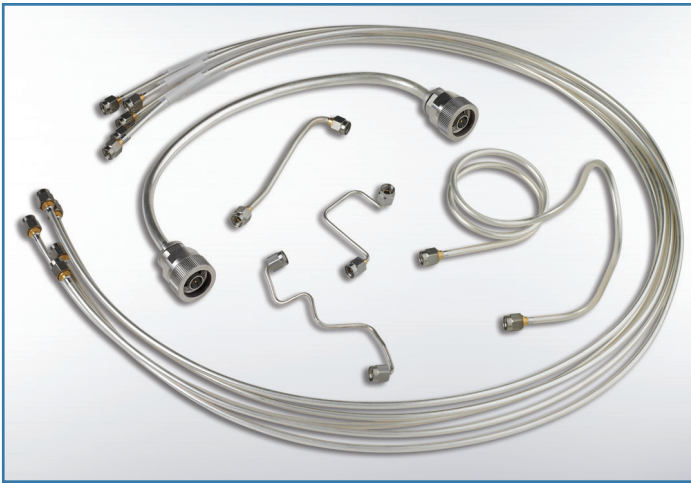

Description:

Our .250" diameter Low Loss Semi-Rigid cable is used where power and lower loss are required with the reliability and shielding of a Semi-Rigid cable. Larger Connectors such as Type N and TNC with extended Performance to 18 GHz offer excellent power handling performance.

Features/Benefits:

- Mode Free Operation to 18 GHz
- Superior Shielding Effectiveness - 100dB Min.
- Stainless Steel Connectors
- Copper Jacket Bare or Tin Finish
- Aluminum Jacket Bare or Tin Finish
- High Vibration Resistance
- Aluminum 40% Lighter Weight than Copper

Applications:

- Instrumentation
- Radar Transmitter
- RF Power Generators
- Satcom

Standard Connectors:

Connector Code	Series	Gender	Type	Loss per GHz	Frequency Max GHz
SMS	SMA	Male	Straight	0.01	18
NMS	Type N	Male	Straight	0.011	18
TMS	TNC	Male	Straight	0.01	18
TMR	TNC	Male	R/A	0.02	18

Standard Options:

Option Code	Option Description
W	Weatherized
N	Neoprene
±2.8PS	Phase Matched (+/-2.8 picoseconds)

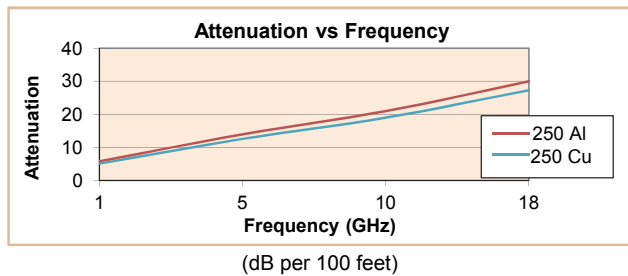

GHz	1	5	10	18
250 Al Atten	6	14	21	30
250 Cu Atten	5	13	19	27

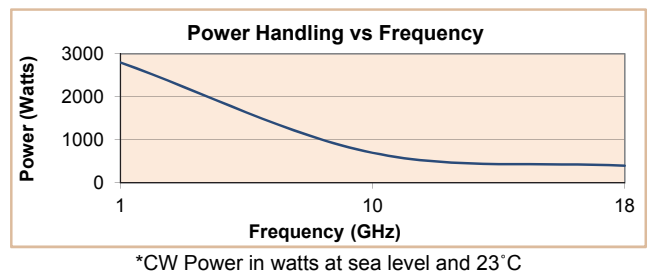

GHz	1	10	18
Pow.	2800	700	400

MIL-C-17 / RG Series Family of cables includes familiar RG cable part numbers that have been superseded by MIL-C-17 numbers and alternative custom cables with improved electrical performance over standard M17 cables. The cables have been grouped by outer diameter, (under .150" and over .150"). In addition, this family of cables contains alternatives to the standard RG cables that offer features like increased flexibility, improved shielding or lower insertion loss.

Features:

- Performance up to 18 GHz
- Cost-Effective Flexible Assemblies
- Construction Variety for Applications Requiring:
 - Increased Flexibility
 - Improved Shielding
 - Lower Insertion Loss

Typical Applications:

- Component Interconnects
- Test Cables
- Jumper Assemblies
- In-Box Assemblies

Available Connectors

This family of cables offers a wide variety of connectors. The available interfaces will be dictated largely by the cable diameter selected. Typical interfaces are: SMA, SSMA, MCX, MMCX and SMB for the smaller diameter cables and Type N, TNC and BNC for the larger diameter cables.



MIL-C-17 | RG Series Family & Alternatives

Specifications - Under 0.150" Diameter

General Specifications	RG316	316D	RD316	SF316
MIL Number	M17/113-RG316	N/A	M17/152-00001	N/A
Diameter	0.098	0.124	0.114	0.110
Frequency, Max (GHz)	3	6	12.4	18
Loss @ 5 GHz (dB/100ft)	N/A	76	63	62

Electrical Specifications	RG316	316D	RD316	SF316
Impedance, Nominal (Ω)	50	50	50	50
Velocity of Propagation (%)	69.5	69.5	69.5	69.5
Shielding Effectiveness, 18 GHz (dB/ft)	>40	>60	>60	>90
Capacitance (pF/ft)	29.4	28.8	29.4	29.4
Delay (ns/ft)	1.46	1.44	1.46	1.46

Mechanical Specifications	RG316	316D	RD316	SF316
Weight (lbs/100ft)	1.2	1.4	1.85	1.3
Temperature Range ($^{\circ}$ C)	-55 to +200	-40 to +105	-55 to +200	-55 to +200
Minimum Bend Radius (inches)	0.4	0.5	0.5	0.5

Temperature Ranges on Standard boots +100 $^{\circ}$ C

Construction Data	RG316	316D	RD316	SF316
Inner Conductor	Stranded SCCS	Stranded SCCS	Stranded SCCS	Stranded SCCS
Dielectric	PTFE	PTFE	PTFE	PTFE
First Outer Shield	SPC Round Braid	SPC Round Braid	SPC Round Braid	SPC Flat Ribbon
Second Outer Shield	N/A	SPC Round Braid	SPC Round Braid	Aluminum Tape
Third Outer Shield	N/A	N/A	N/A	SPC Round Braid
Jacket	FEP	RADOX	FEP	FEP

MIL-C-17 | RG Series Family & Alternatives

Specifications - Over 0.150" Diameter

General Specifications	RG223	RG400	RG142	142D	SF142
MIL Number	M17/84-RG223	M17/128-RG400	M17/60-RG142	N/A	N/A
Diameter	0.212	0.195	0.195	0.195	0.195
Frequency, Max (GHz)	12.4	12.4	18	5	18
Loss @ 5 GHz (dB/100ft)	34	32	32	40	32

Electrical Specifications	RG223	RG400	RG142	142D	SF142
Impedance, Nominal (Ω)	50	50	50	50	50
Velocity of Propagation (%)	66	69.5	70	69	70
Shielding Effectiveness, 18 GHz (dB/ft)	>60	>60	>60	>60	>95
Capacitance (pF/ft)	30.8	29.4	29.4	29	29.4
Delay (ns/ft)	1.54	1.46	1.46	1.44	1.46

Mechanical Specifications	RG223	RG400	RG142	142D	SF142
Weight (lbs/100ft)	4.1	5	4.3	3.99	4.3
Temperature Range ($^{\circ}\text{C}$)	-40 to +85	-55 to +200	-55 to +200	-40 to +105	-55 to +200
Minimum Bend Radius (inches)	1	1	1	1	1

Temperature Ranges on Standard Boots +100 $^{\circ}\text{C}$ Max

Construction Data	RG223	RG400	RG142	142D	SF142
Inner Conductor	Solid SPC	Stranded SPC	Solid SCCS	Solid SPC	Solid SCCS
Dielectric	PE	PTFE	PTFE	SPEX	PTFE
First Outer Shield	SPC Round Braid	SPS Round Braid	SPC Round Braid	SPC Round Braid	SPC Flat Ribbon
Second Outer Shield	SPC Round Braid	SPC Round Braid	SPC Round Braid	SPC Round Braid	Aluminum Tape
Third Outer Shield	N/A	N/A	N/A	N/A	SPC Round Braid
Jacket	PVC	FEP	FEP	RADOX	FEP

MIL-C-17 | RG Series Family & Alternatives

Performance

Attenuation (dB/100ft)				
GHz	RG316	316D	RD316	SF316
0.1	8.0	8.1	8.0	8.0
0.4	16.2	16.6	16.2	16.4
1	26.1	26.8	26.1	26.2
2	37.6	39.0	37.6	38.0
3	46.7	48.6	46.7	47.0
5		64.7	61.7	62.2
6			68.2	66.8
8			80.0	80.7
10			90.7	91.5
12			100.6	101.5
14				111.0
16				120.0
18				128.5

Max Cable Loss at +25° C & Sea Level

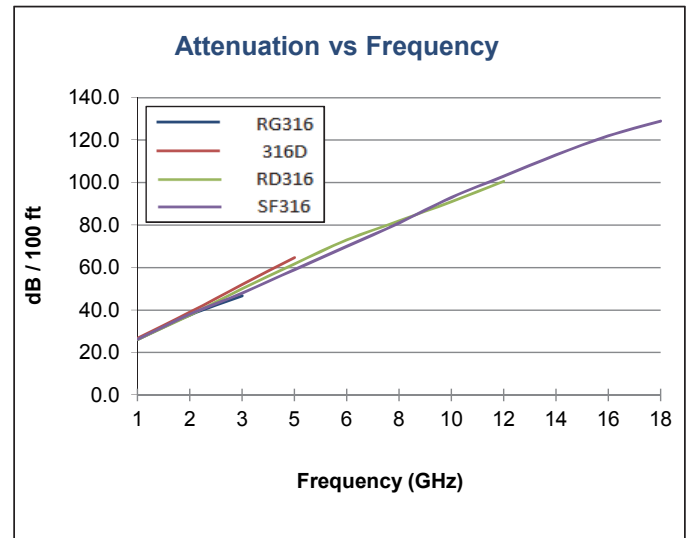

Average Power Rating (Watts)				
GHz	RG316	316D	RD316	SF316
1	173.0	100.0	173.0	178.0
3	93.0	64.0	93.0	96.0
6		49.0	60.0	70.0
8			50.0	52.0
10			40.0	46.0
12			35.0	41.0
14				36.0
16				34.0
18				30.0

Power handling is specified for ambient conditions at sea level and +25° C

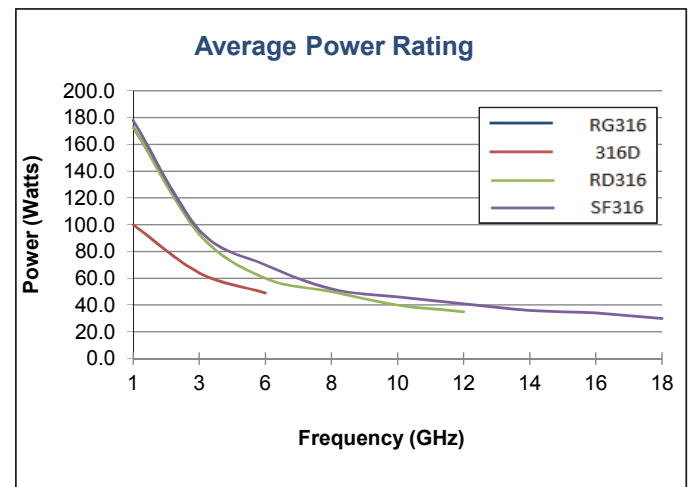

Connector Options				Frequency Max GHz*	Under 0.150"	Over 0.150"
SSMA	Plug	(Male)	Straight	18	SSMS	
SSMA	Plug	(Male)	R/A	18	SSMR	
SMA	Plug	(Male)	Straight	18	SMS	SMS
SMA	Plug	(Male)	R/A	18	SMR	SMR
SMA	Jack	(Female)	Straight	18	SFS	SFS
SMA	Bulkhead	(Female)	Straight	18	SFBS	SFBS
OSSP	Bulkhead	(Female)	Straight	18	OSSPMBS	
OSP	Bulkhead	(Male)	Straight	18	OSPMBS	
Type N	Plug	(Male)	Straight	18	NMS	NMS
Type N	Bulkhead	(Female)	Straight	18	NFBS	NFBS
Type N	Plug	(Male)	R/A	18	NMR	NMR
Type N	Jack	(Female)	Straight	18		NFS
TNC	Plug	(Male)	Straight	18	TMS	TMS
TNC	Plug	(Male)	R/A	18	TMR	TMR
TNC	Bulkhead	(Female)	Straight	18	TFBS	TFBS
TNC	Jack	(Female)	Straight	18		TFS
SMC		(Female)	Straight	6	SMCFS	
MCX	Plug	(Male)	R/A	6	MCXMR	
MCX	Plug	(Male)	Straight	6	MCXMS	
MCX	Jack	(Female)	Straight	6	MCXFS	
MMCX	Plug	(Male)	Straight	6	MMCXMS	
MMCX	Plug	(Male)	R/A	6	MMCXMR	
SMB	Plug	(Male)	Straight	6	SMBMS	
SMB	Plug	(Male)	R/A	6	SMBMR	
SMB	Jack	(Female)	Straight	6	SMBFS	
SMB	Jack	(Female)	R/A	6	SMBFR	
BNC	Plug	(Male)	Straight	4	BMS	BMS
BNC	Plug	(Male)	R/A	4	BMR	BMR
BNC	Bulkhead	(Female)	Straight	4	BFBS	BFBS
BNC	Jack	(Female)	Straight	4		BFS

Gender of the connector is determined by center pin.

Consult sales department for other connectors and options not shown.

*Note: maximum frequency of assembly is dependant on cable and connector.

If operating frequency is over 6 Ghz notify sales department on RFQ.

Cable Assembly Options	Option Code	Under 0.150"	Over 0.150"
Weatherized (Polyolefin)	W	√	√
Weatherized (Neoprene)	N		
Armorized	A		
Armorized & Weatherized (PVC)	AW		
Armorized & Weatherized (Neoprene)	AN		
Armorized & Weatherized (Monocoil & Silicone)	MC		
Armorized & Weatherized (Monocoil & Polyolefin)	MP		
Extended Boots	E	√	√
Phase Matching	±2.8PS	√	√
Dust Caps	D		

MIL-C-17 | RG Series & Alternatives

Options & Ordering Information

Cable Options

E - Extended Boots



W - Weatherized-
Polyolefin



Part Numbering Code

Ordering Information

S M S - R G 1 4 2 - - 1 8 . 0 - S M S ± 2 . 8 P S
CONNECTOR #1 CABLE TYPE OPTION LENGTH (IN.) CONNECTOR #2 OPTION
Blank = None Example:
W = Weatherized 18.0 = 18 inches
P = Phase Matched

Under .150" Diameter Series

Standard Flexible



Description:

Standard Flexible cables under 0.150 inch diameter offer a lightweight and flexible interconnect where loss and power are not a concern. The SF316 cable offers the lowest loss and highest shielding while 316D cable provides great flexibility, useful in test conditions. Stainless steel connectors are available for test cable requirements, but must be specified, if required.

Features/Benefits:

- Includes RG Cables and Their Alternatives
- More Cost-Effective than Low-loss Cable Types
- High Shielding Types Available
- Ultra-Flexible Types Available

Applications:

- Component Interconnects
- Test Cables
- Jumper Assemblies
- In-Box Assemblies

Standard Connectors:

Connector Code	Series	Gender	Type	Loss per GHz	Frequency Max GHz
SMS	SMA	Male	Straight	0.01	18
SMR	SMA	Male	R/A	0.02	18
SFBS	SMA	Female	Straight	0.01	18
SFS	SMA	Female	Straight	0.01	18
NMS	Type N	Male	Straight	0.011	18
NMR	Type N	Male	R/A	0.02	18
NFBS	Type N	Female	Straight	0.01	18
TMS	TNC	Male	Straight	0.01	18
TMR	TNC	Male	R/A	0.02	18
TFBS	TNC	Female	Straight	0.015	18
SMBFR	SMB	Female	R/A	0.02	40
SMBFS	SMB	Female	Straight	0.01	40
MCXMS	MCX	Male	Straight	0.01	6
MCXMR	MCX	Male	R/A	0.02	6
MMCXMS	MMCX	Male	Straight	0.01	6
MMCXMR	MMCX	Male	Straight	0.02	6
BMS	BNC	Male	Straight	0.01	4
BMR	BNC	Male	R/A	0.02	4
BFBS	BNC	Female	Straight	0.01	4
OSPMBS	OSP	Male	Straight	0.01	22
OSSPMBS	OSSP	Male	Straight	0.01	28
SSMS	SSMA	Male	Straight	0.01	34
SSMR	SSMA	Male	R/A	0.02	34

Standard Options:

Option Code	Option Description
W	Weatherized
±2.8PS	Phase Matched (+/-2.8 picoseconds)
E	Extended Boots

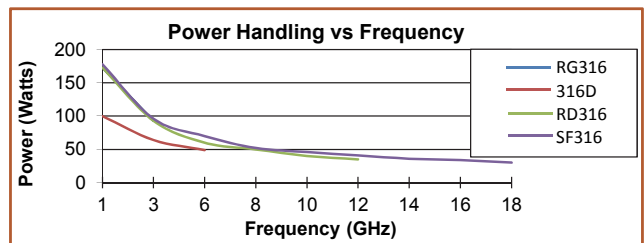
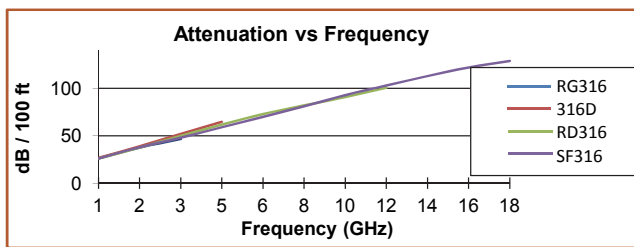

GHz	1	2	3	5	8	12	14	16	18
RG316 Atten	26	38	47						
316D Atten	27	39	49	65					
RD316 Atten	26	38	47	62	80	101			
SF316 Atten	26	38	47	62	81	102	111	120	129

GHz	1	3	6	8	10	12	14	16	18
RG316 Power	173	93							
316D Power	100	64	49						
RD316 Power	173	93	60	50	40	35			
SF316 Power	178	96	70	52	46	41	36	34	30

Over .150" Diameter Series

Standard Flexible



Standard Connectors:

Connector Code	Series	Gender	Type	Loss per GHz	Frequency Max GHz
SMS	SMA	Male	Straight	0.01	18
SMR	SMA	Male	R/A	0.02	18
SFBS	SMA	Female	Straight	0.01	18
SFS	SMA	Female	Straight	0.01	18
NMS	Type N	Male	Straight	0.011	18
NMR	Type N	Male	R/A	0.02	18
NFBS	Type N	Female	Straight	0.01	18
TMS	TNC	Male	Straight	0.01	18
TMR	TNC	Male	R/A	0.02	18
TFBS	TNC	Female	Straight	0.015	18
BMS	BNC	Male	Straight	0.01	4
BMR	BNC	Male	R/A	0.02	4
BFBS	BNC	Female	Straight	0.01	4

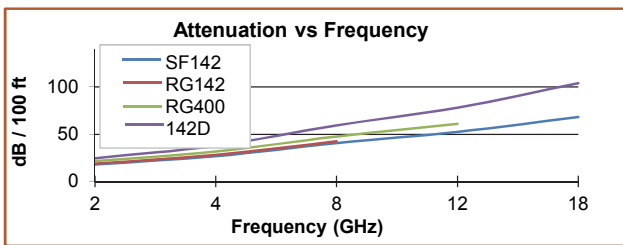

(dB per 100 feet)

GHz	2	4	8	12	18
SF142 Atten	18	27	41	53	68
RG142 Atten	19	28	43		
RG400 Atten	22	32	48	61	
142D Atten	25	38	59	78	104

Description:

Standard Flexible cables over 0.150 inch diameter offer a moderate weight and flexible interconnect where loss or power may be a concern and cannot be met with smaller diameter cables. SF142 cable offers the lowest loss and highest shielding while 142D cable provides great flexibility useful in some test conditions. Stainless steel connectors are available for test cable requirements, (stainless steel must be specified).

Features/Benefits:

- Includes RG Cables and Their Alternatives
- More Cost-Effective than Low-loss Cable Types
- High Shielding Types Available
- Ultra-Flexible Types Available

Applications:

- Component Interconnects
- Test Cables
- Jumper Assemblies
- In-Box Assemblies

Standard Options:

Option Code	Option Description
W	Weatherized
±2.8PS	Phase Matched (+/-2.8 picoseconds)
E	Extended Boots

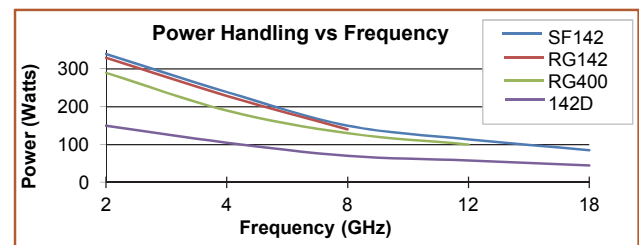

*CW Power in watts at sea level and 23°C

GHz	2	4	8	12	18
SF142 Power	340	239	150	114	85
RG142 Power	330	229	140		
RG400 Power	290	190	130	100	
142D Power	150	105	70	58	45

LMR® Cable Assemblies are the most suitable selection for interconnect applications up to 5.8 GHz. They offer low loss and high shielding at very reasonable costs. Typical connector types are: SMA, TNC, Type N, BNC, and UHF.

Features:

- Low Loss
- DC to 5.8 GHz
- Phase Matched Sets Available
- Water Tight Jacket Available
- L240DB & L400DB
- UltraFlex (Stranded Center Conductor) Available
L240UF & L400UF
- Plenum Rated Available

Typical Applications:

- Interconnects
- Land Mobile
- Cellular
- Paging
- PCS
- 2-way Radio
- LMDS
- WLL
- CLEC
- ISM
- Wireless Telemetry
- Base Stations
- Mobile Antennas



LMR® Family

Specifications

General Specifications	LMR-100A	LMR-195	LMR-240	LMR-400
Diameter	0.11	0.195	0.24	0.405
Frequency, Max (GHz)	5.8	5.8	5.8	5.8
Loss @ 5.8 GHz (dB/100ft)	64.1	29.9	20.4	10.8

Electrical Specifications	LMR-100A	LMR-195	LMR-240	LMR-400
Impedance, Nominal (Ω)	50	50	50	50
Velocity of Propagation (%)	66	76	84	85
Shielding Effectiveness (dB/ft)	>90	>90	>90	>90
Capacitance (pF/ft)	30.8	25.4	24.2	23.9
Delay (ns/ft)	1.54	1.27	1.21	1.2

Mechanical Specifications	LMR-100A	LMR-195	LMR-240	LMR-400
Weight (lbs/100ft)	0.92	2.1	3.4	6.8
Temperature Range ($^{\circ}$ C)	-40 to 85	-40 to 85	-40 to 85	-40 to 85
Minimum Bend Radius (inches)	0.25	0.5	0.75	1

Construction Data	LMR-100A	LMR-195	LMR-240	LMR-400
Inner Conductor	Bare Copper Clad Steel	Bare Copper	Bare Copper	Bare Copper Clad Aluminum
Dielectric	Polyethylene	Foam Polyethylene	Foam Polyethylene	Foam Polyethylene
First Outer Shield	Aluminum Tape	Aluminum Tape	Aluminum Tape	Aluminum Tape
Second Outer Shield	Tinned Copper	Tinned Copper	Tinned Copper	Tinned Copper
Third Outer Shield	N/A	N/A	N/A	N/A
Jacket	Extruded PVC	Extruded Polyethylene	Extruded Polyethylene	Extruded PE

Attenuation (dB/100ft)				
GHz	LMR-100	LMR-195	LMR-240	LMR-400
0.03	3.9	2.0	1.3	0.7
0.05	5.1	2.5	1.7	0.9
0.15	8.9	4.4	3.0	1.5
0.22	10.9	5.4	3.7	1.9
0.45	15.8	7.8	5.3	2.7
0.90	22.8	11.1	7.6	3.9
1.50	30.1	14.5	9.9	5.1
1.80	33.2	16.0	10.9	5.7
2.00	35.2	16.9	11.5	6.0
2.50	39.8	19.0	12.9	6.8
5.80	64.1	29.9	20.4	10.8

Max Cable Loss at +25° C & Sea Level

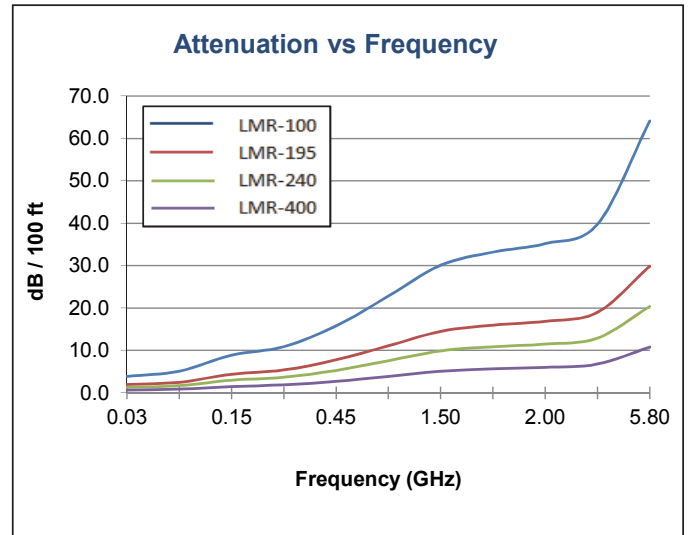

Average Power Rating (Watts)				
GHz	LMR-100	LMR-195	LMR-240	LMR-400
0.03	230	890	1490	3330
0.05	180	680	1150	2570
0.15	100	390	660	1470
0.22	83	320	540	1200
0.45	57	220	380	830
0.90	39	260	260	580
1.50	29	120	200	440
1.80	27	110	180	400
2.00	25	100	170	370
2.50	22	90	150	330
5.80	13	60	100	210

Power handling is specified for ambient conditions at sea level and +25° C

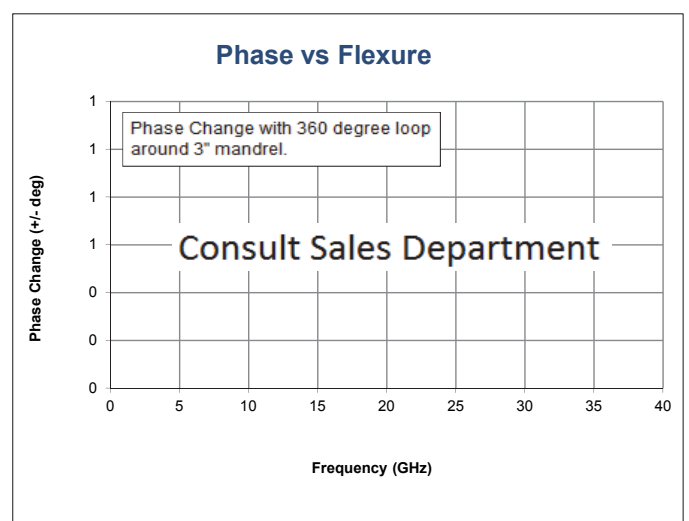
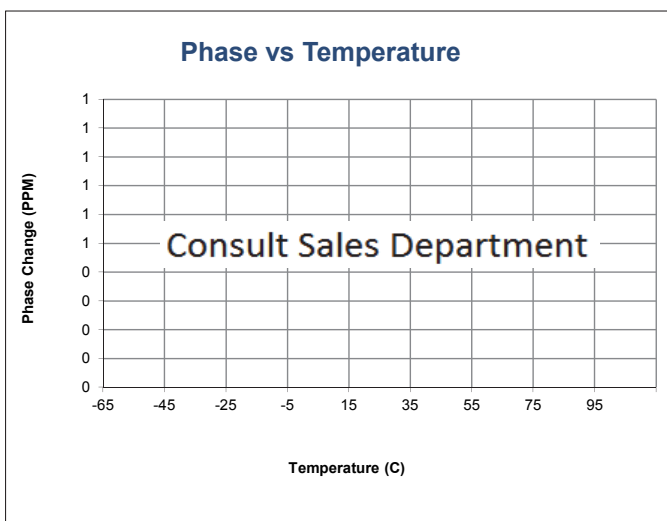
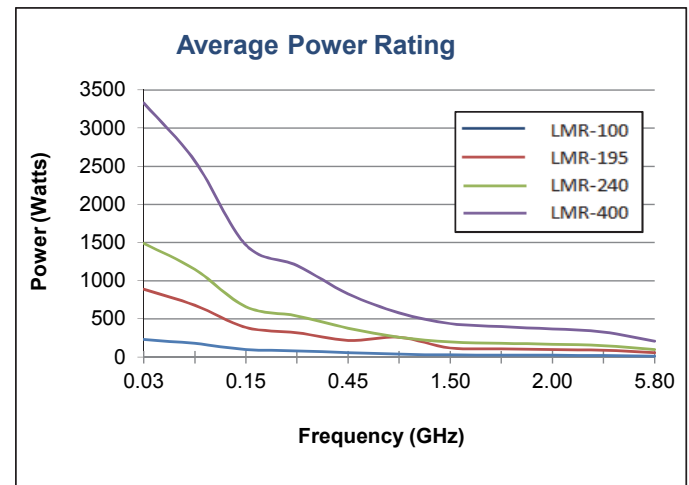

LMR® Family

Connector Selection & Options

Connector Options				Frequency Max GHz*	LMR-100A	LMR-195	LMR240	LMR-400
Type N	Plug	(Male)	Straight	5.8	NMS	NMS	NMS	NMS
Type N	Plug	(Male)	R/A	5.8	NMR	NMR	NMR	NMR
Type N	Bulkhead	(Female)	Straight	5.8	NFBS	NFBS	NFBS	NFBS
Type N	Jack	(Female)	Straight	5.8		NFS		NFS
SMA	Plug	(Male)	Straight	5.8	SMS	SMS	SMS	SMS
TNC	Plug	(Male)	Straight	5.8	TMS	TMS	TMS	TMS
TNC	Plug	(Male)	R/A	5.8	TMR	TMR	TMR	TMR
BNC	Plug	(Male)	Straight	4	BMS	BMS	BMS	BMS

Gender of the connector is determined by center pin.

Consult sales department for other connectors and options not shown.

** Max Frequency of connectors may be limited by the cable selected.*

*** Extended Boots Available : Option E**

*** Dust Caps Available: Option D**

*** Armored Protective Covering Available: Option A**

Cable Options

E - Extended Boots



A - Armored



D - Dust Caps



Part Numbering Code

Ordering Information

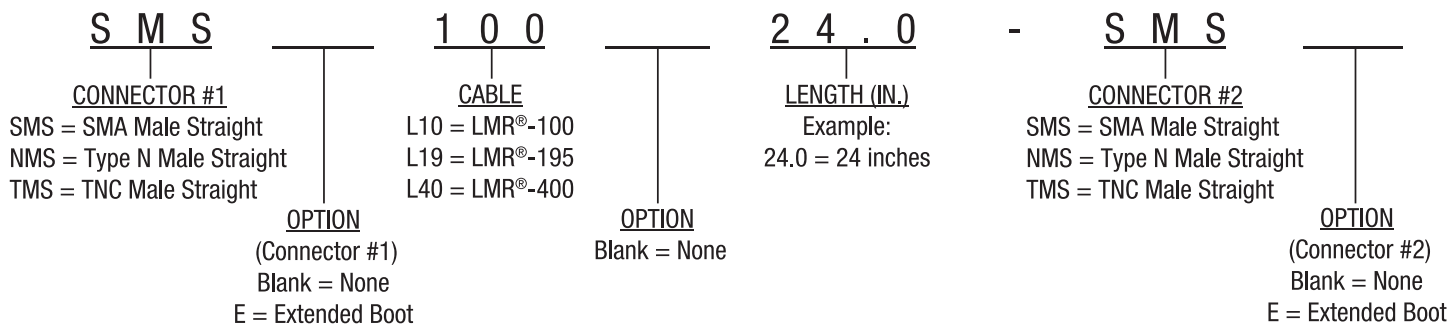

LMR® 100A

Flexible Communications Coax



Description:

LMR®-100A has a PVC Jacket and is designed for Low-Loss general purpose indoor / outdoor applications and is somewhat more flexible than the standard polyethylene jacketed LMR.

Features/Benefits:

Drop-in Replacement for RG-316/RG-174
Enhanced Flexibility when compared to standard LMR
Most Suitable for Applications up to 5.8 GHz
Low Loss & High Shielding at Very Reasonable Cost.

Applications:

Jumpers
Short Antenna Feeder runs
Mobile Antennas
GPS
WLAN
WiMax

Standard Connectors:

Connector Code	Series	Gender	Type	Loss per GHz	Frequency Max GHz
NMS	Type N	Male	Straight	0.01	5.8
NMR	Type N	Male	R/A	0.015	5.8
NFBS	Type N	Female	Straight	0.012	5.8
SMS	SMA	Male	Straight	0.01	5.8
SMR	SMA	Male	Straight	0.015	5.8
SFBS	SMA	Female	Straight	0.01	5.8
TMS	TNC	Male	Straight	0.01	5.8
TMR	TNC	Male	R/A	0.015	5.8
TFBS	TNC	Female	Straight	0.012	5.8
MCXMR	MCX	Male	R/A	0.01	5.8
MCXFS	MCX	Female	Straight	0.01	5.8
BMS	BNC	Male	Straight	0.01	4

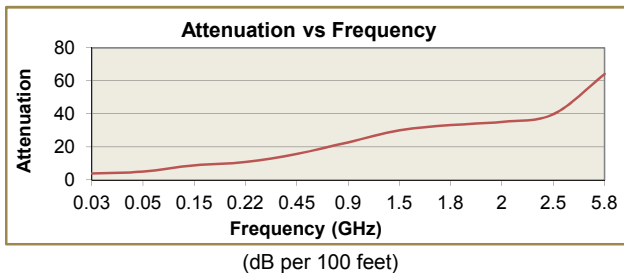

GHz	0.03	0.05	0.15	0.22	0.45	0.90	1.50	1.80	2.00	2.50	5.80
Atten	3.9	5.1	8.9	10.9	15.8	22.8	30.1	33.2	35.2	39.8	64.1

Standard Options:

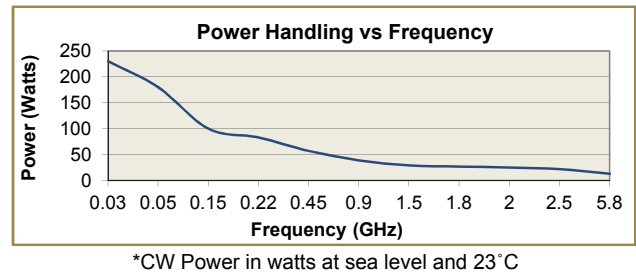

GHz	0.03	0.05	0.15	0.22	0.45	0.90	1.50	1.80	2.00	2.50	5.80
Pow.	230	180	100	83	57	39	29	27	25	22	13

Flexible Communications Coax



Description:

LMR®-195 standard is a UV Resistant Polyethylene jacketed cable designed for 20-year service outdoor use. The bending and handling characteristics are significantly better than air-dielectric and corrugated hard-line cables

Features/Benefits:

- Drop-in Replacement for RG-58/RG-142
- Flexible Outer Conductor Enables Tight Bend Radius.
- Most Suitable for Applications up to 5.8 GHz
- Low Loss & High Shielding at Very Reasonable Cost.

Applications:

- Jumpers
- Short Antenna Feeder runs
- Mobile Antennas
- GPS
- WLAN
- WiMax

Standard Connectors:

Connector Code	Series	Gender	Type	Loss per GHz	Frequency Max GHz
NMS	Type N	Male	Straight	0.01	5.8
NMR	Type N	Male	R/A	0.015	5.8
NFBS	Type N	Female	Straight	0.012	5.8
SMS	SMA	Male	Straight	0.01	5.8
SMR	SMA	Male	Straight	0.015	5.8
SFS	SMA	Female	R/A	0.01	5.8
SFBS	SMA	Female	Straight	0.01	5.8
TMS	TNC	Male	Straight	0.01	5.8
TMR	TNC	Male	R/A	0.015	5.8
TFBS	TNC	Female	Straight	0.012	5.8
BMS	BNC	Male	Straight	0.01	4
BMR	BNC	Male	R/A	0.015	4
BFBS	BNC	Female	Straight	0.012	4

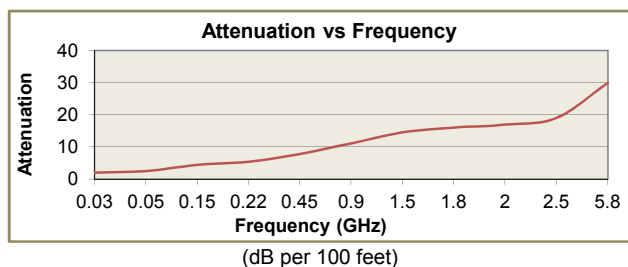

GHz	0	0.1	0.2	0.5	0.9	1.5	1.8	2.0	2.5	5.8
Atten	2.0	2.5	4.4	5.4	7.8	11.1	14.5	16.0	16.9	29.9

Standard Options:

Option Code	Option Description
A	Armorized
D	Dust Caps
E	Extended Boots

Variations:

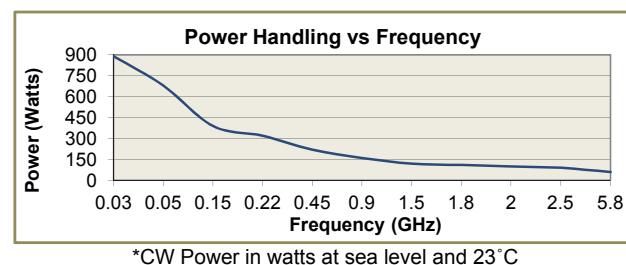

GHz	0	0.1	0.2	0.5	0.9	1.5	1.8	2.0	2.5	5.8
Pow.	890	680	390	320	220	160	120	110	100	60

LMR® 240

Flexible Communications Coax



Description:

LMR®-240 standard is a UV Resistant Polyethylene jacketed cable designed for 20-year service outdoor use. The bending and handling characteristics are significantly better than air-dielectric and corrugated hard-line cables.

Features/Benefits:

Flexible Outer Conductor Enables Tight Bend Radius.
Most Suitable for Applications up to 5.8 GHz
Low Loss & High Shielding at Very Reasonable Cost.

Applications:

- Jumpers
- Short Antenna Feeder runs
- Mobile Antennas
- GPS
- WLAN
- WiMax

Standard Connectors:

Connector Code	Series	Gender	Type	Loss per GHz	Frequency Max GHz
NMS	Type N	Male	Straight	0.01	5.8
NMR	Type N	Male	R/A	0.015	5.8
NFBS	Type N	Female	Straight	0.012	5.8
SMS	SMA	Male	Straight	0.01	5.8
SMR	SMA	Male	Straight	0.015	5.8
SFBS	SMA	Female	Straight	0.01	5.8
TMS	TNC	Male	Straight	0.01	5.8
TMR	TNC	Male	R/A	0.015	5.8
TFBS	TNC	Female	Straight	0.012	5.8
BMS	BNC	Male	Straight	0.01	4

Standard Options:

Option Code	Option Description
A	Armorized
D	Dust Caps
E	Extended Boots

Variations:

Part Number	Cable Code	Description
LMR-240UF	L240UF	Stranded Center Conductor
LMR-240LLPL	L240LLPL	Plenum Rated
LMR-240DB	L240DB	Water Tight Jacket

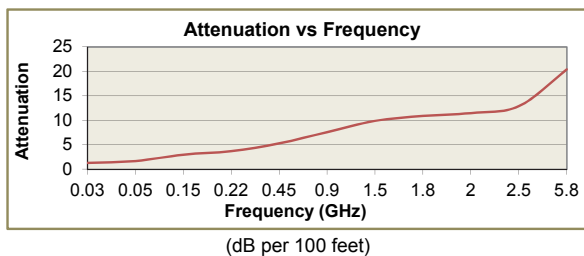

GHz	0.03	0.05	0.15	0.22	0.45	0.90	1.50	1.80	2.00	2.50	5.80
Atten	1.3	1.7	3	3.7	5.3	7.6	9.9	11	12	13	20

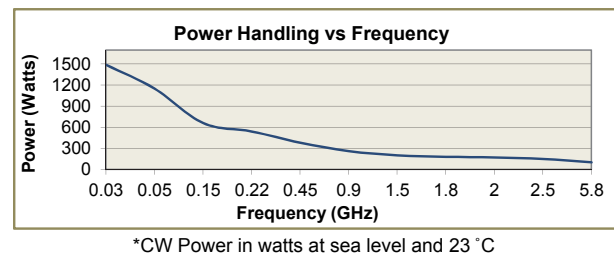

GHz	0.03	0.05	0.15	0.22	0.45	0.90	1.50	1.80	2.00	2.50	5.80
Pow.	1490	1150	660	540	380	260	200	180	170	150	100



Description:

LMR®-400 standard is a Polyethylene jacketed cable designed for 20-year service outdoor use and incorporates the best materials for UV Resistance. Low Loss is a hallmark feature of the LMR®-400.

Features/Benefits:

- Drop-in Replacement for RG-8/9913 Air-Dielectric Cable.
- Flexible Outer Conductor Enables Tight Bend Radius
- Most Suitable for Applications up to 5.8 GHz.
- Low Loss & High Shielding at Very Reasonable Cost.

Applications:

- Jumpers
- Short Antenna Feeder runs
- Mobile Antennas
- GPS
- WLAN
- WiMax

Standard Connectors:

Connector Code	Series	Gender	Type	Loss per GHz	Frequency Max GHz
NMS	Type N	Male	Straight	0.01	5.8
NMR	Type N	Male	R/A	0.015	5.8
NFBS	Type N	Female	Straight	0.012	5.8
SMS	SMA	Male	Straight	0.01	5.8
TMS	TNC	Male	Straight	0.01	5.8
TMR	TNC	Male	R/A	0.015	5.8
BMS	BNC	Male	Straight	0.01	4

Standard Options:

Option Code	Option Description
A	Armorized
D	Dust Caps
E	Extended Boots

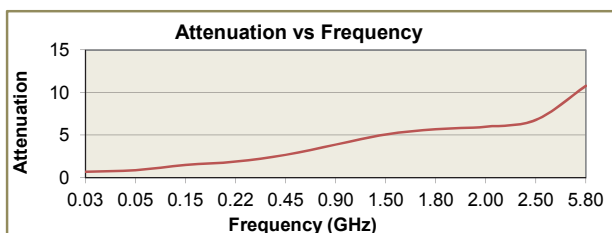

(dB per 100 feet)

GHz	0.03	0.05	0.15	0.22	0.45	0.90	1.50	1.80	2.00	2.50	5.80
Atten	0.7	0.9	1.5	1.9	2.7	3.9	5.1	5.7	6	6.8	11

Variations:

Part Number	Cable Code	Description
LMR-400UF	L400UF	Stranded Center Conductor
LMR-400LLPL	L400LLPL	Plenum Rated
LMR-400DB	L400DB	Water Tight Jacket

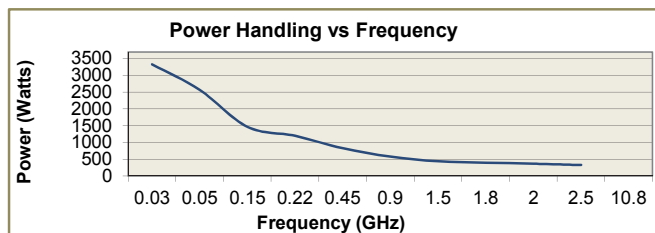

*CW Power in watts at sea level and 23°C

GHz	0.03	0.05	0.15	0.22	0.45	0.90	1.50	1.80	2.00	2.50	5.80
Pow.	3330	2570	1470	1200	830	580	440	400	370	330	210

Armored Overall Length



Cable Option - A An armored protective covering constructed of a flexible stainless steel armor that is installed over the entire length of the cable jacket and locked in place from connector to connector. This prevents damage to the cable from being stepped on or run over by light equipment and prevents cable kinking throughout the assembly. Also adds 20-30 dB of shielding effectiveness.

Typical Applications:

- Production and Lab Testing
- Environmental Testing
- Outdoor Installations

Typical Properties

Armor Material	Stainless Steel 304 alloy
Construction	SquareLok & InterLok style

Armored Overall Length Protective Covering (Optional)

Cable Code	Option Code	Description	Diameter Outside	Bend Radius	Break lbs/linear	Crush* lbs/inch	Weight lbs/100 ft
160	A	Armor 7/32	0.303	0.9	155	434	3.3
180SP	A	Armor 1/4	0.329	1.0	250	286	4.6
200	A	Armor 1/4	0.329	1.0	250	286	4.6
235SP	A	Armor 5/16	0.410	1.0	200	280	5.5
290	A	Armor 3/8	0.500	1.0	225	525	8.8
335	A	Armor 3/8	0.500	1.0	225	525	8.8
335SP	A	Armor 3/8	0.500	1.0	225	525	8.8
490S	A	Armor 1/2	0.625	1.3	250	400	10.6

Properties information is typical data only and should not be used for specification requirements.

* Crush strength test per ISO 15465-2003 Section 7.2.

Consult Sales Department for others types of covering.

Cable Assembly Options

Option - Z

Weatherized Overall Length



Cable Option - Z Our “Weather-proof Sealing” Technique ensures a water tight barrier between the connector back body and the cable jacket. **This option is standard with all available weatherized configurations** including, Weatherized PVC (Option - W), Neoprene (Option - N), and Armored Weatherized (Option - AW). *Stand alone “Weather-Proof Sealing” (Option - Z) does not include UV protection of the cable and is available for Lab-Flex® and Lab-Flex® S families.

Typical Applications:

- Production and Lab Testing
- Environmental Testing
- Harsh Chemical Environments
- Outdoor Testing

Option - Z Inclusion		
Available Options	Automatically Included	Description
Option - A (Armored)		
Option - AW (Armored & Weatherized)	√	"Z" does not have to be called out in cable code.
Option - MC (Monocoil)		
Option - MP (Armored Monocoil)		
Option - W (Weatherized)	√	"Z" does not have to be called out in cable code.
Option - N (Neoprene)	√	"Z" does not have to be called out in cable code.

* Note:

Option - Z is also available for all Lab-Flex® & Lab-Flex® S that are not provided with Weatherization (Option - W), Neoprene (Option - N) or Armored & Weatherized (Option AW), to order add “Z” after cable code.

Example: SMS - 200Z - 48.0 - SMS

Weatherized Overall Length



Cable Option - W The Weatherized option for Lab-Flex® series consists of a polyolefin (shrink tubing) jacket or PVC extruded over the entire length of the cable jacket to provide additional protection from UV, moisture and other elements encountered in outdoor applications. All connectors when mated are assured to be water tight using our “Weather Proof Sealing” Technique (Option - Z) not relying on traditional heat shrink booting.

Now Lab-Flex® series “W” offers a polyolefin (shrink tubing) jacket that protects from shorting and additional protection from UV.

Typical Applications:

- Production and Lab Testing
- Environmental Testing
- Outdoor Environments

Typical Properties (Polyolefin)	
Jacket Material	Polyolefin (Shrink Tube)
Temperature Rating (°C)	-55 to +135
Tensile Strength	2400 PSI
Heat Aging	336 HRS @ 175°C = 175% Elongation
Heat Shock	4 HRS @ 250°C = No Dripping or Cracking
Low Temperature. Flexibility	4 HRS @ -55°C = No Cracking
Flammability	Self Extinguishing
Corrosive Effect	Non-Corrosive
Solvent Resistance	Tensile Strength = 1000 PSI
Water Absorption	0.20%
Fungus Resistance	Non-Nutrient

Meets the following specifications: MIL-I-23053/5, CLASS 1, 2; AMS-3636; AMS-3637; UL; CSA

Typical Properties (PVC)		
Jacket Material	PVC (Extruded Thermoplastic Elastomer)	
Temperature Rating (°C)	-20 to +135	
Specific Gravity	1.36	ASTM-D-792
Durometer (Shore "A" Sec.)	70	ASTM-D-1709
Tensile Strength (psi)	2,100	ASTM-D-638
Elongation (%)	350	ASTM-D-638
Brittle Point (°C)	-42	ASTM-D-746
Oxygen (%)	38.0	ASTM-D-2863

Weatherized Overall Length Protective Covering (Optional)				
Cable Code	Option Code	Description	Diameter Outside	Weight lbs/100 ft
100	W	Polyolefin (Shrink Tubing)	0.14	1.29
125	W	Polyolefin (Shrink Tubing)	0.16	2.44
160	W	PVC (Extruded)	0.21	3.70
200	W	PVC (Extruded)	0.31	6.75
290	W	PVC (Extruded)	0.40	11.02
335	W	PVC (Extruded)	0.47	14.24

Properties information is typical data only and should not be used for specification requirements.

* Crush strength test per ISO 15465-2003 Section 7.2.

Consult Sales Department for others types of covering.

Cable Assembly Options

Option - AW

Armored & Weatherized Overall Length



Cable Option - AW An armored protective covering constructed of a flexible stainless steel armor that is installed over the entire length of the cable jacket and locked in place from connector to connector. This prevents damage to the cable from being stepped on or run over by light equipment and prevents cable kinking throughout the assembly. Then a PVC jacket is extruded over the entire length of stainless steel armor, to prevent dirt, water and other elements from penetrating into the armor. Also adds 20-30 dB of shielding effectiveness.

Typical Applications:

- Production and Lab Testing
- Environmental Testing
- Outdoor Installations

Typical Properties

Armor Material	Stainless Steel 304 alloy	
Jacket Material	Thermoplastic Elastomer (PVC)	
Temperature Rating	-20 to +135	
Specific Gravity	1.36	ASTM-D-792
Durometer (Shore "A" Sec.)	70	ASTM-D-1709
Tensile Strength (psi)	2,100	ASTM-D-638
Elongation (%)	350	ASTM-D-638
Brittle Point (°C)	-42	ASTM-D-746
Oxygen (%)	38.0	ASTM-D-2863

Armored & Weatherized Overall Length Protective Covering (Optional)

Cable Code	Option Code	Description	Diameter Outside	Bend Radius	Break lbs/linear	Crush* lbs/inch	Weight lbs/100 ft
160	A	Armor 7/32 PVC Jacket	0.40	0.90	155	434	7.79
180SP	A	Armor 1/4 PVC Jacket	0.44	1.00	250	286	7.89
200	A	Armor 1/4 PVC Jacket	0.44	1.00	250	286	7.89
235SP	A	Armor 5/16 PVC Jacket	0.52	1.00	200	280	9.48
290	A	Armor 3/8 PVC Jacket	0.61	1.00	225	525	13.11
335	A	Armor 3/8 PVC Jacket	0.61	1.00	225	525	13.11
335SP	A	Armor 3/8 PVC Jacket	0.61	1.00	225	525	13.11
490S	A	Armor 1/2 PVC Jacket	0.74	1.25	250	400	17.24

Properties information is typical data only and should not be used for specification requirements.

* Crush strength test per ISO 15465-2003 Section 7.2.

Consult Sales Department for others types of covering.

Weatherized Overall Length



Cable Option - N This option for Lab-Flex® series consists of Neoprene jacket over the entire length of the cable to provide additional protection from UV, moisture and other elements encountered in outdoor applications. All connectors when mated are assured to be water tight using our “Weather Proof Sealing” Technique (Option - Z) not relying on traditional heat shrink booting.

Typical Applications:

- Outdoor Testing
- Environmental Testing
- Harsh Chemical Environments

Typical Properties (Neoprene)	
Jacket Material	Neoprene shrink tube
Temperature Rating (°C)	-75 to +200
Tensile Strength	
Heat Aging	
Heat Shock	4 HRS @ 200°C = No Dripping or Cracking
Low Temperature. Flexibility	4 HRS @ -75°C = No Cracking
Flammability	Self Extinguishing
Corrosive Effect	Non-Corrosive
Solvent Resistance	Tensile Strength = 1000 PSI
Water Absorption	
Fungus Resistance	

Meets the following specifications: MIL-I-23053/1, CLASS 1 & 2; AMS-3623; UL; MIL-R-49846, CLASS 1

Weatherized Overall Length Protective Covering (Optional)				
Cable Code	Option Code	Description	Diameter Outside	Weight lbs/100 ft
100	N	Neoprene (Shrink Tubing)	0.12	1.38
125	N	Neoprene (Shrink Tubing)	0.15	2.38
160	N	Neoprene (Shrink Tubing)	0.21	3.38
200	N	Neoprene (Shrink Tubing)	0.25	6.30
290	N	Neoprene (Shrink Tubing)	0.34	8.53
335	N	Neoprene (Shrink Tubing)	0.39	9.81

Properties information is typical data only and should not be used for specification requirements. Consult Sales Department for others types of covering.

Cable Assembly Options

Option - MC

Monocoil Overall Length



Cable Option - MC Monocoil armor is made from a flat T-304 stainless steel strip, spiral wound to form a long spring like tube. A layer of braided fiberglass is added to prevent armor tubing from stretching. The jacket is an extruded elastomer silicone rubber to prevent dirt, water and other elements from penetrating into the armor.

Typical Applications:

- Production and Lab Testing
- Environmental Testing

Monocoil Style



Typical Properties

Armor Material	Stainless Steel 304 alloy
Armor Construction	Spiral Wound Spring Tube
Inner Layer	Fiberglass Braid
Jacket Material	Extruded Elastomer Silicone Rubber
Temperature Rating (°C)	-50 to +200

Armored & Weatherized Overall Length Protective Covering (Optional)

Cable Code	Option Code	Description	Diameter Outside	Bend Radius	Break lbs/linear	Crush* lbs/inch	Weight lbs/100 ft
105	MC	SST Monocoil Armor & Jacket	0.22	0.38	-	500	2.67
160	MC	SST Monocoil Armor & Jacket	0.30	0.50	-	-	5.24
180SP	MC	SST Monocoil Armor & Jacket	0.38	0.50	-	-	6.94
200	MC	SST Monocoil Armor & Jacket	0.38	0.63	-	-	6.94
235SP	MC	SST Monocoil Armor & Jacket	0.41	0.69	-	-	7.00
290	MC	SST Monocoil Armor & Jacket	0.47	0.75	-	-	7.25

Properties information is typical data only and should not be used for specification requirements.

* Crush strength test per ISO 15465-2003 Section 7.2.

Consult Sales Department for others types of covering.

Light Gauge Armor & Weatherized Overall Length



Cable Option - MP Monocoil armor is made from a flat T-304 stainless steel strip, spiral wound to form a long spring-like tube. A polyolefin jacket (shrink tubing) is applied over the length of the stainless steel armor prevent dirt, water and other elements from penetrating into the

armor.

Typical Applications:

- Production and Lab Testing
- Environmental Testing

Monocoil Style



Typical Properties	
Armor Material	Stainless Steel 304 alloy
Armor Construction	Spiral Wound Spring Tube
Inner Layer	N/A
Jacket Material	Polyolefin shrink tube
Temperature Rating (°C)	-55 to +135

Armored & Weatherized Overall Length Protective Covering (Optional)							
Cable Code	Option Code	Description	Diameter Outside	Bend Radius	Break lbs/linear	Crush* lbs/inch	Weight lbs/100 ft
105	MP	SST Monocoil Armor & Polyolefin Jacket	0.19	0.25	N/A	500	3.09
160	MP	SST Monocoil Armor & Polyolefin Jacket	0.25	0.50	N/A	-	3.31
180SP	MP	SST Monocoil Armor & Polyolefin Jacket	0.29	0.63	N/A	-	4.41
200	MP	SST Monocoil Armor & Polyolefin Jacket	0.29	0.63	N/A	-	4.41
235SP	MP	SST Monocoil Armor & Polyolefin Jacket	0.30	0.69	N/A	-	5.51
290	MP	SST Monocoil Armor & Polyolefin Jacket	0.38	0.75	N/A	-	7.05

Properties information is typical data only and should not be used for specification requirements.

* Crush strength test per ISO 15465-2003 Section 7.2.

Consult Sales Department for others types of covering.

Cable Assembly Options

Option - D



Cable Option - D Dust caps help protect connector mating interfaces from contaminants in harsh environments when cables are not in use. They also prevent physical damage to mating pins during transportation and storage.

Typical Applications:

- Outdoor RF Communication Equipment
- Dusty Environments
- Chemical Environments

Dust Caps (Optional)		
Connector Code	Option Code	Description
SMS	D	SMA Series Connector
SMR	D	SMA Series Connector
SFBS	D	SMA Series Connector
SFS	D	SMA Series Connector
TMS	D	TNC Series Connector
TMR	D	TNC Series Connector
TFBS	D	TNC Series Connector
TFS	D	TNC Series Connector
NMS	D	Type N Series Connector
NMR	D	Type N Series Connector
NFBS	D	Type N Series Connector
NFS	D	Type N Series Connector
NFFS	D	Type N Series Connector
BMS	D	BNC Series Connector
BMR	D	BNC Series Connector
BFBS	D	BNC Series Connector
BFS	D	BNC Series Connector

*Note: Most common connector dust caps shown.
Consult Sales Department for others types of dust caps.*

Extended Boots



Cable Option - E The Extended Boot protects the cable from kinking at the cable-to-connector termination. This method uses layers of different lengths of shrink tubing. This will distribute the force applied to the cable-to-connector termination over a 3-5 inch (7-13 cm) length of cable, depending on cable diameter. This method of additional strain relief is available on all flexible cable assemblies manufactured by Smiths Interconnect.

Typical Applications:

- Production and Lab Testing
- Environmental Testing

Typical Properties	
Boot Material	Includes several types of Polyolefin shrink tubing**
Temperature Rating (°C)	-55 to +110
Tensile Strength	2200 PSI
Heat Aging	168 HRS @ 175°C = 175% Elongation
Heat Shock	4 HRS @ 250°C = No Dripping or Cracking
Low Temperature. Flexibility	4 HRS @ -55°C = No Cracking
Flammability	Self Extinguishing
Corrosive Effect	Non-Corrosive
Solvent Resistance	Tensile Strength = >1500 PSI
Water Absorption	0.10%
Fungus Resistance	Non-Nutrient

**Meets the following specifications: MIL-I-23053/5 & /4; AMS-3636; AMS-3637; UL; CSA

Extended Boots (Optional)					
Cable Code	Option Code	Description	Length (Inches)		Bend Radius
			Boot A (Inner)	Boot B (Outer)	
100	E	Shrink Tube Extended Boot	2.5"	2.5"	0.5"
125	E	Shrink Tube Extended Boot	2.5"	2.5"	0.6"
160	E	Shrink Tube Extended Boot	2.5"	4.0"	0.8"
200	E	Shrink Tube Extended Boot	2.5"	4.0"	1.0"
290	E	Shrink Tube Extended Boot	4.0"	6.0"	1.5"
335	E	Shrink Tube Extended Boot	4.0"	6.0"	2.0"

Properties information is typical data only and should not be used for specification requirements. Consult Sales Department for others types of booting.

Cable Assembly Options

Option - ±2.8PS

Cable Option - ±2.8PS The electrical length of coaxial assemblies are often required to be an exact length. The electrical length is determined by the electrical properties of the cable and its mechanical length. Smiths Interconnect offers phase matching for Lab-Flex and other types of cable. There are several types of phase matching and tolerances, offered by Smiths Interconnect. The most common are listed below.

Typical Applications:

- Production and Lab Testing
- Environmental Testing
- Phase-array

- Group* - Phase matched in sets - All of the cable assemblies are matched to each other.
- Absolute** - Phase matched to an electrical length. As with a mechanical standard, this electrical length measured in degrees or time is determined by the customer or provided upon delivery by Smiths Interconnect.
- Pairs** - Phase matched in pairs - Selected from large groups of phase matched assemblies.
- Standard** - Phase matched to a standard - All of the cables are matched to a standard. This standard may have been established from a previous lot or provided by the customer.
- Offset** - Phased offset matching - One or more assemblies are provided with defined phase offset as compared to other assemblies.

* Standard Phase Matching

** Custom Phase Matching, please consult sales department for more details.

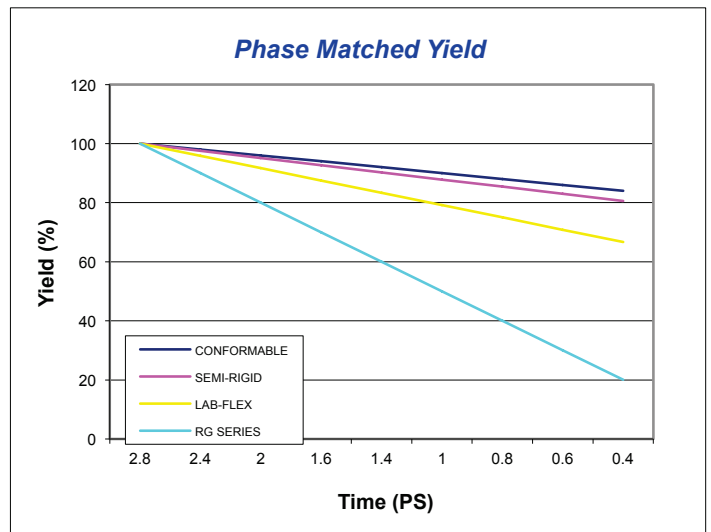
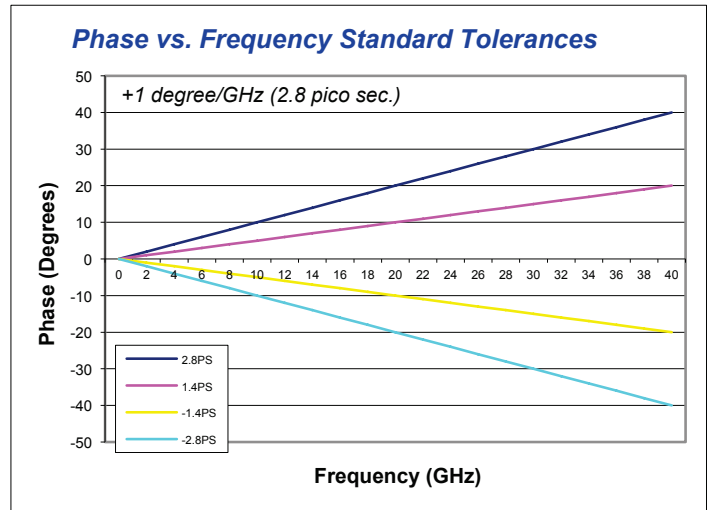

Phase Matching (Optional)			
Cable Code	Option Code	Description	Other
ALL	+/-2.8PS	Phase matched in sets (Relative)	With Electrical Test Data Sheets

Consult Sales Department for others types of Phase Matching.



Cable Option - RoHS Smiths Interconnect has been RoHS (European Directive for Reduction of Hazardous Substances) compliant since April 2005. RoHS compliance requires restriction of the use of Lead (Pb), Mercury (Hg), Cadmium (Cd), Hexavalent Chromium (Cr-VI), Polybrominated Biphenyls (PBB) and Polybrominated Diphenylethers (PBDE) per European Union Directive 2011/65/EU. As the RoHS compliance mandate went into effect in July 2006, Smiths Interconnect would like to confirm that RoHS compliant parts are available across the entire product portfolio.

Smiths Interconnect' RoHS compliant products allow for both tin/lead and lead free solder attachment methods. Where solder is required for assembly of final product, RoHS compliant solders will be used. Products are qualified RoHS compliant in accordance with IPC and JEDEC industry standards. Qualification tests have been performed in accordance with our ISO 9001 certification. This certification signifies that parts meet an internally acceptable set of quality standards. All products that ship as RoHS compliant will be labeled as such on the packaging.



Cable Length Definition and Tolerances

Cable Length Definition

The cable length is defined by the length as measured between the following:

Straight Connectors - From reference plane per M39012. If the connector is not covered in this Mil-Spec, the reference plane is per the connector manufacturer.

Right Angle Connectors - From center line of the inner contact of connector.

Bulkhead - From inside mounting flange of connector.

Cable Length Tolerance (Standard)

Standard Length (inches)			Finished Length Tolerance (inches)
6.0	to	11.9	+0.25, -0.0
12.0	to	23.9	+0.5, -0.0
24.0	to	119.9	+1.0, -0.0
120.0	to	167.9	+2.0, -0.0
168.0	to	215.9	+2.5, -0.0
216.0	to	299.9	+3.0, -0.0
300.0	to	599.9	+6.0, -0.0
600.0	to	UP	+10.0, -0.0

Tighter cable length tolerance can be provided at additional cost.

Tightest tolerance available:

Semi-Rigid/Conformable/BJ under 24 inches: ± 0.030

Flexible under 24 inches: ± 0.075

Note: A tightly controlled length does not assure that the phase will also be controlled (see Phase Matching Option).

Application Notes

Cable Pre-Formed Right Angle

SMA Right Angles

Using either Semi-Rigid or Conformable® cable, Smiths Interconnect can pre-bend the cable to form a right angle prior to soldering a low profile SMA plug onto the cable. The cable must be formed before the connector is soldered on in order to prevent any weakening or damage to the solder joint. The electrical performance of the pre-form is better than a swept or cubed right angle connector, and in most cases, is more cost effective.

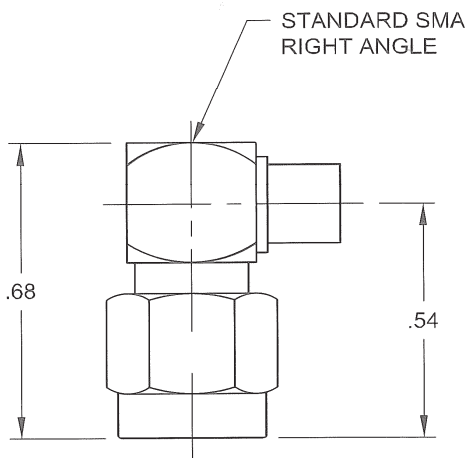

*Standard right angle connector (SMR)
DC to 12.4 GHz - VSWR 1.35 Typical*

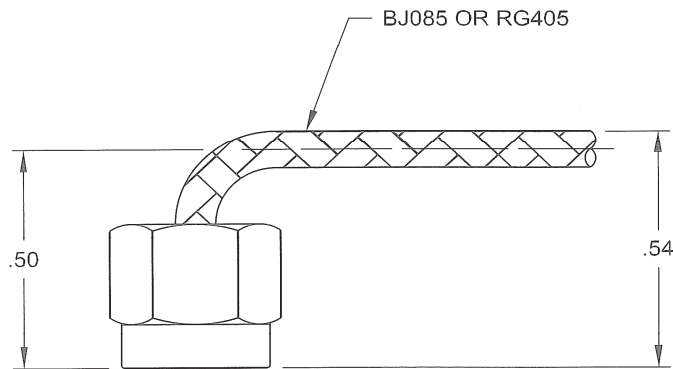

*SMSR for .085 cable
DC to 18.0 GHz - VSWR 1.30 Typical*

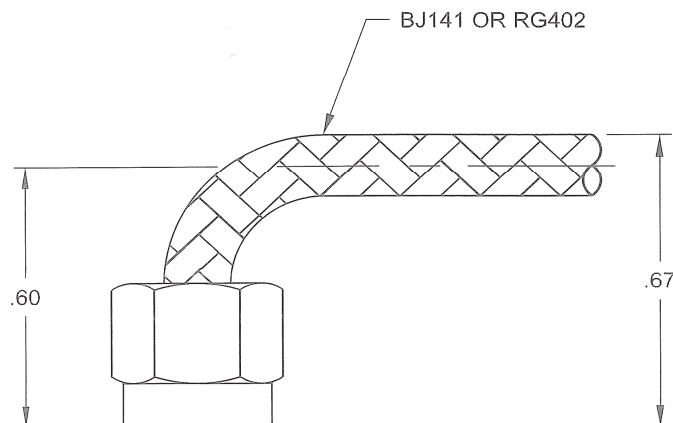

*SMSR for .141 cable
DC to 18.0 GHz - VSWR 1.23 Typical*

Conformable® is a registered trademark of Belden

Smiths Interconnect offers a wide range of connectors. Listed below are some of the most commonly used connectors with their product codes and part numbers for ordering. If you can not find the connector type you need, please consult the sales department.

Series	Gender		Type	Max Freq.	Code
PRECISION HIGH FREQUENCY					
2.4 mm	Plug	(Male)	Straight	50 GHz	MMS
2.4 mm	Bulkhead	(Female)	Straight	50 GHz	MFBS
2.4 mm	Jack	(Female)	Straight	50 GHz	MFS
2.4 mm	Plug	(Male)	Right angle	40 GHz	MMR
GPPO (SMPM)	Bulkhead	(Female)	Straight	50 GHz	SMPMFBS
GPPO (SMPM)	Jack	(Female)	Straight	50 GHz	SMPMFS
GPPO (SMPM)	Jack	(Female)	Right angle	50 GHz	SMPMFR
2.9 mm	Plug	(Male)	Straight	40 GHz	KMS
2.9 mm	Plug	(Male)	Right angle	40 GHz	KMR
2.9 mm	Bulkhead	(Female)	Straight	40 GHz	KFBS
2.9 mm	Jack	(Female)	Straight	40 GHz	KFS
GPO™ (SMP)	Plug	(Male)	Straight	40 GHz	SMPMS
GPO™ (SMP)	Bulkhead	(Female)	Straight	40 GHz	SMPFBS
GPO™ (SMP)	Jack	(Female)	Straight	40 GHz	SMPFBS
GPO™ (SMP)	Jack	(Female)	Flange	40 GHz	SMPFF
GPO™ (SMP)	Jack	(Female)	Right angle	40 GHz	SMPFR
3.5 mm	Plug	(Male)	Straight	35 GHz	3MS
3.5 mm	Bulkhead	(Female)	Straight	35 GHz	3FBS
3.5 mm	Jack	(Female)	Straight	35 GHz	3FS
STANDARD					
7 mm (APC7)	N/A	N/A	Straight	18 GHz	A7
SMA	Plug	(Male)	Straight	18 GHz	SMS
SMA	Plug	(Male)	Right angle	18 GHz	SMR
SMA	Bulkhead	(Female)	Straight	18 GHz	SFBS
SMA	Jack	(Female)	Straight	18 GHz	SFS
TNC	Plug	(Male)	Straight	18 GHz	TMS
TNC	Plug	(Male)	Right angle	18 GHz	TMR
TNC	Bulkhead	(Female)	Straight	18 GHz	TFBS
TNC	Jack	(Female)	Straight	18 GHz	TFS
TYPE N	Plug	(Male)	Straight	18 GHz	NMS
TYPE N	Plug	(Male)	Right angle	18 GHz	NMR
TYPE N	Bulkhead	(Female)	Straight	18 GHz	NFBS
TYPE N	Jack	(Female)	Straight	18 GHz	NFS
TYPE N	Jack	(Female)	Flange	18 GHz	NFFS
BNC	Plug	(Male)	Straight	4 GHz	BMS
BNC	Plug	(Male)	Right angle	4 GHz	BMR
BNC	Bulkhead	(Female)	Straight	4 GHz	BFBS
BNC	Jack	(Female)	Straight	4 GHz	BFS
PKZ	Plug	(Male)	Straight	32 GHz	PKZMS
PKZ	Bulkhead	(Female)	Straight	32 GHz	PKZFBS
PKZ	Jack	(Female)	Straight	32 GHz	PKZFS

VSWR 1.45 max DC to Max Frequency.

Gender of the connector is determined by center pin.

Application Notes

Connector Product Codes

Series	Gender	Type	Max Freq.	Code
SUB-MINIATURES				
SSMA	Plug (Male)	Straight	34 GHz	SSMS
SSMA	Jack (Female)	Straight	34 GHz	SSFS
SSMA	Plug (Male)	Right Angle	34 GHz	SSMR
MCX	Plug (Male)	Straight	6 GHz	MCXMS
MCX	Plug (Male)	Right Angle	6 GHz	MCXMR
MCX	Bulkhead (Female)	Straight	6 GHz	MCXFBS
MCX	Jack (Female)	Straight	6 GHz	MCXFS
MMCX	Plug (Male)	Straight	6 GHz	MMCXMS
MMCX	Plug (Male)	Right Angle	6 GHz	MMCXMR
MMCX	Bulkhead (Female)	Straight	6 GHz	MMCXFBS
MMCX	Jack	Straight	6 GHz	MMCXFS
SMC	Plug (Male)	Straight	10 GHz	SMCMS
SMC	Plug (Male)	Right Angle	10 GHz	SMCMR
SMC	Jack (Female)	Right Angle	10 GHz	SMCFR
SMC	Jack (Female)	Straight	10 GHz	SMCFS
SMB	Plug (Male)	Straight	4 GHz	SMBMS
SMB	Plug (Male)	Right Angle	4 GHz	SMBMR
SMB	Jack (Female)	Straight	4 GHz	SMBFS
SMB	Jack (Female)	Right Angle	4 GHz	SMBFR
OTHERS				
7/16 DIN	Plug (Male)	Straight	7.5 GHz	7/16MS
7/16 DIN	Plug (Male)	Right Angle	7.5 GHz	7/16MR
7/16 DIN	Bulkhead (Female)	Straight	7.5 GHz	7/16FBS
7/16 DIN	Jack (Female)	Straight	7.5 GHz	7/16FS
OSSP (BMMA)	Plug (Male)	Straight	28 GHz	OSSPMS
OSSP (BMMA)	Bulkhead (Female)	Straight	28 GHz	OSSPFBS
OSSP (BMMA)	Jack (Female)	Straight	28 GHz	OSSPFS
OSP (BMA)	Plug (Male)	Straight	22 GHz	BMAMS
OSP (BMA)	Jack (Female)	Straight	22 GHz	BMAFS
OSP (BMA)	Bulkhead (Female)	Straight	22 GHz	BMAFBS
SC	Plug (Male)	Straight	10 GHz	SCMS
SC	Bulkhead (Female)	Straight	10 GHz	SCFBS

VSWR 1.45 max DC to Max Frequency.

Gender of the connector is determined by center pin.

Material and Plating

Standard material for high performance connectors is stainless steel, passivated. Gold plated stainless steel is also available in most cases. Many low frequency or low cost connectors are available in brass with gold, nickel or tri-metal plating.

Passive Intermodulation Concerns

To reduce problems with intermodulation distortion, Smiths Interconnect offers connectors with silver or tri-metal plating (no nickel) on brass bodies. They can be used with cables that have silver plated copper center and outer conductors.

Interseries Mating of Precision Connectors

The five connectors listed here will inter-mate since they all have 0.036 inch diameter mating contacts and a common coupling nut size. Mechanical properties of these five connectors are shown below:

Mechanical Properties of 0.036 Diameter Center Conductor Connectors

Connector	Center Diameter inches (mm)	Center Length inches (mm)	Dielectric	Inner Diameter of Connector Body inches (mm)
SMA	0.036 (0.91)	0.100 (25.4)	PTFE (Teflon)	0.161 (4.1)
3.5mm	0.036 (0.91)	0.065 (1.65)	Air	0.138 (3.5)
2.9mm (K)	0.036 (0.91)	0.065 (1.65)	Air	0.115 (2.9)
K-Compatible (used on K-Jumper)	0.036 (0.91)	0.065 (1.65)	PTFE (Teflon)	0.138 (3.5)
SMA Point & Face (used on BJ141 cable)	0.036 (0.91)	0.065 (1.65)	PTFE (Teflon)	0.138 (3.5)

The differences between the 5 connectors are the length of the mating contact, the dielectric material, and the inside diameter of the connector body. The standard SMA plug has a mating contact up to 0.100 inches long, which can engage the female contact before the connector bodies align the contacts and damage the female contact.

The K-Compatible and the SMA Point and Face both use a mating contact length of 0.065 inches that prevents damage to the female contact.

Electrical Properties of 0.036 Diameter Center Conductor Connectors

Connector Mating	Typical Match in dB (Return Loss)	Electrical Mating Comments
SMA to SMA	20-25 dB @ 18 GHz	Fair
SMA to 3.5mm	22-27 dB @ 18 GHz	Good
SMA to 2.9mm	24-29 dB @ 18 GHz	Excellent
SMA to K-Jumper	22-27 dB @ 18 GHz	Good
SMA to SMS-BJ141	22-25 dB @ 18 GHz	Fair
3.5mm to 3.5mm	20-25 dB @ 18 GHz	Fair
3.5mm to 2.9mm	20-24 dB @ 18 GHz	Fair
3.5mm to K-Jumper	20-24 dB @ 18 GHz	Fair
3.5mm to SMS-BJ141	19-23 dB @ 18 GHz	Fair
2.9mm to 2.9mm	21-24 dB @ 18 GHz	Good
2.9mm to K-Jumper	20-24 dB @ 18 GHz	Fair
2.9mm to SMS-BJ141	19-23 dB @ 18 GHz	Fair

Point and Face Design

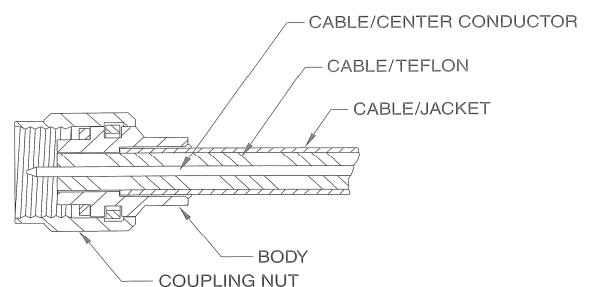

Both the K-Jumper and SMS-BJ141 use the center conductor of the cable as the male contact. The cable center conductor has a 0.036 inch diameter; the conductor is cut and pointed to a length of 0.065 inches to form the connector contact. The cable jacket stops midway through the connector body and is soldered in place. The cable used in the K-Jumper and SMS-BJ141 assemblies have a stable dielectric, which resists dielectric growth under temperature extremes.

The K-Compatible connectors used in K-Jumper assemblies are designed to mate with 2.9mm and 3.5mm connectors. The frequency limit of the K-Jumper is the cutoff frequency of the cable, 35.5 GHz.

Application Notes

Care and Handling

Connector Interfaces:

Interface Cleanliness - Clean Interfaces prolong connector life and produce more accurate, repeatable measurements. The use of connector end-caps to protect the cables and adapters when not in use is recommended.

Interface Cleaning Procedure:

- 1. Solvents:** Connector Insulators, support beads, and seals are susceptible to solvent damage. Solvents can produce permanent physical and electrical damage. Isopropyl alcohol is recommended for cleaning interfaces. It should be noted that connector interfaces should not be immersed in solvents of any kind because solvents can become trapped within the connectorized assembly. Trapped fluids can cause SWR, Phase, and Insertion Loss problems.
- 2. Applicators:** Fibrous or Abrasive applicators can contaminate and even damage interface surfaces. Clean, lint free swabs should be used. They need to be sharp and hard enough to remove dirt and debris without damaging surfaces and/or dislodging center pins.
- 3. Method:** Dip a clean, lint free swab in clean isopropyl alcohol. Press excess alcohol out of swab on a clean, lint free towel. Wipe the interface components as required to clean the interface. Blow-dry the interface with clean compressed air. Re-inspect the connector to verify that the interface is clean and ready for additional inspection procedures and interface gauging prior to use.

Interface Gauging:

Incorrect center pin depths can produce inaccurate measurements and in the case of protruding center pins can damage test devices, adapters, and test ports. Frequent interface gauging can detect problems before they ruin mating devices (see Table I for connector interface pin depths).

Table I: Connector Interface Pin Depths

Connector Interface	Reference Plane (in)	Specification
7mm	1	IEEE STD 287
N Male	0.210/-0.230	MIL-STD-348
N Female	0.903381643	MIL-STD-348
3.5mm	0/-0.003	IEEE STD 287
2.92mm	0/-0.003	IEEE STD 287
2.4mm	0/-0.002	IEEE STD 287
1.85mm	0/-0.002	IEEE STD 287
SMA	0/-0.010	MIL-STD-348
TNC / BNC	0.913043478	MIL-STD-348
TNC / BNC	0.902912621	MIL-STD-348
7/16 Male	0.830703013	IEC 169-4
7/16 Female	0.855214724	IEC 169-4

Typical Phase Stability versus Temperature

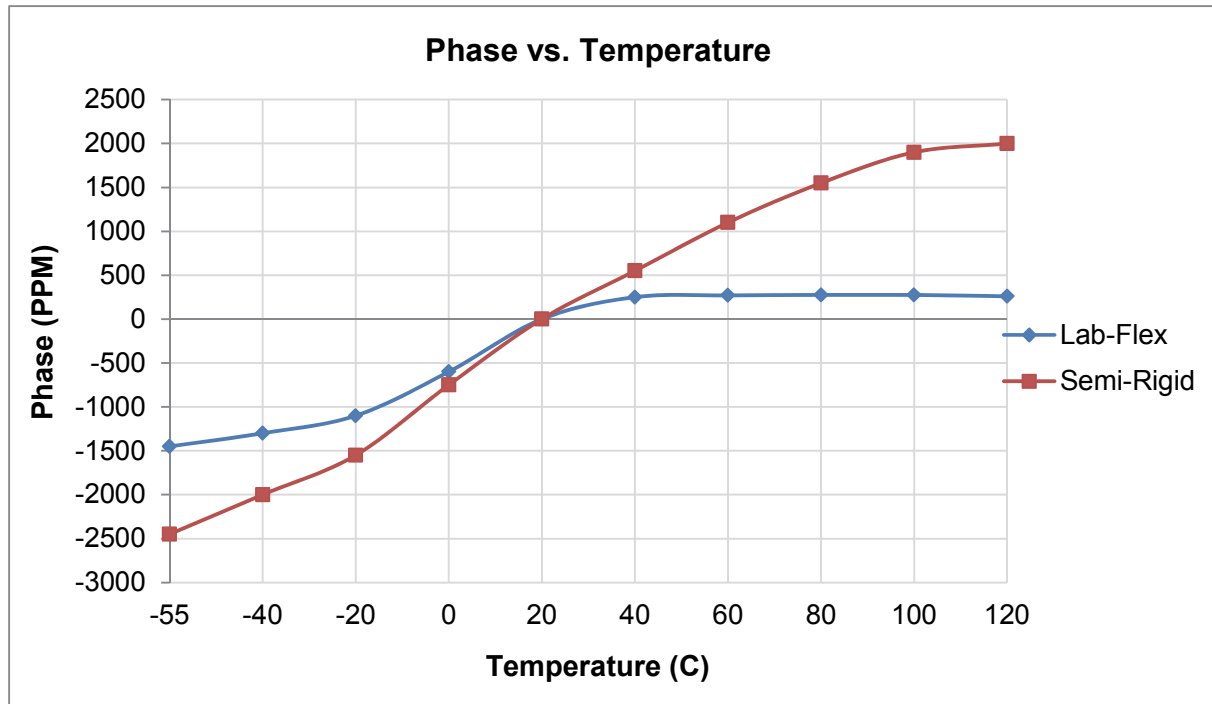

PPM Calculations

The electrical phase length of any coaxial cable will change over temperature.

To calculate the expected phase change of a Lab-Flex cable for any given temperature ranges use the following method.

Example: Calculate the phase change of a 120 inch long Lab Flex assembly at -30°C at 10 GHz.
 EI @ 10 GHz = 46,585.90
 PPM @ -30 = -1180
 $(EI \times PPM) / 1,000,000 = -54.97136$ degrees of change @ -30 Celsius

Materials Abbreviations

CONDUCTORS & BRAID MATERIALS		
AL	Aluminum	per MIL-C-17
BC	Bare Copper	per MIL-C-17
BeCu	Beryllium-Copper Alloy 172	per MIL-C-17
BCCAI	Bare Copper Clad Aluminum	per MIL-C-17
CCS	Bare Copper Clad Steel	per MIL-C-17
GS	Galvanized Steel	per MIL-C-17
HR	High Resistance Wire	per MIL-C-17
MW	Magnet Wire	per MIL-C-17
NC	Nickel Covered Copper	per MIL-C-17
SA	Silver Covered Alloy	per MIL-C-17
SC	Silver Covered Copper	per MIL-C-17
SCBeCu	Silver Covered Beryllium Copper	per MIL-C-17
SCCadBr	Silver Covered Cadmium Bronze	per MIL-C-17
SCCA1	Silver Covered Copper Clad Aluminum	per MIL-C-17
SCCS	Silver Covered Copper Clad Steel	per MIL-C-17
SNCCS	Silver Covered Nickel Covered Copper Clad Steel	per MIL-C-17
SCS	Silver Covered Copper Strip	per MIL-C-17
TC	Tinned Copper	per MIL-C-17
TCCS	Tinned Copper Clad Steel	per MIL-C-17
DIELECTRIC MATERIALS		
PE	Solid Low Density Polyethylene	per MIL-C-17
PTFE	Solid Polytetrafluoroethylene	per MIL-C-17
LDTFE	Low Density PTFE	per MIL-C-17
Foam PE	Gas Injected Foam PE	per MIL-C-17
FEP	Solid Fluorinated Ethylene Propylene	per MIL-C-17
CPT	Conductive PTFE	per MIL-C-17
CPE	Conductive Polyethylene	Type A-5 per MIL-C-170
Rubber	per MIL-C-17 (obsolete)	per MIL-C-17
MGO	Magnesium Oxide	per MIL-C-17
INTERLAYER MATERIALS		
PE	Solid Polyethylene	per MIL-C-17
PTFE	Solid Polytetrafluoroethylene	per MIL-C-17
MY	Polyester	per MIL-C-17
KP	Polyimide	per MIL-C-17
ALMY	Aluminum-Polyester Laminate	per MIL-C-17
ALKP	Aluminum-Polyimide Laminate	per MIL-C-17
CPC	Copper-Polyester-Copper Laminate	per MIL-C-17
JACKET MATERIALS		
E-CTFE	Ethylene Chlorotrifluoroethylene	Type XI per MIL-C-17
ETFE	Ethylene Tetrafluoroethylene Copolymer	Type X per MIL-C-17
FEP	Fluorinated Ethylene Propylene	Type IX per MIL-C-17
FG Braid	Fiberglass; Impregnated	Type V per MIL-C-17
PE	Clear Polyethylene	Type III per MIL-C-17
LS/LT	Low Smoke/Low Toxicity	(XLPE)
PE	Polyethylene, black HMW	Type IIIA per MIL-C-17
PFA	Perfluoroalkoxy	Type-XIII per MIL-C-17
PTFE	Polytetrafluoroethylene	Type VIIA per MIL-C-17
PUR	Polyurethane, black	Type XII per MIL-C-17
PVC-I	Polyvinyl Chloride, black (contaminating)	Type I per MIL-C-17
PVC-II	Polyvinyl Chloride, grey (non-contaminating)	Type II per MIL-C-17
PVC-IIA	Polyvinyl Chloride, black (non-contaminating)	Type IIA per MIL-C-17
Rubber	Obsolete	per MIL-C-17
SIL/DAC	Dacron Braid over Silicone Rubber	Type VI per MIL-C-17
TPE	Thermo Plastic Elastomer	
XLPE	Cross linked Polyolefin	Type XIV per MIL-C-17

Global Support

Americas

- Kansas City, KS
+1 913 342 5544
info.us@smithsinterconnect.com
- Kirkland, QC, Canada
+1 514 842 5179
info.us@smithsinterconnect.com
- Milpitas, CA
+1 408 957 9607 x 1125
info.us@smithsinterconnect.com
- Salisbury, MD
+1 800 780 2169
info.us@smithsinterconnect.com
- Tampa, FL
+1 813 901 7200
info.tampa@smithsinterconnectinc.com

Europe

- Deggendorf, Germany
+49 991 250 120
info.de@smithsinterconnect.com
- Dundee, UK
+44 1382 427 200
info.dundee@smithsinterconnect.com
- Genoa, Italy
+39 0 10 60361
info.it@smithsinterconnect.com
- Rouen, France
+33 2 32 96 91 76
info.fr@smithsinterconnect.com

Asia

- Bangalore, India
+91 080 4241 0529
info.in@smithsinterconnect.com
- Mianyang, China
+86 816 231 5566
HSICSR@hf-smiths.com
- Shanghai, China
+86 21 2283 8008
info.asia@smithsinterconnect.com
- Suzhou, China
+86 512 6273 1188
info.asia@smithsinterconnect.com
- Singapore
+65 6846 1655
info.asia@smithsinterconnect.com

smithsinterconnect.com



Copyright © 2020 Smiths Interconnect | All right reserved | Version 1.0

Disclaimer

All of the information included in this catalogue is believed to be accurate. It is recommended, however, that users should independently evaluate the suitability of each product for their intended application and be sure that each product is properly installed, used and maintained to achieve desired results.

Smiths Interconnect makes no warranties as to the accuracy or completeness of the information, and disclaims any liability regarding its use.

Smiths Interconnect reserves the right to modify design and specifications, in order to improve quality, keep pace with technological development or meet specific production requirements.

No reproduction or use without express permission of editorial and pictorial content, in any manner.