

TN15E+ Transmission Family

The TN15E+ is the latest generation in a family of cross drive transmissions with integral steering system, suitable for tracked armoured personnel carriers and armoured fighting vehicles up to 235bhp.

The introduction of dieselisation and new materials throughout the transmission has helped in increasing the original TN15P from 195bhp up to 235bhp, with vehicle weight increased from 9 tonnes to 13 tonnes.

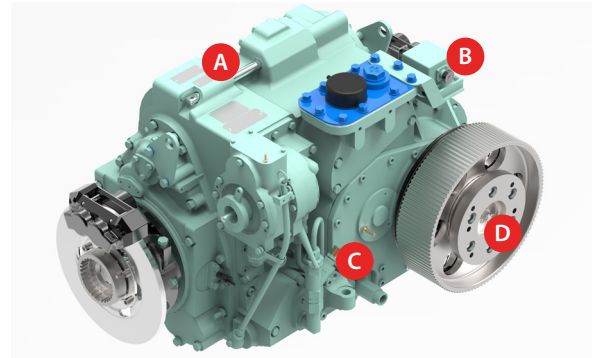

A – Forward/reverse mechanism

B – Data port

C – Oil strainer and test point

D – Centrifugal clutch

Key features	
Rating	235bhp at 2400rpm
Configuration	Offset cross drive manual or fully automatic
Speeds	7 forward, 7 reverse
Arrangement	<ul style="list-style-type: none"> • Three speed compound epicyclic gear set with low and high ranges. A further multiplate clutch is employed for seventh gear. Remote mounted or close coupled • Manual or automatic gear selection, automatic achieved by replacing the mechanical selector with electro hydraulic valve block which sits in the same space envelope
Overall ratio speed	19.4

Principle dimensions	
Length	627mm
Height	573mm
Width	891mm
Dry weight	425kg

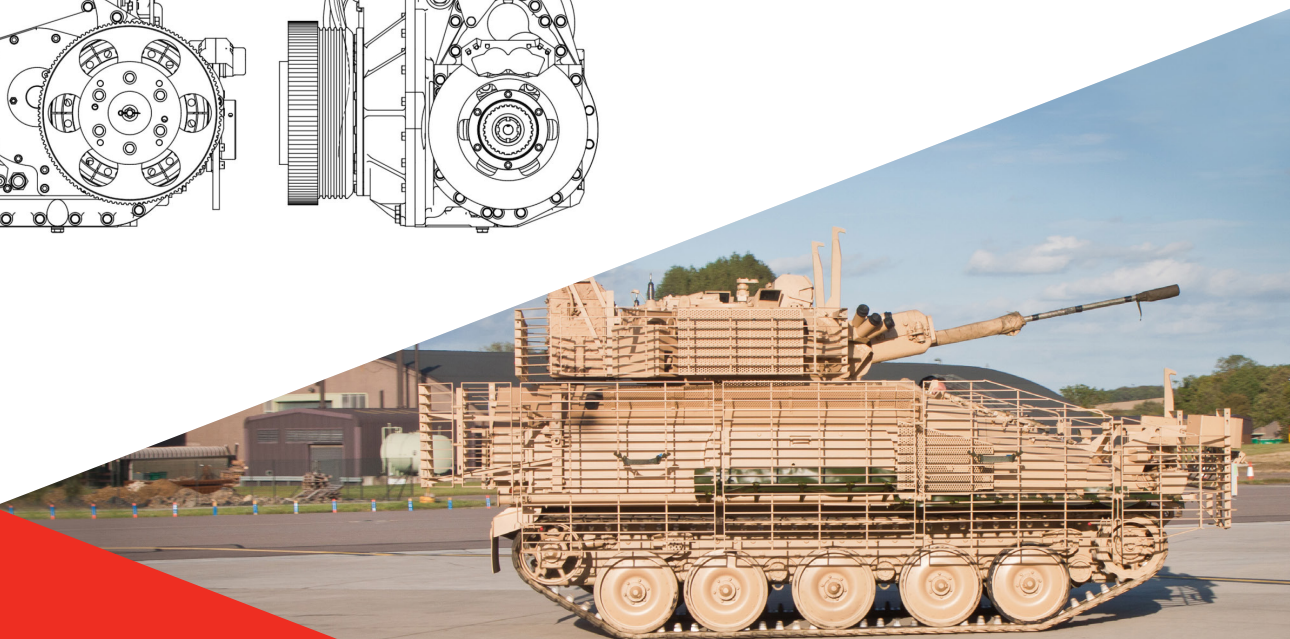
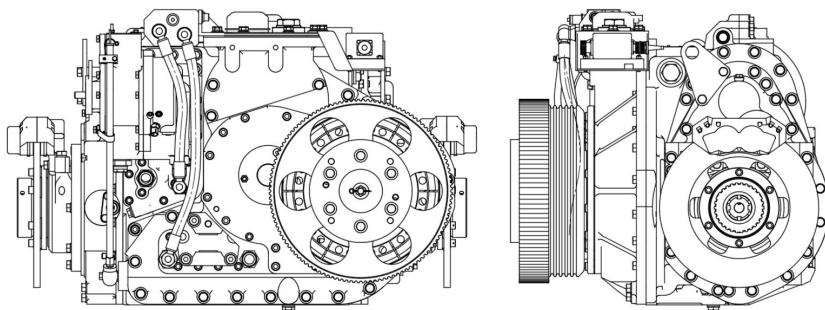

Rating

- Maximum input torque 800Nm at 1800rpm
- Maximum input power 235bhp at 2400rpm
- Typical maximum vehicle weight 13 tonnes

Steering

- Merritt-Brown regenerative system employing single disc brakes

Gearbox	Drive ratio (straight)	Steering (typical metres)	Min. radii (feet)
1 (Lx1)	16.10	1.71	5.6
2 (Lx2)	7.18	3.84	12.9
3 (Lx3)	5.15	5.33	17.5
4 (Hx1)	3.10	8.9	29.2
5 (Hx2)	1.72	16.06	52.7
6 (Hx3)	1.31	21.28	69.8
7 (Hx7)	0.83	33.22	109

Lubrication system

- Oil type OMD 90 transmission oil circulated by an integral mounted gear pump driven from the engine input. Pressure regulated by a pre-set integral mounted pressure relief valve
- Full flow filtration system on all E and E+ transmissions, with the main transmission filter mounted on the transmission or vehicle mounted if required

Brakes

- Main brakes and handbrake system are vehicle mounted
- David Brown Santasalo can assist in the upgrade of existing brake systems or help in designing a complete new system

Control system

- Electro hydraulic fully automatic, electro hydraulic semi-automatic and mechanical hydraulic controllers
- Both the mechanical and the automatic selectors used fit in the same space envelope on the transmission
- Operation of the fully automatic system is by a simple gear selector and an electronic controller – both can be configured to suit individual customer requirements
- David Brown Santasalo can supply harnesses, connections and assist in vehicle integration if required

Input

- Centrifugal clutch – requires larger capacity clutch if vehicle weight approaches 13 tonnes

Auxiliary drive (PTO)

- Belt from centrifugal clutch, if required

Mounting

- Trunnion mounted at the outputs with a reaction mount for remote location next to the input

Upgrades

- Upgrades are available – please contact David Brown Santasalo for further information

David Brown Santasalo

Park Works, Park Road
Lockwood Huddersfield HD4 5DD, UK
Tel: +44 (0)1484 465 500

The information contained in this catalogue has been obtained through sources deemed reliable but cannot be guaranteed as to its accuracy. Any information of special interest should be obtained through independent verification and consulted with a David Brown Santasalo representative.

In the interest of continuous development, David Brown Santasalo reserves the right to alter designs and specifications without prior notice.

David Brown Santasalo is certified to ISO 9001:2008, 14001:2015 and 45001:2018. Your David Brown Santasalo representative should be consulted prior to product selection and use. 3X terms and conditions apply. Contact your local David Brown Santasalo representative for details and to check eligibility.

Europe

Finland: finland@dbsantasalo.com

France: france@dbsantasalo.com

Germany: germany@dbsantasalo.com

Russia: russia@dbsantasalo.com

Sweden: sweden@dbsantasalo.com

Turkey: turkey@dbsantasalo.com

UK: uk@dbsantasalo.com

Americas

Canada: canada@dbsantasalo.com

Chile: chile@dbsantasalo.com

Peru: peru@dbsantasalo.com

USA: usa@dbsantasalo.com

Asia Pacific

Australia: australia@dbsantasalo.com

China: suzhou@dbsantasalo.com

India: india@dbsantasalo.com

Indonesia: indonesia@dbsantasalo.com

Malaysia: malaysia@dbsantasalo.com

Philippines: philippines@dbsantasalo.com

Africa

South Africa: salessa@dbsantasalo.com

www.dbsantasalo.com